

The new Class

ZURCON® Z20 / Z22
New worldclass polyurethane materials

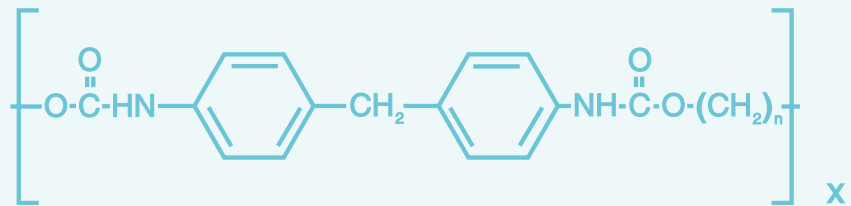

Your Partner for Sealing Technology

Introduction

Polyurethane seals based on old technology materials do not meet the high requirements of tomorrow's fluid power industry in many key areas:

- Leak free performance
- Life
- Life cycle cost
- Temperature range

Trelleborg Sealing Solutions has therefore invested in in-house laboratory and material production facilities to develop tailor made polyurethane materials with exceptional properties to meet the expectations of the fluid power industry.

The first of this new generation of materials are now approved and released by Trelleborg Sealing Solutions:

Zurcon® Z20

Standard material for hydraulic applications.

Zurcon® Z22

Premium material for hydraulic seals applications with a wide operating temperature range.

Zurcon® Z201

Standard material for hydraulic scrapers.

Zurcon® Z221

Premium material for hydraulic scrapers for low and high temperatures.

All Trelleborg Sealing Solutions standard hydraulic seals and scrapers will be offered in the new Zurcon® material Z20/Z201 or in the premium Zurcon® Z22/Z221.

Further Zurcon® materials for alternative application types are under development and will be released as they are approved by Trelleborg Sealing Solutions.

Positioning

For all hydraulics applications with normal operating conditions, the standard polyurethane materials are recommended; Zurcon® Z20 for seals and Zurcon® Z201 for scrapers. For applications where an excellent low temperature behaviour is necessary, the new premium polyurethane Zurcon® Z22 for seals and Zurcon® Z221 for scrapers are recommended for improvements in cold flexibility and compression set. Pricing of seals and scrapers in Zurcon® Z22/Z221 is higher than the standard Zurcon® Z20/Z201.

Extrusion resistance, wear resistance

Trelleborg Sealing Solutions seals (U-cup or L-cup) produced in the new Zurcon® polyurethane materials, have outstanding extrusion and wear resistance. Therefore life, life-cycle cost and leak free performance all meet the high expectations of the end user.

No additional back-up ring is necessary for applications up to 40 Mpa if Trelleborg Sealing Solutions installation recommendations are used.

Fluid compatibility

Zurcon® Z20 and Zurcon® Z22 have been developed for use in mineral oil based hydraulic fluids. They can also be used in synthetic ester fluids within the recommended temperature range. The swell of Zurcon® Z20 in mineral oil is very low (ASTM 3 approx. 6%).

Operating temperature

The new developed Zurcon® polyurethane materials have an extended temperature range compared to old technology polyester (AU) or polyether (EU) based materials. These excellent properties increase the life, extrusion resistance and leakage performance for seals and scrapers.

Figure 1: Operating temperature range for the new Zurcon® materials

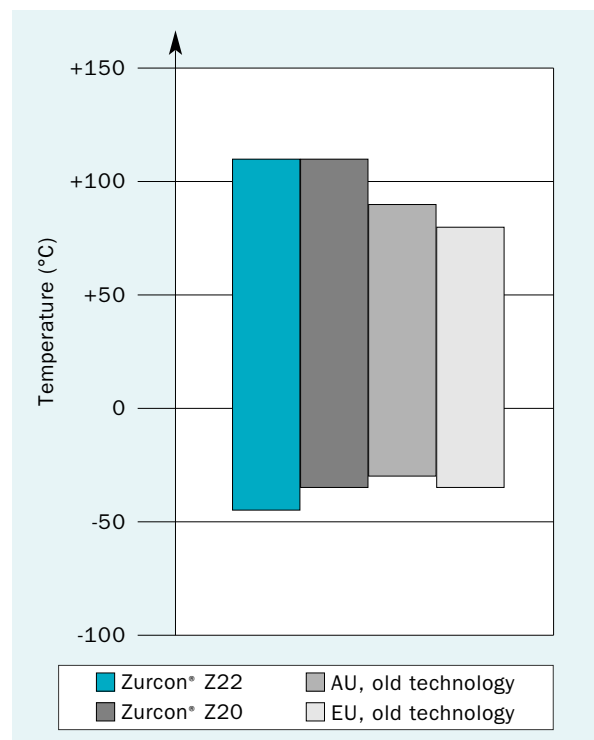

Table 1:

Typical material properties

Material	Units	Z20	Z22	TPU - old technology
Hardness	Shore A	93	93	93
100% modulus	MPa	12	13	10
Ultimate elongation	% (min.)	550	550	450
Tensile strength	MPa	57	55	45
Compression set				
24h / -20°C	%	46	25	65
72h / +70°C	%	23	21	35
72h / +100°C	%	39	36	55
3h / +130°C	%	28	25	35
Rebound resilience	%	41	44	30
TR10-point	°C	-34	-50	-27
Operating Temperature				
Max.	°C	+110	+110	+80
Min.	°C	-35	-45	-30
Colour	-	Turquoise	Dark turquoise	Turquoise

Compression set

Zurcon® Z22 and Zurcon® Z20 materials have been tailor made to have very low compression set values to meet applications under low or high temperature conditions as well as the paint drying process of hydraulic components with water based varnish paint coats.

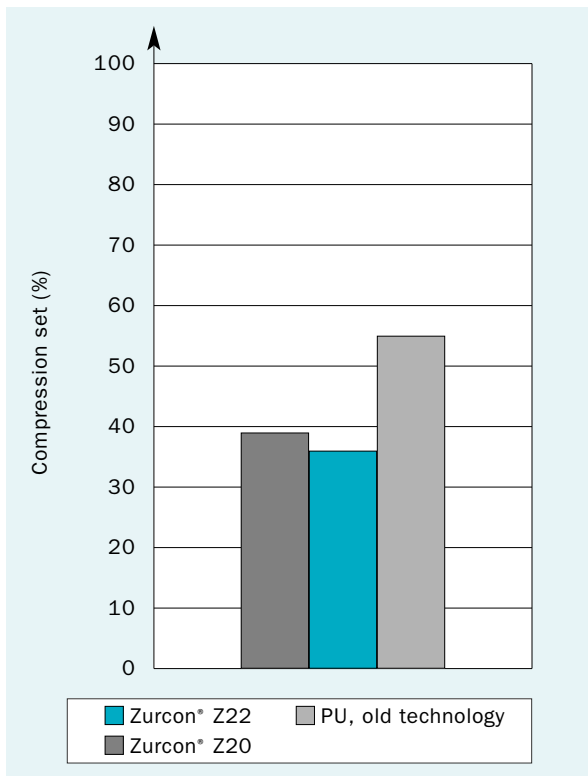
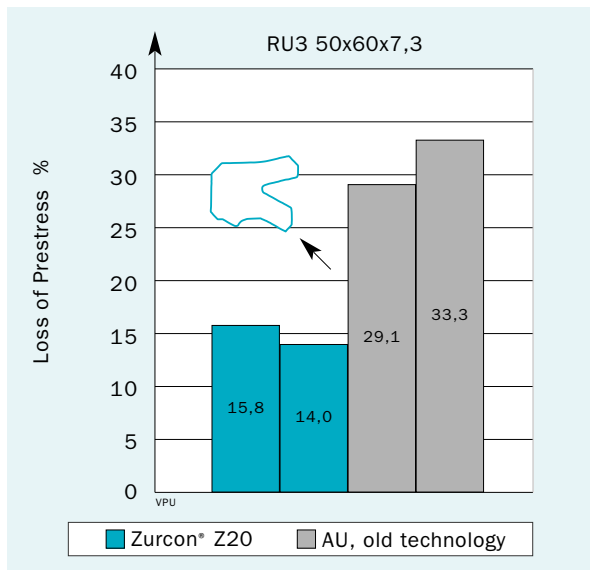

Figure 2: **Compression set 72 h / 100°C**

Figure 3: **Loss of contact stress 30min /130°C**

Short duration high temperature exposure creates severe loss of sealing stress in old technology materials.



Wear and extrusion performance of U-Cups

U-Cup RU2100500, 50 x 60 x 11

Zurcon® Z20 (Figure 4)

versus

PU, old technology (Figure 5)

U-Cup RU3200500, 50 x 65 x 12,5

Zurcon® Z20 (Figure 6)

versus

U-Cup, old technology (Figure 7)

The performance of different U-cups in different materials has been tested under the following test conditions

(Figure 8):

Pressure (cycling)	0-30 MPa	Velocity	0.2 m/s
Cycles	200 000	Stroke	300 mm
Oil temperature	+80°C	Extrusion gap	0.2 mm

Figure 4-8:

Test results



Figure 4: Zurcon® Z20



Figure 6: Zurcon® Z20



Figure 8: rod seal test rig



Figure 5: PU, old technology

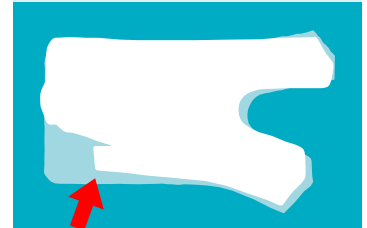

Figure 7: U-Cup, old technology

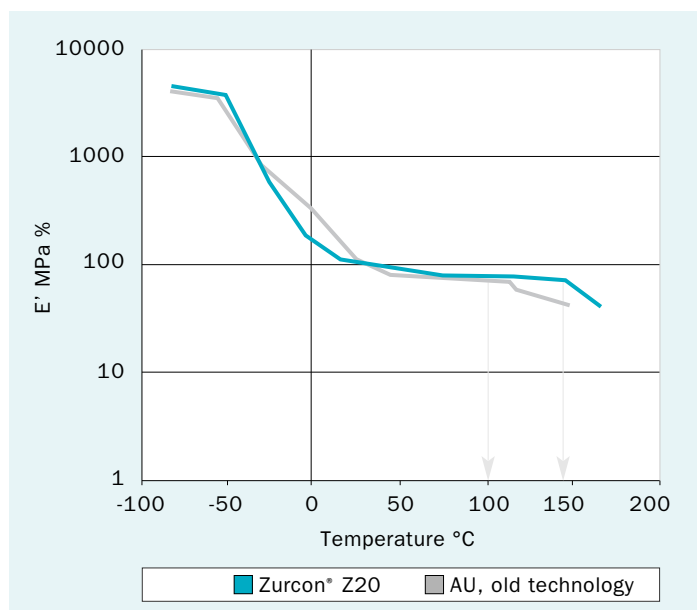

Figure 9: DMA Storage Modulus

Viscoelastic characterisation of materials by a Dynamic Mechanical Analysis (DMA)

DMA curves show the Storage Modulus E in relation with the temperature variation. DMA analysis of Zurcon® Z20 and old technology materials shows the stable elastic modulus of Zurcon® Z20 extending to +145°C and improved flexibility to -30°C.

In the area of +15°C to -30°C a significant improvement of the Zurcon® Z20 behaviour compared to the old technology material can be noticed.

Sealing solution with Zurcon® Z20 seals for hydraulic cylinder

The total sealing solution for a medium duty mobile hydraulic cylinder includes: static seals (Dualseal), piston and rod seals and scraper in Zurcon® Z20/Z201. This is a reliable and cost effective solution, which can meet the industry expectations in terms of leak free performance, life and installed cost.

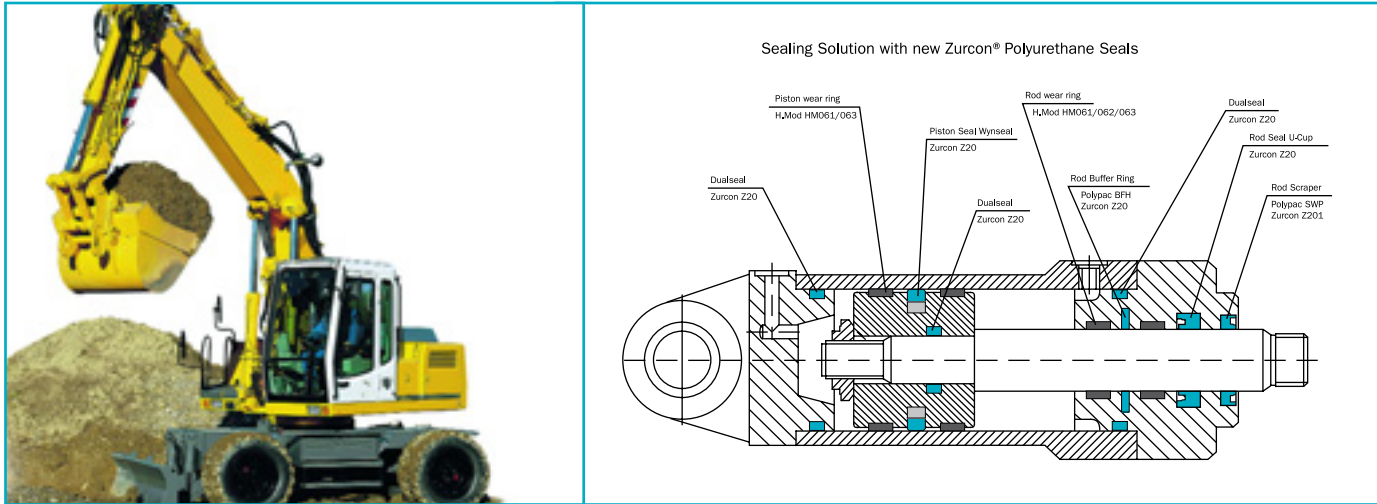

Figure 10

Zurcon® Z20 / Z22 material performance

Zurcon® materials outperform old technology polyester and polyether materials in all critical properties.

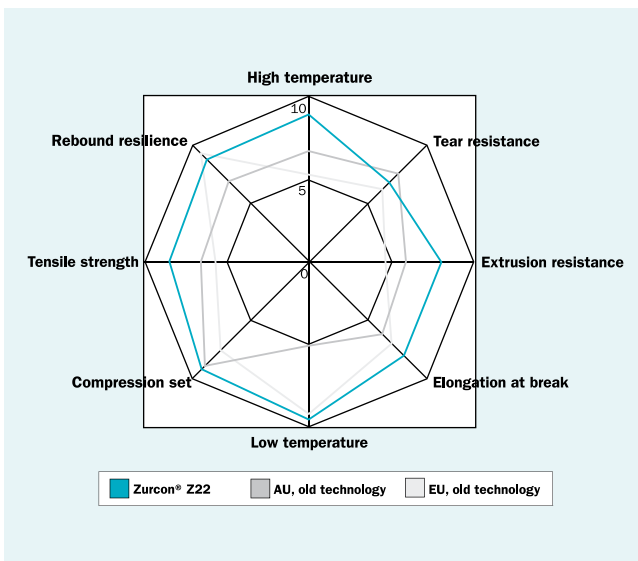

Figure 11

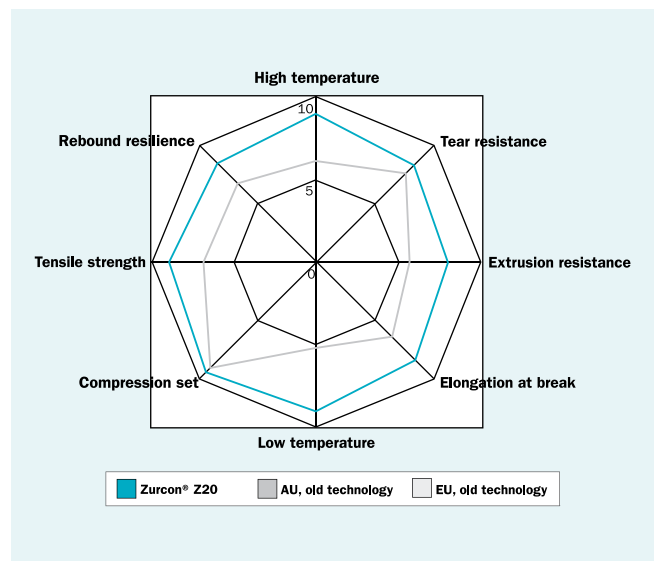

Figure 12

Contact your local marketing company for further information:

Europe

AUSTRIA - Vienna
(ALBANIA, BOSNIA AND HERZEGOVINA,
MACEDONIA, SERBIA AND MONTENEGRO, SLOVENIA)

+43 (0) 1 406 47 33

BELGIUM - Dion-Valmont
(LUXEMBOURG)

+32 (0) 10 22 57 50

BULGARIA - Sofia
(ROMANIA)

+359 (0)2 969 95 99

CROATIA - Zagreb

+385 (0) 1 24 56 387

CZECH REPUBLIC - Rakovnik
(SLOVAKIA)

+420 313 529 111

DENMARK - Hillerød

+45 48 22 80 80

FINLAND - Vantaa
(ESTONIA, LATVIA)

+358 (0) 207 12 13 50

FRANCE - Maisons-Laffitte

+33 (0) 1 30 86 56 00

GERMANY - Stuttgart

+49 (0) 711 7864 0

GREECE

+41 (0) 21 631 41 11

HUNGARY - Budaörs

+36 (06) 23 50 21 21

ITALY - Livorno

+39 0586 22 6111

THE NETHERLANDS - Barendrecht

+31 (0) 10 29 22 111

NORWAY - Oslo

+47 22 64 60 80

POLAND - Warsaw
(LITHUANIA, UKRAINE, BELARUS)

+48 (0) 22 863 30 11

RUSSIA - Moscow

+7 495 982 39 21

SPAIN - Madrid
(PORTUGAL)

+34 (0) 91 71057 30

SWEDEN - Jönköping

+46 (0) 36 34 15 00

SWITZERLAND - Crissier

+41 (0) 21 631 41 11

TURKEY

+41 (0) 21 631 41 11

UNITED KINGDOM - Solihull
(EIRE)

+44 (0) 121 744 1221

AFRICA REGIONAL

+41 (0) 21 631 41 11

MIDDLE EAST REGIONAL

+41 (0) 21 631 41 11

Americas

AMERICAS - REGIONAL

+1 260 749 9631

BRAZIL - São Paulo

+55 11 3372 4500

CANADA - Etobicoke, ON

+1 416 213 9444

MEXICO - Mexico City

+52 55 57 19 50 05

USA, East - Conshohocken, PA

+1 610 828 3209

USA, Great Lakes - Fort Wayne, IN

+1 260 482 4050

USA, Midwest - Lombard, IL

+1 630 268 9915

USA, Mountain - Broomfield, CO

+1 303 469 1357

USA, Northern California - Fresno, CA

+1 559 449 6070

USA, Northwest - Portland, OR

+1 503 595 6565

USA, South - N. Charleston, SC

+1 843 747 7656

USA, Southwest - Houston, TX

+1 713 461 3495

USA, West - Torrance, CA

+1 310 371 1025

Asia Pacific

Telephone

ASIA PACIFIC REGIONAL

+65 6 577 1778

CHINA - Hong Kong

+852 2366 9165

CHINA - Shanghai

+86 (0) 21 6145 1830

INDIA - Bangalore

+91 (0) 80 2245 5157

JAPAN - Tokyo

+81 (0) 3 5633 8008

KOREA - Anyang

+82 (0) 31 386 3283

MALAYSIA - Kuala Lumpur

+60 (0) 3 9059 6388

TAIWAN - Taichung

+886 4 2382 8886

THAILAND - Bangkok

+66 (0) 2732-2861

SINGAPORE

+65 6 577 1778

and all other countries in Asia

www.tss.trelleborg.com



TRELLEBORG
SEALING SOLUTIONS