

Ventseal - Light



**NEW: the reliable
elastomeric venting valve**



Your Partner for Sealing Technology



Your Partner for Sealing Technology

Trelleborg Sealing Solutions is a major international sealing force, uniquely placed to offer dedicated design and development from our market leading product and material portfolio; a one-stop shop providing the best in elastomer, thermoplastic, PTFE and composite technologies for applications in aerospace, industrial, and automotive industries.

With 50-years experience, Trelleborg Sealing Solutions engineers support customers with design, prototyping, production, test and installation using state-of-the-art design tools. An international network of over 70 facilities worldwide includes 30 manufacturing sites, strategically positioned research and development centers, including materials and development laboratories and locations specializing in design and applications.

Developing and formulating materials in-house, we utilize the resource of our material database, including over 2,000 proprietary compounds and a range of unique products.

Trelleborg Sealing Solutions fulfills challenging service requirements, supplying standard parts in volume or a single custom-manufactured component, through our integrated logistical support, which effectively delivers over 40,000 sealing products to customers worldwide.

Facilities are certified to ISO 9001:2000 and ISO/TS 16949:2002. Trelleborg Sealing Solutions is backed by the experiences and resources of one of the world's foremost experts in polymer technology, Trelleborg Group.

ISO 9001:2000

ISO/TS 16949:2002

The information in this brochure is intended to be for general reference purposes only and is not intended to be a specific recommendation for any individual application. The application limits for pressure, temperature, speed and media given are maximum values determined in laboratory conditions. In application, due to the interaction of operating parameters, maximum values may not be achieved. It is vital therefore, that customers satisfy themselves as to the suitability of product and material for each of their individual applications. Any reliance on information is therefore at the user's own risk. In no event will Trelleborg Sealing Solutions be liable for any loss, damage, claim or expense directly or indirectly arising or resulting from the use of any information provided in this brochure. While every effort is made to ensure the accuracy of information contained herewith, Trelleborg Sealing Solutions cannot warrant the accuracy or completeness of information.

To obtain the best recommendation for a specific application, please contact your local Trelleborg Sealing Solutions marketing company.

This edition supersedes all previous brochures.
This brochure or any part of it may not be reproduced without permission.

© All trademarks are the property of Trelleborg Group.
The turquoise color is a registered trademark of Trelleborg Group.
© 2008, Trelleborg Group. All rights reserved.



Contents

General, Fields of Application	2
Function	2
Advantages	2
Installation Recommendations	3
Technical Data	3
Materials	3
Opening Pressure	4
Ordering Example	5



Ventseal-Light

■ Ventseal-Light

General, Fields of Application

Ventseal-Light is designed for the venting of closed receptacles, in which a low pressure build-up causes malfunction. After the venting process, the pressure room shall be safely sealed against influences from outside.

Maintenance-free closed storage batteries need such venting valves to ensure their good function over longer periods of time.

Preferred cases of application are maintenance-free lead gel storage batteries, Ni-Cd batteries, Ni-MH batteries and VLRA batteries.

The requirements on such components are very demanding. If the valves do not close correctly the affected cell will dry out within a short period of time or be destroyed due to the ingress of atmospheric oxygen.

The function of the valve's opening mechanism therefore must be absolutely reliable. If the ultimate opening pressure is exceeded due to a jammed valve, the potential risks range from structure damages within the cell up to its entire destruction.

Due to the constantly rising demands on reliability, longevity and efficiency, present valves have come up against limiting factors. These demands have been considered in the development of the Ventseal-Light. This patented low-pressure valve (European Patent No. 989487087) combines an excellent impermeability with a secure opening and closing behaviour.

Apart from the aforementioned advantages, the Ventseal-Light is also suitable for all cases where the pressure in a closed receptacle must be kept below a certain limit, while at the same time any ingress from the outside has to be sealed off securely. The use of different elastomer materials grants a reliable sealing of various media.

Ventseal-Light is, with regard to function and cost, an optimized version of the well-known Ventseal series of Trelleborg Sealing Solutions.

It combines the characteristics of a seal and a pressure control valve in one single product.

This version allows adjustment to the opening pressure and adaption to the respective application.

Opening pressure ranges from 50 to 400 mbar.

Function

The following installation example demonstrates the function mode:

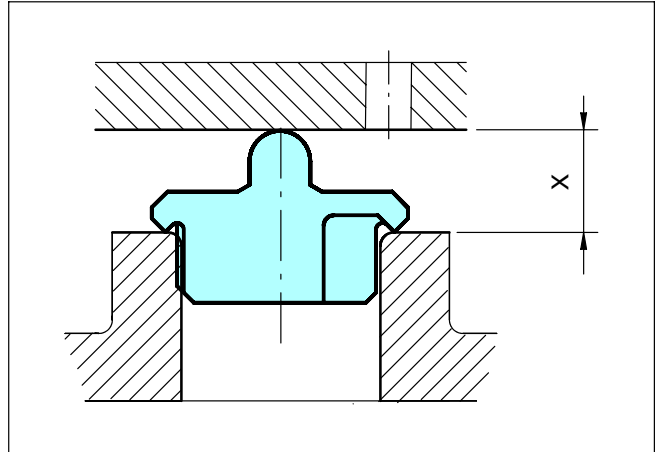

Figure 1 Ventseal-Light installed on a battery muff

In the present case the Ventseal-Light is mounted onto a battery muff. A simple bore is also possible. The sealing face located at the front of this muff (bore) has a certain surface quality. Here, the Ventseal-Light, energized with a cover, seals with its annular sealing edge. The cover is designed with a pre-defined distance X towards the muff. This dimension X allows adjustment to the opening pressure. A steering channel inside the Ventseal-Light allows the overpressure in the receptacle to escape towards the sealing edge where it lifts off the sealing edge at a certain pressure level. After a drop in pressure the sealing lip reseals the pressure room. Ventseal-Light thus reliably fulfils its sealing function. As soon as pressure comes from the outside resp. at low pressure within the battery Ventseal-Light acts as a safe seal.

Advantages

- Ventseal-Light supplies a very good price/performance relation
- Ventseal-Light provides a very good sealing ability. Additional advantage is the possibility of adapting the opening pressure to the respective application
- Tests have verified a very good ageing stability



Installation Recommendations

The level of the average opening and closing pressure can be freely chosen. It is determined by the prestress depending on dimension X - see figure 2.

The dimension X should be designed with the smallest possible tolerances admissible by manufacturing engineering in order to keep the variation of the opening pressure values at a minimum. A tolerance of ± 0.05 mm is recommended.

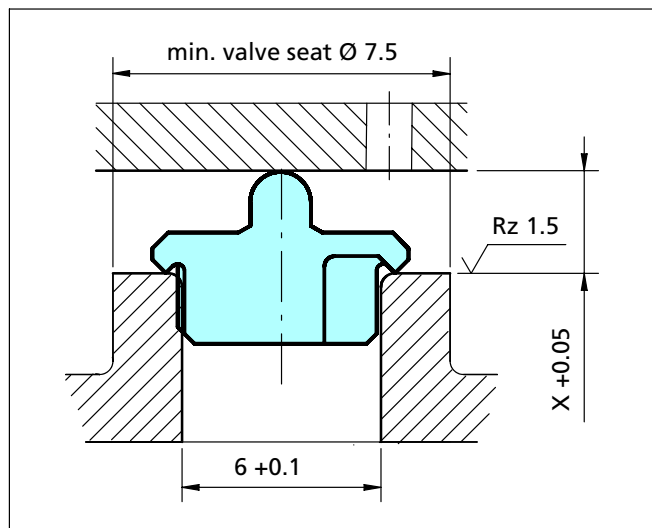

Figure 2 Ventseal-Light Installation

The sealing face of the muff should be polished. Surface quality Rz 1.5; defects, bell mouths and scratches are not admissible.

The transition between sealing face and bore of the muff should have a radius R 0.1 to 0.3 mm. Burrs are not allowed. The cover has to be installed in a vertical direction relative to the muff.

Technical Data

Sealability: up to 50 mbar due to adjustment (dim. X)

Pressure range: 50 - 200 mbar, up to 400 mbar with harder elastomer types

Temperature: -30°C up to +150°C (standard), up to 200°C with other suitable elastomer types

Media: Air, gases, battery acid, KOH and other media with suitable elastomer types

Materials

Function and media resistance depends on the material used. Two standard qualities are available. They are not resistant to mineral oil.

Table I Standard materials

Basic elastomer	Material No.	Hardness	Pressure Range	Temperature
EPDM	E5501	50 Shore A	up to 200 mbar	-50 to +150°C
EPDM	E6601	60 Shore A	> 200 mbar	-50 to +150°C



Ventseal-Light

Opening Pressure

The average opening and closing pressure is determined by the prestress given by dimension X. The diagram shows the value of the opening pressure as a function of the prestressing dimension X.

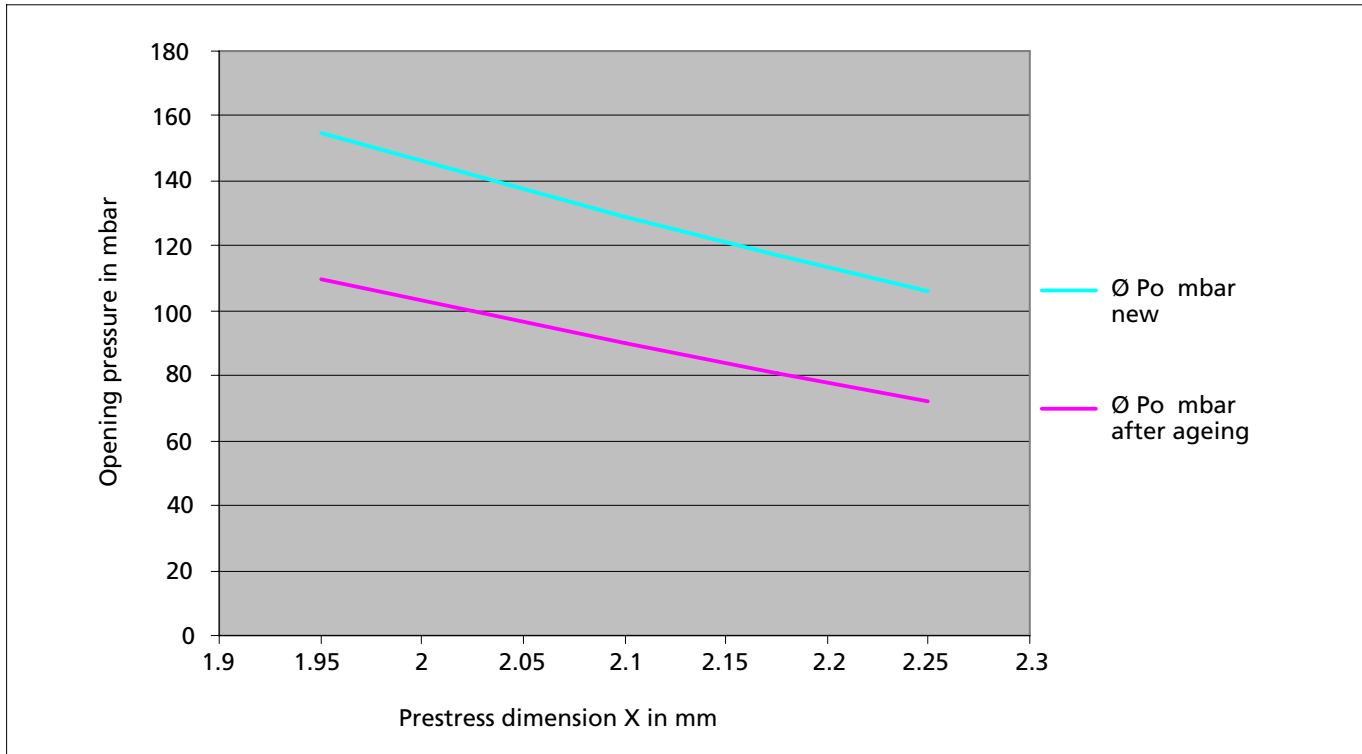

Figure 3 Opening pressure of Ventseal-Light manufactured in material E5501 depending on the prestress dimension X - new and after ageing

The values of the opening pressure are average values only. They have been determined by the rate of flow. In the present case the valve has been evaluated as open at a flow rate of 30 ml/min. Lower flow rates result in lower opening pressure values. Additionally, there are different methods to determine the opening pressure. Therefore we recommend to discuss these values with the user.

The closing pressure value is 10 mbar lower than the opening pressure value.

The lower curve in the above diagram shows the opening pressure value in aged valves.

This value which is determined by the ageing behaviour of the elastomer material is reached after 6 months at room temperature at the latest.

Thereafter, the opening pressure remains constant for the entire service life.

The values of the opening pressure are subject to a certain variation.



This variation is shown in the following diagram.

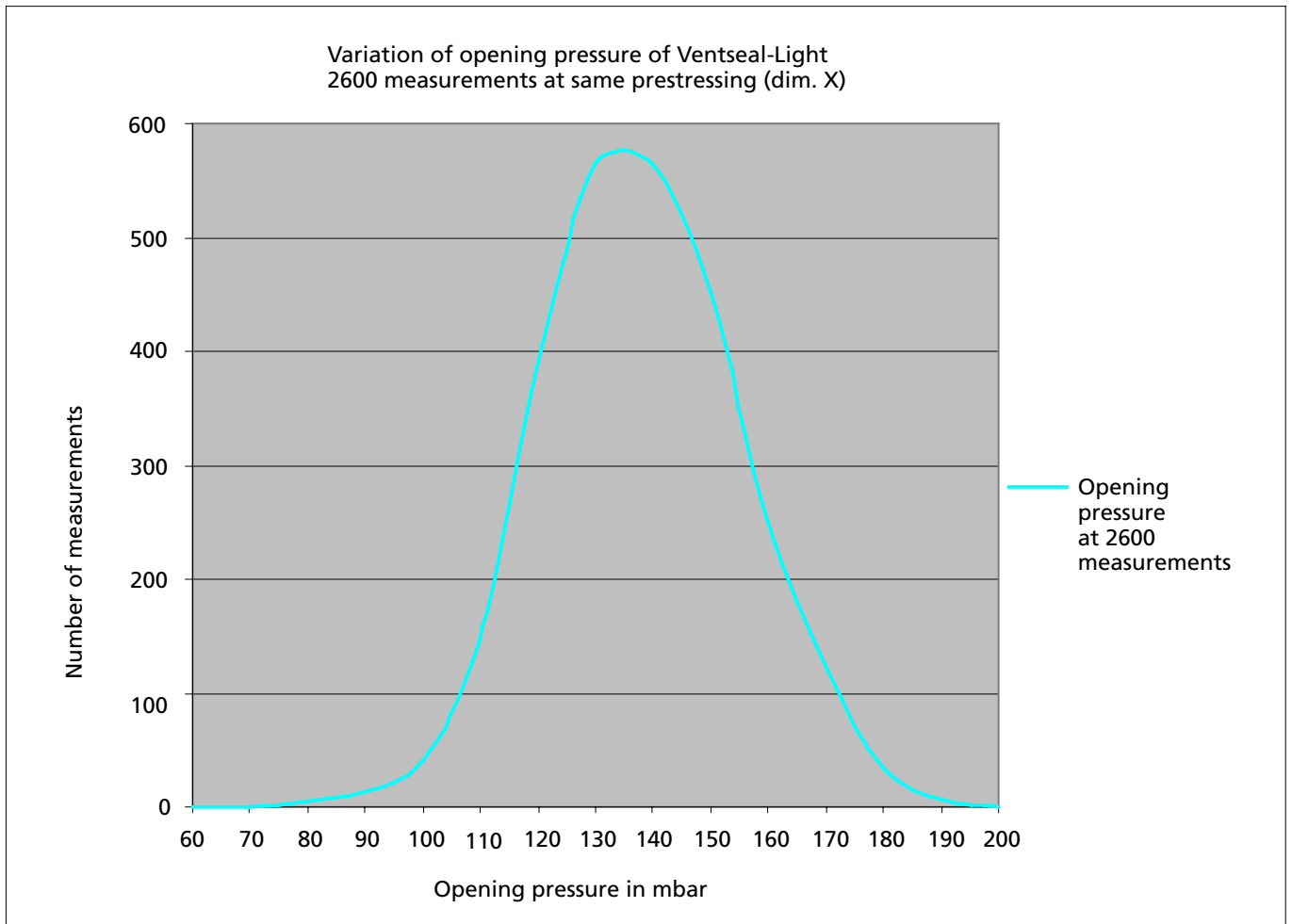

Figure 4 Distribution of the opening pressure values of the Ventseal-Light manufactured in the series tool

These values have been measured with one prestress dimension. To limit the variation it is possible to treat the surface with Krytox oil GLP 105 which is a PTFE solvent with high viscosity. This treatment reduces the variation range by up to 20 %.

At the same time this medium prevents the Ventseal's sealing lip from sticking to the muff surface.

In general, elastomer seals tend to stick to the sealing surface after longer periods of standstill.

Many factors such as surface quality, material combination, installation conditions and lubricant have an influence on the nominal opening pressure.

For this reason we recommend that the user conducts individual tests in order to determine the respective actual pressure and the variation.

Ordering Example

TSS Order No. YB2400060 - E5501

TSS Order No.	YB2400060	-E5501
Ventseal Type	2400	
Muff diameter	6 mm	
Material		

Contact your local marketing company for further information:

Europe	Telephone	Americas	Telephone
AUSTRIA - Vienna <small>(ALBANIA, BOSNIA AND HERZEGOVINA, MACEDONIA, SERBIA AND MONTENEGRO, SLOVENIA)</small>	+43 (0) 1 406 47 33	AMERICAS - REGIONAL	+1 260 749 9631
BELGIUM - Dion-Valmont <small>(LUXEMBOURG)</small>	+32 (0) 10 22 57 50	BRAZIL - São Paulo	+55 11 3372 4500
BULGARIA - Sofia <small>(ROMANIA)</small>	+359 (0)2 969 95 99	CANADA - Etobicoke, ON	+1 416 213 9444
CROATIA - Zagreb	+385 (0) 1 24 56 387	MEXICO - Mexico City	+52 55 57 19 50 05
CZECH REPUBLIC - Rakovnik <small>(SLOVAKIA)</small>	+420 313 529 111	USA, East - Conshohocken, PA	+1 610 828 3209
DENMARK - Hillerød	+45 48 22 80 80	USA, Great Lakes - Fort Wayne, IN	+1 260 482 4050
FINLAND - Vantaa <small>(ESTONIA, LATVIA)</small>	+358 (0) 207 12 13 50	USA, Midwest - Lombard, IL	+1 630 268 9915
FRANCE - Maisons-Laffitte	+33 (0) 1 30 86 56 00	USA, Mountain - Broomfield, CO	+1 303 469 1357
GERMANY - Stuttgart	+49 (0) 711 7864 0	USA, Northern California - Fresno, CA	+1 559 449 6070
GREECE	+41 (0) 21 631 41 11	USA, Northwest - Portland, OR	+1 503 595 6565
HUNGARY - Budaörs	+36 (06) 23 50 21 21	USA, South - N. Charleston, SC	+1 843 747 7656
ITALY - Livorno	+39 0586 22 6111	USA, Southwest - Houston, TX	+1 713 461 3495
THE NETHERLANDS - Barendrecht	+31 (0) 10 29 22 111	USA, West - Torrance, CA	+1 310 371 1025
NORWAY - Oslo	+47 22 64 60 80		
POLAND - Warsaw <small>(LITHUANIA, UKRAINE, BELARUS)</small>	+48 (0) 22 863 30 11	Asia Pacific	Telephone
RUSSIA - Moscow	+7 495 982 39 21	ASIA PACIFIC REGIONAL	+65 6 577 1778
SPAIN - Madrid <small>(PORTUGAL)</small>	+34 (0) 91 71057 30	CHINA - Hong Kong	+852 2366 9165
SWEDEN - Jönköping	+46 (0) 36 34 15 00	CHINA - Shanghai	+86 (0) 21 6145 1830
SWITZERLAND - Crissier	+41 (0) 21 631 41 11	INDIA - Bangalore	+91 (0) 80 2245 5157
TURKEY	+41 (0) 21 631 41 11	JAPAN - Tokyo	+81 (0) 3 5633 8008
UNITED KINGDOM - Solihull <small>(EIRE)</small>	+44 (0) 121 744 1221	KOREA - Anyang	+82 (0) 31 386 3283
AFRICA REGIONAL	+41 (0) 21 631 41 11	MALAYSIA - Kuala Lumpur	+60 (0) 3 9059 6388
MIDDLE EAST REGIONAL	+41 (0) 21 631 41 11	TAIWAN - Taichung	+886 4 2382 8886
		THAILAND - Bangkok	+66 (0) 2732-2861
		SINGAPORE	
		and all other countries in Asia	+65 6 577 1778

www.tss.trelleborg.com

