

# Orkot<sup>®</sup> Bearings

Engineering manual for industrial applications



**Your Partner for Sealing Technology**

# Orkot® Bearings

## Engineering manual for industrial applications



Trelleborg Sealing Solutions is an international group specialized in polymer technology, uniquely placed to offer dedicated design and development from our market leading product and material portfolio; a one-stop shop providing the best in elastomer, thermoplastic, PTFE and composite technologies for sealing and bearing applications in aerospace, industrial, and automotive industries.

With 50-years experience, Trelleborg Sealing Solutions engineers support customers with design, prototyping, production, test and installation using state-of-the-art design tools. An international network of over 70 facilities worldwide includes 30 manufacturing sites, strategically positioned research and development centers, including materials and development laboratories and locations specializing in design and applications.

Developing and formulating materials in-house, we utilize the resource of our material database, including over 2,000 proprietary compounds and a range of unique products.

Trelleborg Sealing Solutions fulfills challenging service requirements, supplying standard parts in volume or a single custom-manufactured component, through our integrated logistical support, which effectively delivers over 40,000 sealing products to customers worldwide.

Facilities are certified to ISO 9001:2000 and ISO/TS 16949:2002. Trelleborg Sealing Solutions is backed by the experiences and resources of one of the world's foremost experts in polymer technology, Trelleborg AB.

**ISO 9001:2000**

**ISO/TS 16949:2002**

The information in this manual is intended to be for general reference purposes only and is not intended to be a specific recommendation for any individual application. The application limits for pressure, temperature, speed and media given are maximum values determined in laboratory conditions. In application, due to the interaction of operating parameters, maximum values may not be achieved. It is vital therefore, that customers satisfy themselves as to the suitability of product and material for each of their individual applications. Any reliance on information is therefore at the user's own risk. In no event will Trelleborg Sealing Solutions be liable for any loss, damage, claim or expense directly or indirectly arising or resulting from the use of any information provided in this manual. While every effort is made to ensure the accuracy of information contained herewith, Trelleborg Sealing Solutions cannot warrant the accuracy or completeness of information.

To obtain the best recommendation for a specific application, please contact your local Trelleborg Sealing Solutions marketing company.

This edition supersedes all previous brochures.  
This brochure or any part of it may not be reproduced without permission.

© All trademarks are the property of Trelleborg AB.  
The turquoise color is a registered trademark of Trelleborg AB.  
© 2008 Trelleborg AB. All rights reserved.

# Contents

General:		Page
	Orkot® Materials	4
	Quality	4
	R+D and Test Facilities	5
	Availability	5
	Grades	6

Properties / Specifications:		Page
	Mechanical Properties	7
	Thermal Properties	8
	Electrical Resistance	8
	Radiation Resistance	9
	Chemical Resistance	9
	Swell	11
	Food and Potable Water Contact	11
	PV and Coefficient of Friction	11
	Un-lubricated or Boundary Lubrication Conditions	12
	Hydrodynamic Applications	12
	Grease lubrication	12

Design information:		Page
	Interference Fit	13
	Wall Thickness	13
	Machining Tolerances	13
	Clearance	14
	Bore Closure	14
	Design Service	14

Design / Installation:		Page
	Lamination Direction	15
	Counter Face	15
	Installation	15
	Application Checklist	16
	Machining Orkot®	16

## Orkot® Materials

Orkot® bearing materials are a range of thermoset composite bearing materials incorporating advanced polymer technologies. These consist of technical fabrics impregnated with thermosetting resins, evenly dispersed solid lubricants and further additives to ensure the optimum solution is reached to satisfy many engineering applications.

Orkot® materials have many advantages over more traditional metallic bearing materials and other polymeric bearings including:

- Low coefficient of friction
- High load capacity
- Good chemical resistance
- Operates in fresh or salt water without lubrication
- Damping of vibration
- Accommodation of shaft misalignment
- Ease of machining
- Fitting by pressing, freezing, adhesives and mechanical methods
- Dimensional stability
- Minimal thermal softening
- Does not encourage galvanic corrosion
- Orkot® contains no asbestos or environmentally hazardous/toxic substances

## Quality

All Orkot® bearings manufactured are subject to strict quality controls and procedures, from raw material acquisition through manufacturing to delivery.

Certification of the production facility is in accordance with international standard BS EN ISO 9001:2000 and meets the specific requirements for quality control and management of purchasing, production and marketing functions.

Many successful applications for Orkot® involve highly loaded bearings or pads operating with intermittent or oscillating movements.

Manufacturing composite bearings since 1954, Orkot® bearings have been fitted and used by thousands of satisfied customers world-wide in a diverse range of applications, including:

- Railways
- Off-road vehicles
- Process equipment
- Injection molding machines
- Pumps and Valves
- Lifting and handling equipment
- Hydropower
- Formula 1 racing cars
- Roll coverings
- Ports, harbors, sluices, sea defense barriers
- Merchant and Navy Shipbuilding (specialized engineering manual available on marine applications)

Accreditation is supported by procedures and processes to ensure full traceability of each component.

A continuous test program ensures the quality and performance of Orkot® bearing materials, and this can be further supported by specific testing and certification of products for customers if required.

## R+D and Test Facilities

The testing laboratories at the factories are equipped to carry out tribological and mechanical tests. Tribological tests are conducted both in linear and rotary geometries, either dry or externally lubricated with fluids (oil, grease, water, etc). Wear and friction data are obtained against a range of counter faces, including those specific to a customer application. Mechanical tests include compressive, tensile, flexural, shear and hardness testing.

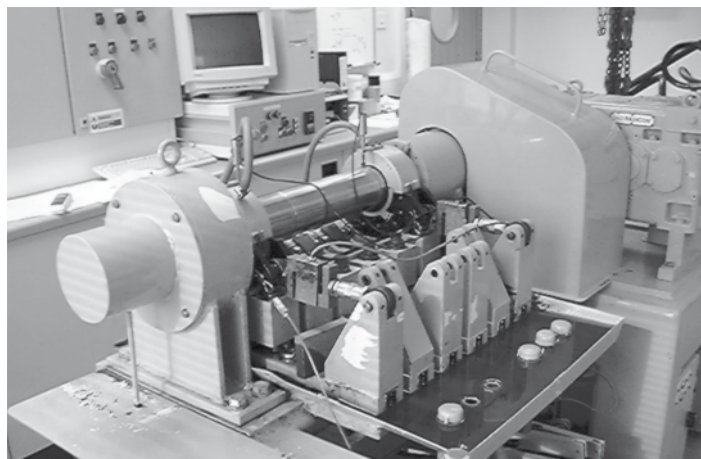

Oscillating test rig

## Availability

Orkot® bearing materials are usually supplied as fully machined components to customers' own drawings. Alternatively, semi-finished materials are supplied in the form of tube or sheet. The following standard range of sizes is available with other sizes on request:

Tube		
	Minimum ID	8 mm
	Maximum OD	2,000 mm
	Standard lengths	340, 500 and 670 mm
Sheet		
	Minimum thickness	1 mm
	Maximum thickness	50 mm
	Maximum width	600 mm
	Maximum length	2,000 mm



Orkot® Bearings

## Grades

Orkot® bearings are manufactured in a range of grades using different combinations of fabrics, resins and additives designed to satisfy many applications.

The commonly used grades have been designated as standard grades, these are shown in the table below.

Many other grades have been developed, even for unusual applications, employing different combinations of standard and specialized fabrics, additives and resin systems.

Please contact TSS Product Management to discuss any projects with unusual conditions for which a special grade may be required.

Grade	Properties	Typical Applications	Coefficient of Friction, typical dry *
C320	standard grade	used against carbon steel, treated surfaces, ceramic or chrome plated counter face	0.15 – 0.20
C321	high electrical resistance	electrical insulators, food applications and structural parts	0.15 – 0.20
C322	standard grade operating in water	used against stainless steel counter face, where water is present or electrical insulation required	0.15 – 0.20
C324	high temperature or chemical resistance	railway brake systems, withstanding high temperature and offering thermal insulation	0.20 – 0.35
C335 / C361	low swell rate and resistance to sea water with limited dry running capability	used against stainless steel counter face, with intermittent water contact or where electrical insulation is required	0.15 – 0.20
C338	high temperature or chemical resistance with added lubricants	guide bearings for high temperature applications	0.20 – 0.25
C369	dry running, low friction, reduced stick-slip and extended life	used against carbon steel, treated surfaces, ceramic or chrome plated counter face	0.05 – 0.10
C378	dry running, low friction, reduced stick-slip and extended life	used with stainless steel counter face, where water is present or electrical resistance required	0.05 – 0.10
C380	high wear resistance and good sliding properties	standard wear ring material for use in hydraulic cylinders, see separate specialized application catalog for more information	0.15 – 0.20
C410	silent operation, stick-slip minimized, dry running capability	materials handling equipment and industrial processing, off highway heavy lift and transport, fluid power when stick-slip or poor lubrication are issues	0.05 – 0.10

\* The coefficient of friction values indicated are typical only and can vary with load, speed, counter face material and any contamination present.

## Properties / Specifications

Orkot® Grade	C320 / C321 / C322 C335 / C361 / C380	C324 / C338	C369 / C378	C410
Ultimate Compressive Strength (N/mm <sup>2</sup> )	300	350	280	280
Shear Strength (N/mm <sup>2</sup> )	80	80	80	80
Tensile Strength (N/mm <sup>2</sup> )	55	60	55	55
Compressive Modulus of Elasticity (N/mm <sup>2</sup> )	2800	3400	2800	2800
Hardness (Rockwell M)	100	105	100	80
Density (g/cm <sup>3</sup> )	1.25	1.25	1.25	1.25

Note, all data based on tests to BS EN ISO 604:1997, BS EN ISO 178:1997, BS 2782:1993 and Orkot® standard methods.

## Mechanical Properties

Under compressive load, standard Orkot® grades behave in an elastic manner up to a yield point. Beyond this, permanent deformation may occur. The yield point relates to the shape of the part and to some extent to the operating temperature.

To keep a safe distance from the yield point when designing a bearing, our general recommendation is for most static applications a maximum design load of 80 N/mm<sup>2</sup>, with 40 N/mm<sup>2</sup> maximum for dynamic applications. However, dynamic application is also dependant on the PV (pressure × velocity) value (see page 12).

These values are with fully supported bearing surfaces and forces perpendicular to the laminations. For forces applied parallel to the laminations, such as on the end face of a flanged bush, only light loads should be used, typically to a maximum of 40 N/mm<sup>2</sup> for static loading and 20 N/mm<sup>2</sup> for dynamic. Higher loads may require the use of, for example, separate thrust washers made from a flat laminate sheet.

Higher load values than those indicated above have been used for specific applications.

Please contact TSS Product Management for assistance if your applications exceeds these values.

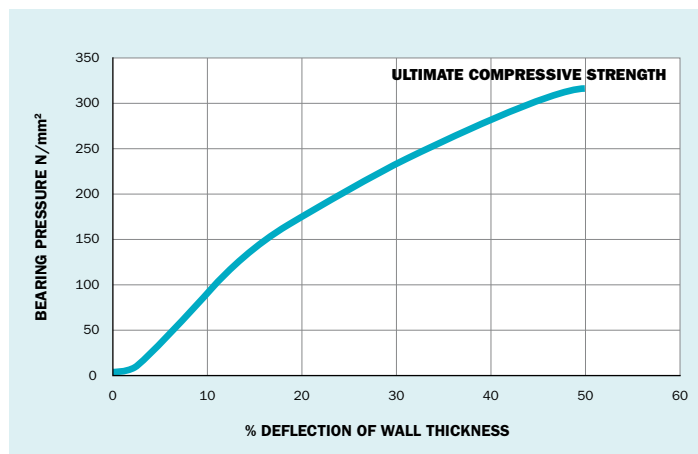

Typical deflection under load for a cylindrical bearing

As with all composite bearings, the effective Elastic Modulus in an application for Orkot® materials is very dependent upon the shape of the component and the support provided for it. Modulus values for Orkot® standard grades range from 800 N/mm<sup>2</sup> to 3000 N/mm<sup>2</sup>. Thus, calculating the deformation of a pad or the degree by which a shaft moves off the center line when under load is complex and depends on the wall thickness, any shaft misalignment and the bearing clearance.

Please contact TSS Product Management for assistance if bearing deflection is important in your application.

## Thermal Properties

Orkot® materials have low thermal conductivity and operate as thermal insulators. As with all polymer bearing materials, the thermal expansion of Orkot® must be taken into consideration during the design process, particularly when operating at higher temperatures or with components having thick sections. As a laminate material, the coefficient of thermal expansion is different perpendicular or parallel to the layers.

The wall thickness of a bush should be kept to a minimum to limit the effect of thermal expansion and to better control clearance levels.

Application at the extremes of temperature depends on the design of the component and the fixation method used. For example, an interference fit can be used from -30 °C to +60 °C whereas a split ring mounted in a groove housing can be used between -60 °C and +130 °C.

Grades C324 and C338 were specifically developed for high temperature applications.

Please contact TSS Product Management for advice on cryogenic or high temperature applications.

Property		Standard Grades	High Temperature Grades C324 / C338
Coefficient of thermal expansion perpendicular to laminations	10 <sup>-5</sup> /°C	9 – 10 (-40 °C to +130 °C)	4 – 5 (-40 °C to +250 °C)
Coefficient of thermal expansion parallel to laminations	10 <sup>-5</sup> /°C	5 – 6 (-40 °C to +130 °C)	2 – 3 (-40 °C to +250 °C)
Thermal Conductivity	W/m °K	0.293	0.169
Minimum and maximum operating temperatures*		Cryogenic to +130 °C	Cryogenic to +250 °C

\* Correct operation at upper extremes of temperature depends upon application

## Electrical Resistance

Orkot® materials are suitable for applications in which interference with magnetic or electric fields must be prevented. They also exhibit electrical insulation properties and have been used in many electrical applications in generators, motors, switches and transformers.

Orkot® is non-magnetic and does not build up static charges and can be used as a general construction material in the electrical engineering industry.

C321 should normally be used and the properties for this are indicated below:

Property	Value
Insulation resistance MOhm	2000
Dielectric strength at +90 °C, V/mm (perpendicular to the fabric laminations)	210
Dielectric constant up to 1 MHz (permittivity)	3.1

## Radiation Resistance

Orkot® components have been successfully used in nuclear and irradiated environments. However, as with all polymer materials, the mechanical properties of Orkot® are effected by exposure.

While these changes may be very small, please contact TSS Product Management to discuss applications.

## Chemical Resistance

Orkot® materials are resistant to many chemicals. They do not corrode and are unaffected by many solvents, inorganic solutions and weak acids. Water based chemicals can also act as lubricants. Standard grades are attacked by chemicals such as ketones, chlorinated solvents, strong alkalis and hot strong oxidizing agents. However, C324 and C338 grades provide additional chemical resistance.

Chemical resistance is affected by many issues such as temperature, concentration, etc. Over the years the manufacturer collected substantial application and laboratory testing information and will be pleased to review any application involving aggressive media. However, the following table provides some information regarding the chemical resistance of standard grades and C324 / C338:

	A	B
Acetaldehyde	N	N
Acetic Acid 75%	N	Y
Acetic Acid Glacial	N	N
Acetone	N	N
Alcohol, Amyl	Y	Y
Alcohol, Butyl	N	Y
Alcohol, Ethyl	N	N
Ammonia Liquified Gas	N	N
Ammonia Gas	N	N
Ammonium Hydroxide	N	N
Benzene	N	Y
Bleaches		
- Calcium Hyperchlorite	Y	Y
- Chlorine Dioxide Wet	Y	Y
- Hydrogen Peroxide	Y	Y
- Lithium Hyperchlorite	Y	Y
- Peroxides Dilute	Y	Y
- Sodium Hyperchlorite < 18%	Y	Y
Brine	Y	Y
Bromine Dry Gas	N	N
Bromine Liquid	N	N

	A	B
Carbon Dioxide Gas	Y	Y
Carbon Monoxide Gas	Y	Y
Carbon Tetrachloride	Y	Y
Carbon Tetrachloride Vapour	Y	Y
Chlorine Hydrochloric Acid Wet 10%	Y	Y
Chlorine Dry Gas	Y	Y
Chlorine Wet Gas	Y	Y
Chloroform	N	N
Chromic Acid	N	Y
Citric Acid	Y	Y
Copper Nitrate	Y	Y
Cumene	N	Y
Cyclohexane	N	Y
Deionized Water	Y	Y
Demineralized Water	Y	Y
Detergents Organic pH 9–12	Y	Y
Detergents Organic pH > 12	N	Y
Diesel Fuel	Y	Y
Diethyl Ether	N	N
Distilled Water	Y	Y
Ethanol	N	N

A = C320 / C321 / C322 / C335 / C361 / C369 / C378 / C410  
B = C324 / C338

Y = Acceptable in application  
N = Unsuitable for application

All data refers to temperatures up to +50°C, beyond this consult TSS Product Management

# Properties / Specifications

	A	B
Ethyl Acetate	N	N
Ethylene Glycol	Y	Y
Fatty Acids	Y	Y
Fluorine Gas	N	N
Formaldehyde	N	Y
Formic Acid	N	N
Gasoline/Petroleum Leaded	Y	Y
Gasoline/Petroleum Aviation	Y	Y
Gasoline/Petroleum Unleaded	N	Y
Glucose	Y	Y
Glycerine	Y	Y
Glycol	Y	Y
n-Heptane	Y	Y
Hexane	Y	Y
Hydrobromic Acid < 25%	Y	Y
Hydrobromic Acid 50%	N	Y
Hydrobromic Acid 60%	N	N
Hydrochloric Acid < 25%	Y	Y
Hydrochloric Acid 40%	N	Y
Hydrochloric Acid + Organics	N	N
Hydrofluoric Acid 10%	N	Y
Hydrofluoric Acid 20%	N	N
Hydrogen Bromide Wet Gas	Y	Y
Hydrogen Chloride Dry Gas	Y	Y
Hydrogen Chloride Wet Gas	Y	Y
Hydrogen Fluoride Vapor	Y	Y
Hydrogen Peroxide 30%	Y	Y
Iodine Crystals	Y	Y
Iodine Vapor	N	Y
Isopropyl Alcohol	N	Y
Jet Fuel JP-4	Y	Y
Kerosene	Y	Y
Lactic Acid	Y	Y
Latex Solution	N	Y
Magnesium Hydroxide	Y	Y
Mercury	Y	Y
Methyl Alcohol (Methanol) 5%	Y	Y

	A	B
Methyl Alcohol (Methanol) 100%	N	N
Methyl Ethyl Ketone	N	N
Naphtha	Y	Y
Naphthalene	Y	Y
Nitric Acid 5%	Y	Y
Nitric Acid 10%	Y	Y
Nitric Acid 20%	N	Y
Nitric Acid 40%	N	N
Oil Crude Sour	N	Y
Oil Crude Sweet	N	Y
Oleum	N	N
Olive Oils	Y	Y
Peroxide Bleach	Y	Y
Phenol	N	N
Phosphoric Acid	Y	Y
Potassium Hydroxide 25%	Y	Y
Potassium Hydroxide 45%	N	Y
Propylene Glycol	Y	Y
Sodium Chloride	Y	Y
Sodium Hydroxide 10%	Y	Y
Sodium Hydroxide 25%	N	Y
Sodium Hydroxide 50%	N	Y
Soy Sauce	N	Y
Soya Oil	Y	Y
Stearic acid	Y	Y
Styrene	N	Y
Sugar Beet Liquor	Y	Y
Sugar Cane Liquor	Y	Y
Sugar/Sucrose	Y	Y
Sulphuric Acid 25%	Y	Y
Sulphuric Acid 70%	N	Y
Sulphuric Acid 80%	N	Y
Sulphuric Acid 90%	N	N
Tetrachloroethane	N	Y
Toluene	N	Y
Trichloroethane	N	Y
Xylene	N	Y

A = C320 / C321 / C322 / C335 / C361 / C369 / C378 / C410  
 B = C324 / C338

Y = Acceptable in application  
 N = Unsuitable for application

All data refers to temperatures up to +50 °C, beyond this consult TSS Product Management

## Swell

In Orkot® material the swell in water, a common issue when using polymers, is only minimal. Taking normal running clearances into account it is so small that no extra allowances are required.

Swell rate for Orkot® standard grades; expressed in change of the wall thickness < 0.1 % and for C324 and C338 grades < 1 %.

## Food and Potable Water Contact

Within the Orkot® range of materials there are designated grades which are safe for contact with food, with all constituents listed by the Food and Drug Administration (FDA). The materials available include compounds which, by use of special resin systems, offer improved temperature and cleaning chemical resistance compared with many traditional plastic materials. The dispersed PTFE lubricant used by Orkot® is also FDA listed.

C322 (TLM) has been approved for cold water applications following extensive testing to BS 6920 (2000) in accordance with the Water Regulations Advisory Scheme (WRAS).

Further information on these approvals is available on request.

## PV and Coefficient of Friction

A major advantage of Orkot® materials is their ability to withstand high loads with intermittent / oscillating movement. However, as with many polymer bearing materials, consideration must be given to the sliding faces causing frictional heat if moving for long periods.

Additives included in Orkot® materials reduce the coefficient of friction and thus the heat generation. This can be further improved by use of external lubricants in the form of oil, grease, water or other process chemicals.

Many factors effect the coefficient of friction for a bearing, particularly the counter face surface finish, bearing pressure and contamination. The continuous operation of any plain bearing is limited by frictional heat generation.

Please contact TSS Product Management for assistance if the coefficient of friction is critical to an application.

For information, the following table indicates some typical values found in oscillating motion with bearing pressures between 10 N/mm<sup>2</sup> and 80 N/mm<sup>2</sup>:

Orkot® Grade	C320	C322	C338	C369	C378	C410
Counter Face	Chrome Steel	316 S/Steel	316 S/Steel	34CrNiMo6 (EN24)	316 S/Steel	316 S/Steel
Lubrication	Hydraulic Oil	Water	Dry	Dry	Dry	Dry
Static Coefficient of Friction	0.13	0.28	0.25	0.10	0.10	0.10
Dynamic Coefficient of Friction	0.07	0.18	0.13	0.05	0.05	0.05

## Un-lubricated or Boundary Lubrication Conditions

Tests have indicated a continuous running PV for C320 of  $14 \text{ N/mm}^2 \cdot \text{m/min}$  when operating dry and  $34 \text{ N/mm}^2 \cdot \text{m/min}$  when grease lubricated.

- Typical PV graph for C320 shows limits for continuous operation.
- Higher PV values are successfully used with intermittent movement. (Consult TSS Product Management).

The PV value in application is affected by many factors including counter face surface finish, bearing pressure and speed and the test values indicated above should be used as a design guide only. For intermittent movement, PV values higher than these can be used if the period of movement is short enough to prevent excessive frictional heat generation. An example of this is indicated on the graph ( $\oplus$ ) for components in a lifeboat launching mechanism having a PV of  $1250 \text{ N/mm}^2 \cdot \text{m/min}$ .

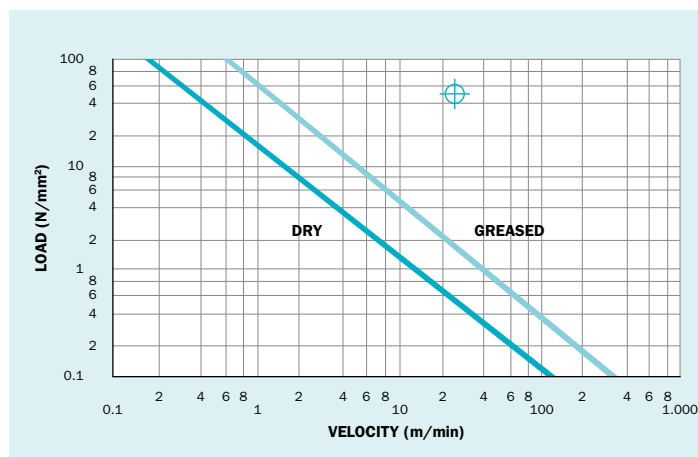

## Hydrodynamic Applications

In high-speed applications in the presence of water or water based liquids, such as pump bearings and hydropower turbine main shaft bearings, hydrodynamic running may be achieved and considerably higher PV values are possible.

The following criteria must be met for hydrodynamic running:

1. Velocity / pressure  $> 320$  where,
  - velocity is the surface speed, m/min
  - pressure is the load/projected bearing area,  $\text{N/mm}^2$ .
2. A positive flow of water is provided

The performance of a polymer bearing is affected by various parameters and any quoted values are relevant to the test conditions only. TSS have many years of experience of supplying Orkot® for a wide range of applications, supported by extensive laboratory testing results, and are able to offer advice for any situation.

Please contact TSS Product Management for assistance with any applications.

## Grease Lubrication

The majority of commercially available lubricants are acceptable for use with Orkot®. Grease may need to be refreshed at regular intervals to ensure it does not dry out. The use of heavily filled grades containing a high percentage of solid lubricants may interfere with the lubricants in the Orkot® material. Therefore, in general the use of such lubricants is not recommended. However it depends from the application, if required careful testing is suggested.

## Interference Fit

Within the range -30 °C to +65 °C, bushes are preferably fitted with interference, and fully supported over the length of the bush. Because of the nature of polymer materials, the interference will necessarily be higher than for metallic bearings. Thus the machined dimensions will need to be modified when changing from metal to Orkot® .

The value of interference varies with the size of the bush and is a balance between the wall pressure and hoop stress. The interference between bush and housing creates a wall pressure between the two parts. This needs to be above a minimum value to ensure that the bush does not move in application. However, excessive interference will lead to hoop stresses in the bush above the design limit of the material, resulting in permanent material deformation.

The interference level also varies with wall thickness and minimum temperature expected during operation. A typical interference curve is indicated on the graph:

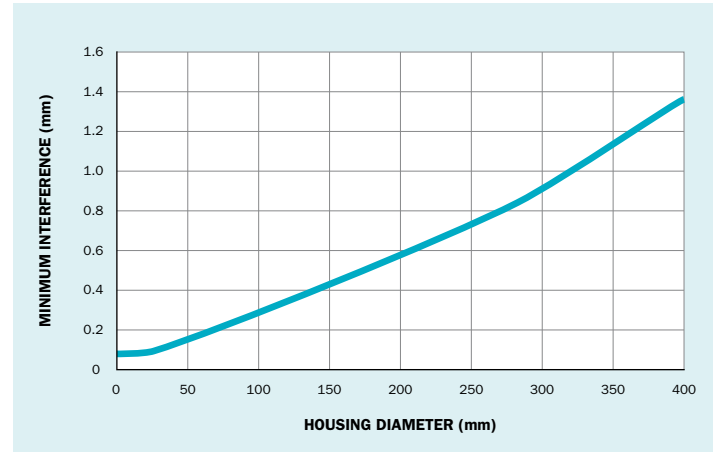

This interference is used with the housing and bush diameter machining tolerances to determine the bush outside diameter. The use of an interference fit to hold a bearing requires a reasonable machined tolerance on the housing bore, typically BS EN 20286-2:1993 H7.

## Wall Thickness

To allow the correct balance of wall pressure and hoop stress with an interference fit, a minimum wall thickness is required for bushes. The minimum wall thickness indicated below should also be used where possible since excessive wall thickness can result in increased clearance requirements to accommodate thermal expansion and swell if used in water. Also, the lower wall thickness allows more accurate control of final fitted bush size.

Thinner wall sections can be used depending on the application details. Please inquire if a thinner wall thickness is required to fit existing hardware. Alternatively, thin walled bushes can be fitted using adhesive or designed as a split ring mounted in a closed groove.

Shaft Diameter (mm)	Minimum Wall Thickness (mm)
6 – 25	1.5
26 – 50	2.5
51 – 75	3.5
76 – 100	5.0
101 – 150	6.5
151 – 200	8.0
201 – 280	10.0
280 – 400	12.0
400 +	Consult TSS

## Machining Tolerances

The following tolerances should be used for the diameters of the Orkot® bush:

Please note that for bearings with a length to diameter ratio over 1, a larger tolerance may be required.

Bearing Outside Diameter (mm)	Manufacturing Tolerance (mm)
10 – 200	0.05
201 – 400	0.10
> 400	Consult TSS

## Clearance

All results are based on a standard temperature of +20 °C. The clearance values used for Orkot® bearings, with shaft diameter of "D", are:

- $0.001 \times D$  for oil or water-based fluid lubricated.
- $0.002 \times D$  for dry running or grease lubricated.

With a minimum of 0.1 mm generally applied in both cases.

The graph indicates the minimum clearances that should generally be used. Certain applications may require reduced clearances. Please consult TSS Product Management if special clearances are required.

The clearance between shaft and a fitted bush depends on the combined dimensions and tolerances of the bush, housing and shaft. Greater control over the clearance can be achieved by fitting the bush with adhesive or machining the bore of the bush after assembly in the housing.

Shaft tolerances should be in line with BS EN 20286-2:1993 g6 or better to control clearance levels.

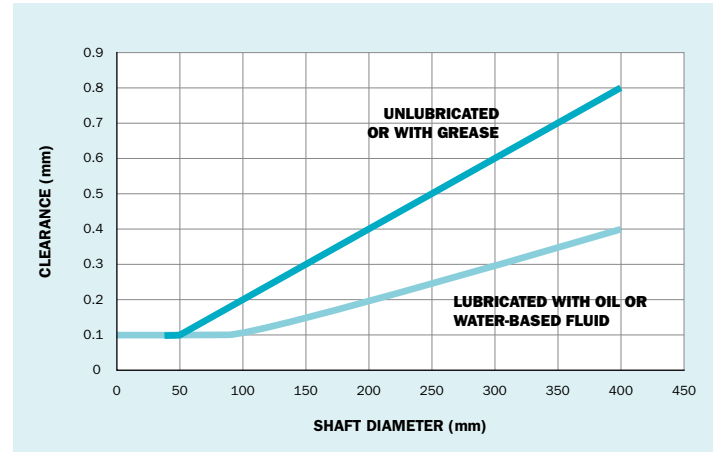

## Bore Closure on Assembly

When a bush is assembled in a housing with an interference, the reduction in OD is transferred to a reduction in fitted ID.

When the recommended wall thickness and interference are followed, 100% of the interference is transferred as a reduction in the ID.

With a thick-walled bush, not all of the interference may be transferred to the ID. Conversely, for thin-walled bushes, a high level of interference may result in the wall thickness increasing, effectively resulting in more than 100% transfer. This effect is also governed by the interference between bush and housing. A typical Bore closure graph is indicated below:

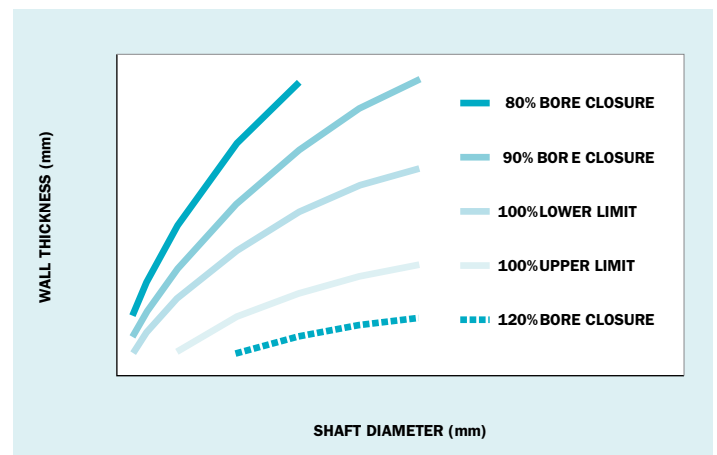

## Design service

The correct design of a bush, including clearance on the shaft and interference in the housing, depends upon many factors.

Trelleborg Sealing Solutions is prepared to review any application and provide technical recommendations including calculation of bush dimensions.

## Lamination Direction

As with all laminated materials, the best results are obtained with the bearing surface parallel to, or concentric with, the layers of the fabric. For example, loads on the end of a flanged bush may require a separate thrust washer.

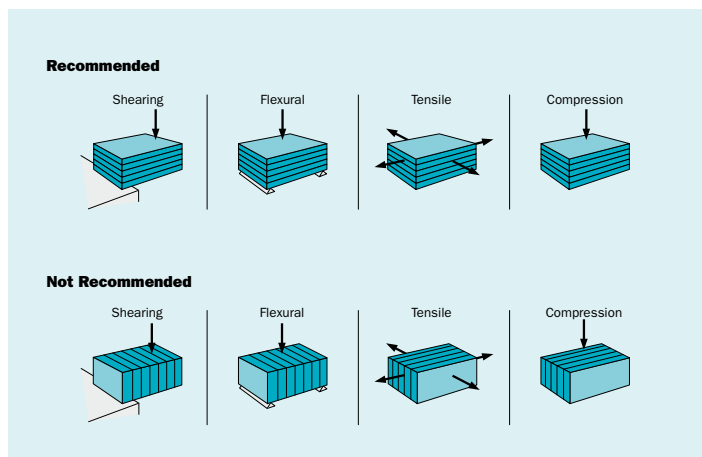

Care must be taken with the design of components subject to compression, bending or shear loads along the direction of lamination.

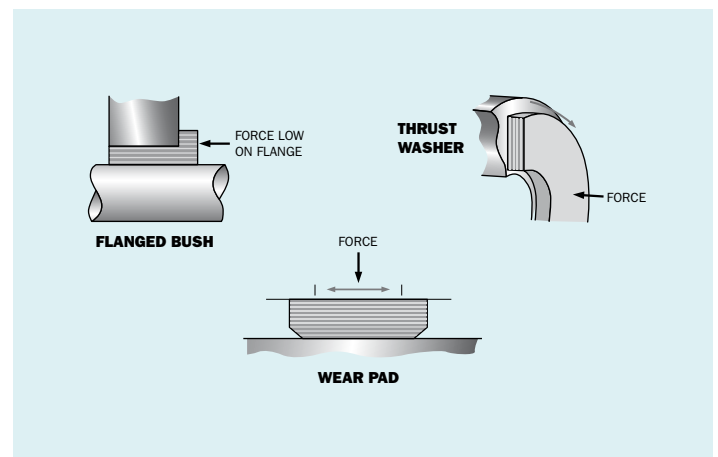

## Counter Face

The counter face has a major effect on the performance of a polymer bearing. The surface finish should preferably be between  $0.1 \mu\text{m}$  and  $0.8 \mu\text{m}$  Ra, and between  $0.4 \mu\text{m}$  and  $0.8 \mu\text{m}$  Ra for grades C369 and C378. There should be no sharp edges and any grease paths or other surface discontinuities. Shafts can have drilled holes to feed grease to the sliding area.

Circular grooves should be machined in the bearing matching the grease feed line, to facilitate grease distribution as well as to prevent damage of the bearing surface at this location. Orkot® materials are successfully used against many different counter face materials, including hardened steel, stainless steel (i.e. 316 or Duplex), gunmetal, chrome plated steel, ceramic coated steel and nitrided surfaces.

## Installation

Where possible, Orkot® bushes should be mounted with an interference fit, with the bearing fully supported over its full length. Suitable shallow chamfers should be used on the housing to prevent damage and bushes should be assembled with a press or drawing-in method. Sharp hammer blows directly onto the Orkot® should be avoided to reduce the possibility of damage to the bush. Correctly shaped drifts should be used. Alternatively, freeze fitting using liquid nitrogen or dry ice can be used without any danger of shattering.

If operating above  $+65^\circ\text{C}$  bonding with an adhesive is recommended. Use of an interference fit, combined with thermal expansion of the bush, can induce stresses in the bush above its elastic limit. The bush may then become loose at low temperatures.

Orkot® can be fitted using various readily available adhesives. Please consult TSS Product Management if any advice is required.

Please contact TSS Product Management for further details of this method if required.

Pads can be retained using counter-sunk bolts. For highly loaded parts, keeper plates or metal washers should be used to provide a more secure fixing method. Alternatively, pads can be recessed in pockets in the carrier.

## Application Checklist

To ensure the correct grade of Orkot® is chosen, and the component design optimized, it is important that all application details are considered.

- Bearing load
- Speed
- Type of movement (rotation or sliding)
- Duty cycle
- Lubrication present

- Chemical or abrasive contamination
- Counter face material and surface finish
- Temperature range of operation
- Application details, what problems are occurring and need to be resolved by using Orkot® .
- Is electrical insulation important?

## Machining Orkot®

### General

Orkot® materials are readily machinable by conventional machine shop techniques. As a general guide, methods used for brass, aluminium or lignum vitae will apply for Orkot® materials. It is preferable to use tungsten carbide turning tools with cutting speeds of 5.5 meters per second. Orkot® materials must be machined dry without the use of coolant.

### Turning

Tungsten carbide tooling of the butt-welded type using K20 grade carbide is suitable for most applications. If carbide inserts are used then aluminium grades with high positive rakes give best results e.g. Plansee grade H10T.

For heavy wall thickness, the internal and external diameters should be machined together to reduce vibration.

No asbestos is used in the manufacturing of Orkot® and the material is completely non toxic. It is however advisable to use adequate dust extraction when machining. If unavailable, operators should wear dust particle masks.

For small volume work and machining of chamfers, radii and other forms, then high-speed steel gives good results, but tool life is shorter than with tungsten carbide.

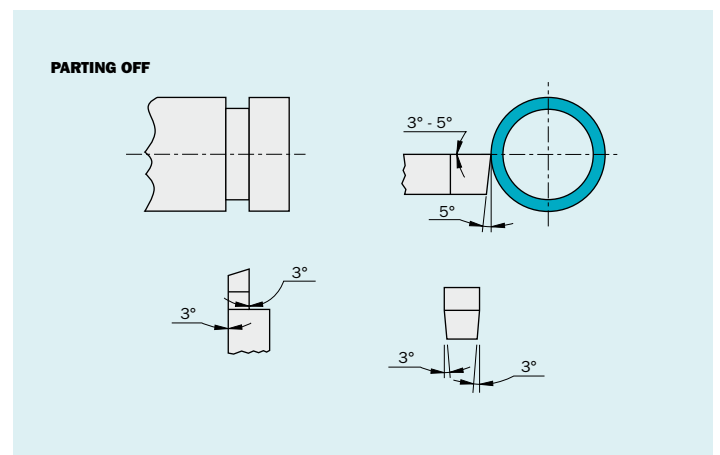
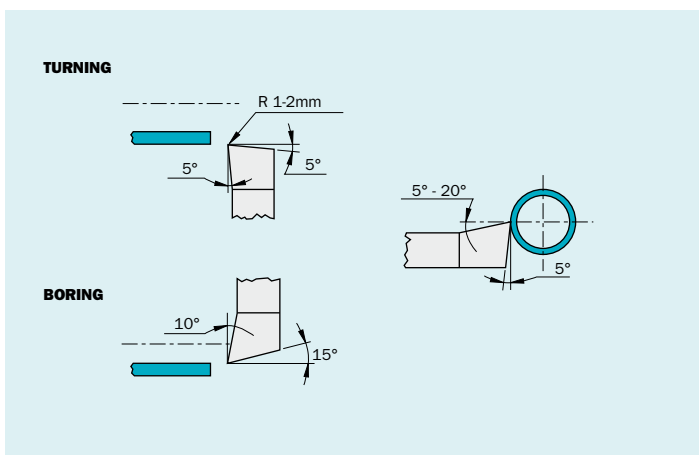







**Contact your local marketing company for further information:**

**Europe**

**AUSTRIA - Vienna**  
(ALBANIA, BOSNIA AND HERZEGOVINA,  
MACEDONIA, SERBIA AND MONTENEGRO, SLOVENIA)

+43 (0) 1 406 47 33

**BELGIUM - Dion-Valmont**  
(LUXEMBOURG)

+32 (0) 10 22 57 50

**BULGARIA - Sofia**  
(ROMANIA)

+359 (0)2 969 95 99

**CROATIA - Zagreb**

+385 (0) 1 24 56 387

**CZECH REPUBLIC - Rakovnik**  
(SLOVAKIA)

+420 313 529 111

**DENMARK - Hillerød**

+45 48 22 80 80

**FINLAND - Vantaa**  
(ESTONIA, LATVIA)

+358 (0) 207 12 13 50

**FRANCE - Maisons-Laffitte**

+33 (0) 1 30 86 56 00

**GERMANY - Stuttgart**

+49 (0) 711 7864 0

**GREECE**

+41 (0) 21 631 41 11

**HUNGARY - Budaörs**

+36 (06) 23 50 21 21

**ITALY - Livorno**

+39 0586 22 6111

**THE NETHERLANDS - Barendrecht**

+31 (0) 10 29 22 111

**NORWAY - Oslo**

+47 22 64 60 80

**POLAND - Warsaw**  
(LITHUANIA, UKRAINE, BELARUS)

+48 (0) 22 863 30 11

**RUSSIA - Moscow**

+7 495 982 39 21

**SPAIN - Madrid**  
(PORTUGAL)

+34 (0) 91 71057 30

**SWEDEN - Jönköping**

+46 (0) 36 34 15 00

**SWITZERLAND - Crissier**

+41 (0) 21 631 41 11

**TURKEY**

+41 (0) 21 631 41 11

**UNITED KINGDOM - Solihull**  
(EIRE)

+44 (0) 121 744 1221

**AFRICA REGIONAL**

+41 (0) 21 631 41 11

**MIDDLE EAST REGIONAL**

+41 (0) 21 631 41 11

**Americas**

**AMERICAS - REGIONAL**

+1 260 749 9631

**BRAZIL - São Paulo**

+55 11 3372 4500

**CANADA - Etobicoke, ON**

+1 416 213 9444

**MEXICO - Mexico City**

+52 55 57 19 50 05

**USA, East - Conshohocken, PA**

+1 610 828 3209

**USA, Great Lakes - Fort Wayne, IN**

+1 260 482 4050

**USA, Midwest - Lombard, IL**

+1 630 268 9915

**USA, Mountain - Broomfield, CO**

+1 303 469 1357

**USA, Northern California - Fresno, CA**

+1 559 449 6070

**USA, Northwest - Portland, OR**

+1 503 595 6565

**USA, South - N. Charleston, SC**

+1 843 747 7656

**USA, Southwest - Houston, TX**

+1 713 461 3495

**USA, West - Torrance, CA**

+1 310 371 1025

**Asia Pacific**

**Telephone**

**ASIA PACIFIC REGIONAL**

+65 6 577 1778

**CHINA - Hong Kong**

+852 2366 9165

**CHINA - Shanghai**

+86 (0) 21 6145 1830

**INDIA - Bangalore**

+91 (0) 80 2245 5157

**JAPAN - Tokyo**

+81 (0) 3 5633 8008

**KOREA - Anyang**

+82 (0) 31 386 3283

**MALAYSIA - Kuala Lumpur**

+60 (0) 3 9059 6388

**TAIWAN - Taichung**

+886 4 2382 8886

**THAILAND - Bangkok**

+66 (0) 2732-2861

**SINGAPORE**

+65 6 577 1778

and all other countries in Asia

[www.tss.trelleborg.com](http://www.tss.trelleborg.com)



**TRELLEBORG**  
SEALING SOLUTIONS