

Wills Rings®

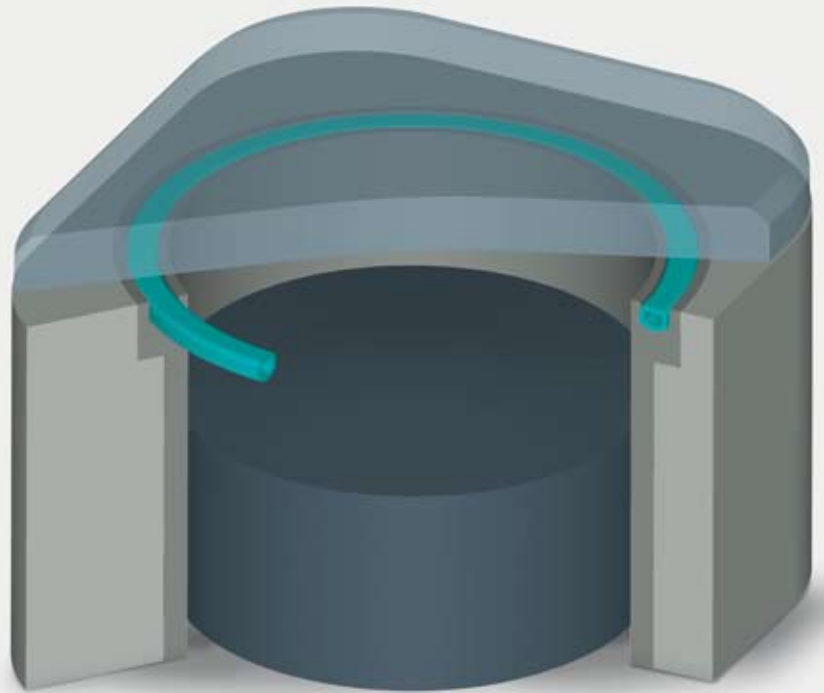

Your Partner for Sealing Technology



Your Partner for Sealing Technology

Trelleborg Sealing Solutions is a major international sealing force, uniquely placed to offer dedicated design and development from our market leading product and material portfolio; a one-stop shop providing the best in elastomer, thermoplastic, PTFE and composite technologies for applications in aerospace, industrial, and automotive industries.

With 50-years experience, Trelleborg Sealing Solutions engineers support customers with design, prototyping, production, test and installation using state-of-the-art design tools. An international network of over 70 facilities worldwide includes 30 manufacturing sites, strategically positioned research and development centers, including materials and development laboratories and locations specializing in design and applications.

Developing and formulating materials in-house, we utilize the resource of our material database, including over 2,000 proprietary compounds and a range of unique products.

Trelleborg Sealing Solutions fulfills challenging service requirements, supplying standard parts in volume or a single custom-manufactured component, through our integrated logistical support, which effectively delivers over 40,000 sealing products to customers worldwide.

Facilities are certified to ISO 9001:2000 and ISO/TS 16949:2002. Trelleborg Sealing Solutions is backed by the experiences and resources of one of the world's foremost experts in polymer technology, Trelleborg AB.

ISO 9001:2000

ISO/TS 16949:2002

The information in this brochure is intended to be for general reference purposes only and is not intended to be a specific recommendation for any individual application. The application limits for pressure, temperature, speed and media given are maximum values determined in laboratory conditions. In application, due to the interaction of operating parameters, maximum values may not be achieved. It is vital therefore, that customers satisfy themselves as to the suitability of product and material for each of their individual applications. Any reliance on information is therefore at the user's own risk. In no event will Trelleborg Sealing Solutions be liable for any loss, damage, claim or expense directly or indirectly arising or resulting from the use of any information provided in this brochure. While every effort is made to ensure the accuracy of information contained herewith, Trelleborg Sealing Solutions cannot warrant the accuracy or completeness of information.

To obtain the best recommendation for a specific application, please contact your local Trelleborg Sealing Solutions marketing company.

This edition supersedes all previous brochures.
This brochure or any part of it may not be reproduced without permission.

© All trademarks are the property of Trelleborg AB.

The turquoise color is a registered trademark of Trelleborg AB.

© 2008, Trelleborg AB. All rights reserved.



Contents

Introduction 3

Method of Operation 4

Selection Table 5

Materials 6

Hardware, Finish and Media 7

Wills Rings® O - Type MOT (Gas Filled) 8

 - Type MOV Internal Pressure (System Pressure Activated) 8

 - Type MOW External Pressure (System Pressure Activated) 8

 - Type MOU Non-Pressurised 9

 - Type MOS Solid 9

 - Special Designs For Non-Circular Grooves 10

Wills Rings® C - Type MCX Internal Pressure/Type MCY External Pressure 11

Size Ranges and Free Heights in Metric 12

Compression Loads to Seat Wills Rings® 13

Calculating Seating Loads 14

Groove Designs 15

Internal Pressure

 Installation Recommendations for Internal Pressure Sealing 17

 Clearance Tolerance Correction Values in Metric 18

 Wills Rings® O for Internal Pressure 19

 Wills Rings® C for Internal Pressure 20

External Pressure

 Installation Recommendations for External Pressure Sealing 21

 Wills Rings® C for External Pressure 22

Part Number and Ordering Instructions in Metric 23

 Part Number Systems for Wills Rings® in Metric 25

Part Number and Ordering Instructions in Inches

 Size Ranges and Free Heights in Inches 28

 Clearance Tolerance Correction Values in Inches 29

 Part Number Systems for Wills Rings® in Inches 30

Quality Criteria 32

Storage 32

Conversion Tables 33





Introduction

Trelleborg Sealing Solutions designs and manufactures a wide range of seals and bearings which are used in many industries and applications. Wills Rings® are metal seals which can be of two fundamental designs:

- a) Wills Rings® O
- b) Wills Rings® C

Wills Rings® are superior controlled compression type seals and are for static applications only. For best sealing results Wills Rings® should be replaced each time the groove housing is dismantled. Wills Rings® have a degree of elastic recovery after being compressed in a housing - but this is not sufficient to guarantee sealing again once the housing has been dismantled.

Wills Rings® are designed for extreme conditions which exceed the capabilities of elastomer and polymer seals.

Wills Rings® O are the original Metal O-Ring seals. Wills Rings® were developed at the Wills factory in Bridgwater, UK. The term 'Wills Rings' is often used internationally to describe Metal O-Ring seals.

Wills Rings® O consist of a tube formed into a circular profile. Wills Rings® C are similar, but they have an open 'C' cross section. The open slot of the Wills Rings® C faces toward the system pressure and allows the seal to be pressure activated.

Wills Rings® are constructed from high quality metal tubing or strip in standard or thin wall thickness, they are often coated or plated with a softer material to increase their sealing performance. There are five types of Wills Rings® depending upon the application (Figure 1).

Typical Applications

- Nuclear power plant
- Furnaces
- Offshore and marine
- Cryogenics
- Extreme vacuum systems
- Fire safe valves
- Plastic processing
- Automotive

The design of Wills Rings® can be modified to suit the specific requirements of a system. These different designs offer a variety of sealing performances.

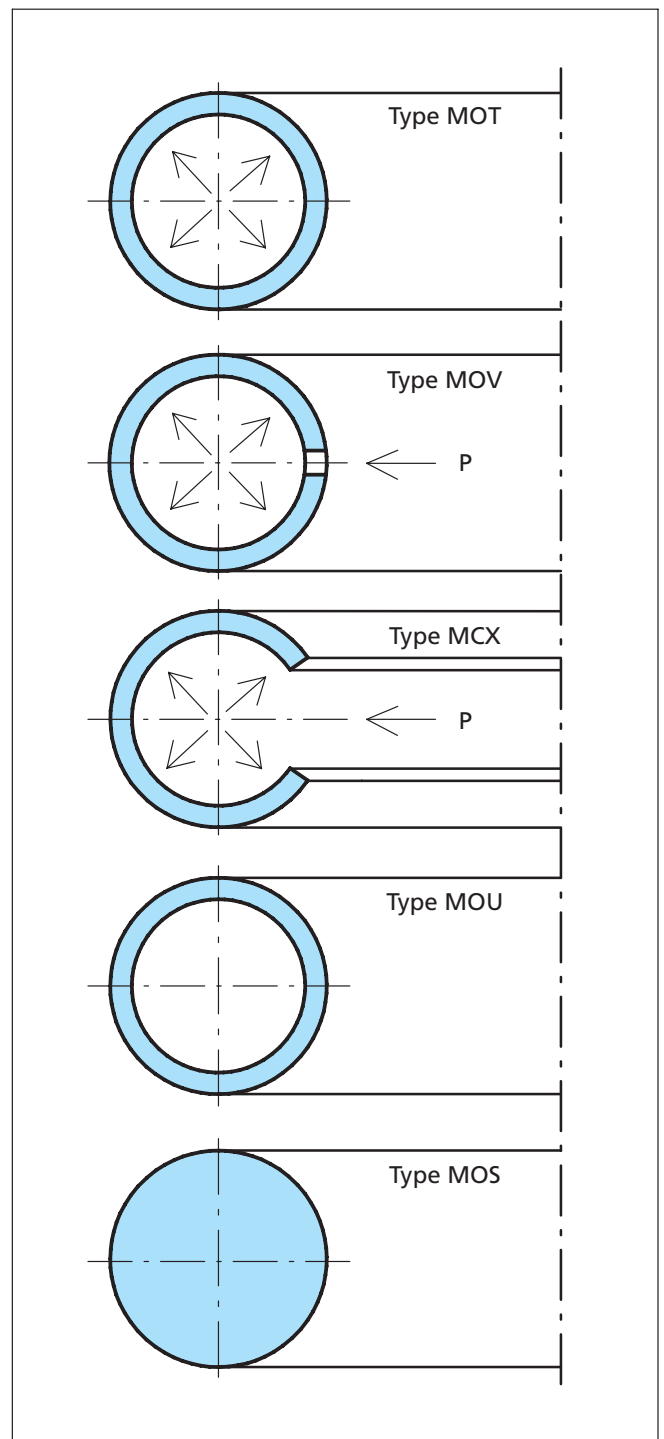

Figure 1 Wills Rings®



Method of Operation

Wills Rings® consist of a metal ring, often coated, which is used as a deformable seal in a static sealing situation. The ring is located between two flanges and undergoes a controlled compression. Wills Rings® are defined by their free height which is the cross section in the axial direction of the seal (Figure 2). The free height d_2 of the seal is compressed down to the groove depth h . The resistance of the ring to compression enables it to form an effective seal when compressed. The resilient effect of the seal is increased by pressurising the internal volume of the ring (see Type MOT gas filled Wills Rings® O).

Alternatively, if the system to be sealed is of very high pressure - this can be used to provide additional sealing effect. This is termed 'system actuation'. This is achieved by allowing the high pressure to enter the seal through either vent holes (see Type MOV), or through the open C slot (see Type MCX, Figure 1).

Wills Rings® seals have a certain degree of elasticity. This is known as "springback". The springback is the elastic part of the seal deflection when it is installed in a groove. This influences the seal's ability to absorb or compensate for hardware variations due to temperature loadings, and thus maintain the seal integrity (Figure 2).

A softer plating/coating material can be applied to Wills Rings® to maximise sealing performance in difficult applications. The soft coating material yields during the ring compression and fills any surface machining marks (Figure 3).

Performance

Because Wills Rings® are constructed from metal, their ability to handle extreme conditions exceeds that of polymeric and elastomeric seal types.

Wills Rings® seals do not "out gas". Outgassing is normally associated with elastomer type seals. Although not a significant amount of gas is emitted, it can be a problem when a seal is used on sensitive equipment.

Advantages

- Temperature range from cryogenic to 850°C/1550°F
- Pressure range from ultra high vacuum to 1000 MPa/145 000 psi
- Compatible with a large range of media
- Corrosion resistant and radiation tolerant
- Simple and reliable sealing
- No "out gassing"
- Wide range of sizes

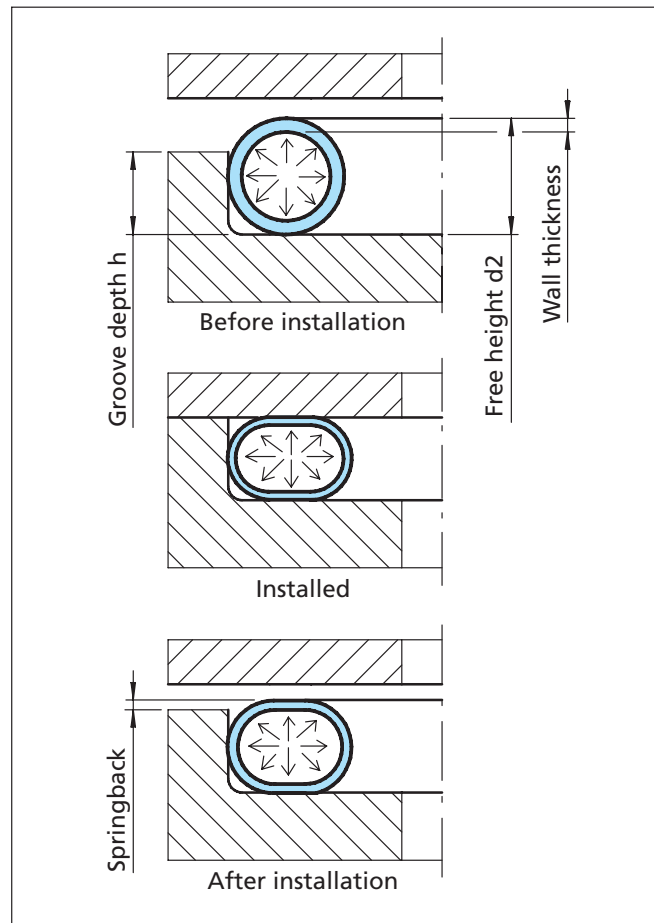

Figure 2 Method of seal operation

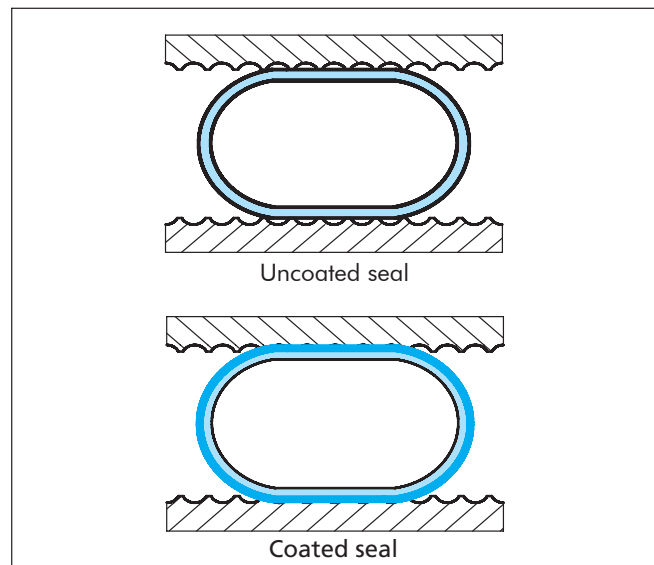

Figure 3 Contact surface for coated and uncoated Wills Rings®







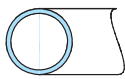

Selection Table

Use this table to select the optimum seal for a given application. The scoring for each seal type indicates relative performance.

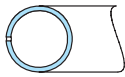
Further information can be found on the relevant pages as indicated.

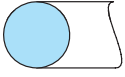
Table I Selection Criteria

Seal		Description	Extreme Conditions	Seating Loads	Page 17	Page 7		Page 6		
Code	Page				Spring-back	Vacuum Sealing	Pressure MPa/psi	Max. Working Temp. °C/°F	Standard Material	
			Note 1)	Note 2)	Note 3)	Note 4)		Cryogenic to	Seal Note 5)	Coating
Type MOT 	8	Pressurized	A	C	C	A	40 MPa 5800 psi	850°C 1550°F	Mild steel Stainless steel 316L 321 Inconel® 600 Copper	PTFE Silver Nickel Copper Gold Indium
Type MOV 	8	Vented internal	B	B	C	C	1000 MPa 145 000 psi	600°C 1100°F		
Type MOW 	8	Vented external								
Type MOU 	9	Non-pressurized	C	B	C	C	4 MPa 580 psi	400°C 750°F		
Type MOS 	9	Solid	C	D	D	B	4 MPa 580 psi	500°C 925°F		
Type MCX 	11	Internal pressure	B	A	A	C	200 MPa 29 000 psi	750°C 1375°F		
Type MCY 	11	External pressure								

Properties: A = Excellent B = Good C = Satisfactory D = Poor

If further information on seal selection is required please contact your local Trelleborg Sealing Solutions office. Inconel® is a trade mark of INCO Alloys International, Inc.

Notes:

- 1) Extreme conditions could be radiation, searching gases, long life.
- 2) Thin wall material should be used to give low seating loads. This must be specified as seals are made in standard wall unless otherwise requested.
- 3) The elastic recovery of the seal is known as the 'Springback'. Springback depends upon wall thickness, and also heat treatment for Wills Rings® C. Higher seal resilience gives higher springback, and higher seating loads.
- 4) Ability to seal a hard vacuum to meet a leakage rate of $Q < 1 \times 10^{-9} \text{ mbar.l.s}^{-1}$
- 5) Other material options are available. Not all materials are available in all sizes! Not all coatings available for all materials. See temperature limitations (Table II).
- 6) MOV/MOW (Vented type Wills Rings® O) seal not available in 0.89 mm (0.035") Free Height size J. Use MOT type or increase to a 1.59 mm (0.063") size instead.



Materials

Seal Base Material

Wills Rings® are used as static seals in a large number of industrial sectors as well as in aerospace. Wills Rings® are available in a wide range of materials. The choice of materials affects the seal performance in many ways. The material must be chosen after considering the following points:

- Pressure and temperature
- Seating loads
- Corrosion resistance
- Compatibility with housing materials
- Life requirements
- Sealing level required
- Cost of seal

The more arduous the conditions, the better the seal material must be.

Plating/Coating Materials for Wills Rings®

The sealing capability of Wills Rings® is greatly enhanced by the addition of a softer coating material (Figure 3)

Table IV gives the technical data for each coating, including the plating thickness, temperature capability and the size range.

Select plating/coating for a given application by considering the system requirements. That is:

1. The level of the sealing needed and the fluid to be sealed.
2. Will the temperature of the system affect the plating ?

Table IV Standard Coating Materials

Coating		Coating-Thickness mm	Temperature		Comments	Max. Ø mm
Material	Code		°C	°F		
PTFE	W	0.030 ± 0.005	260	500	Not available on copper rings	2000
Nickel	Q	0.030 ± 0.005	1200	2200	-	1000
Silver	R	0.030 ± 0.005	800	1475	1 layer silver	1000
Silver	U	0.055 ± 0.005	800	1475	2 layers silver	1000
Silver	S	0.080 ± 0.005	800	1475	3 layers silver	1000

For non-plated rings please omit the plating code from the part number.

Table II Standard Seal Materials, for Wills Rings® O

Standard Material	Temperature		Code
	°C	°F	
Copper	400	750	O
Mild steel	550	1025	B
Stainless steel AISI 316L (1.4435)	800	1475	H
Stainless steel AISI 321 (1.4541)	800	1475	E
Inconel® 600	850	1550	M

Table III Standard Seal Materials, for Wills Rings® C

Standard Material	Temperature		Code
	°C	°F	
Inconel® X750	750	1375	N
Inconel® 718	750	1375	L

Please note:

Not all materials are available in all sizes.

Alternative materials and coatings can be offered.

3. Is the media corrosive to the plating ?
4. For higher levels of sealing, use more layers of plating combined with a better surface finish.
Note: increased plating and a better surface finish make the seal and the hardware more expensive to produce.
5. For less critical applications - non-plated rings may provide sufficient sealing.

Do not hesitate to contact our technical department for further information.



■ Hardware, Finish and Media

Table V shows the media which can be sealed with different plating materials and the required surface finish for the housing. It is important that all machining marks are concentric with the line of the seal contact. Spiral or radial marks should be avoided as these can form leak paths across the seal face.

The groove should be machined to the required finish (and not polished). Polishing can lead to radial marks on the sealing surface which may form leak paths.

Typically a thinner gas is more difficult to seal (than a heavy liquid), and requires a better surface finish. The lower the media viscosity, the higher the surface finish quality and plating level should become.

Table V Media and Hardware Surface Finishes

Sealing System/Media	Ra μ m	Rmax μ m	Typical Coating	Comments
Ultra high vacuum	0.1 - 0.2	1.2 - 1.6	S	Use this for safety critical systems
Cryogenic - High vacuum	0.1 - 0.2	1.2 - 1.6	S	
Helium, Hydrogen	0.1 - 0.2	1.2 - 1.6	S	
Nitrogen, Steam	0.2 - 0.4	2.0 - 2.5	R/S/W/Q	-
Cryogenic - Light vacuum	0.2 - 0.4	2.0 - 2.5	R/S/W/Q	-
Air, Water, Light fuel	0.4 - 0.8	3.0 - 4.0	R/W/Q	Non-plated rings may be suitable
Heavy oils, Polymer	0.4 - 0.8	3.0 - 4.0	R/W/Q	



■ Wills Rings® O Type MOT (Gas Filled)

The most frequently used Wills Rings® are filled with nitrogen gas. The gas pressure inside the seal rises with temperature to offset the loss of tubing strength at elevated temperatures.

Advantages

- High temperature capability
- Available in a wide range of materials and finishes
- Resistant to corrosion and chemical attack
- Resistant to radiation
- Long Life

Technical Data

Operating pressure: Vacuum - helium tight
 1×10^{-9} mbar.l.s⁻¹

High pressure: up to 40 MPa/5800 psi

Temperature: Cryogenic to 850°C/1550°F
 (constant temp.)

Seal type: Internal and external sealing

Standard materials: Stainless steel

Coating material: Silver recommended

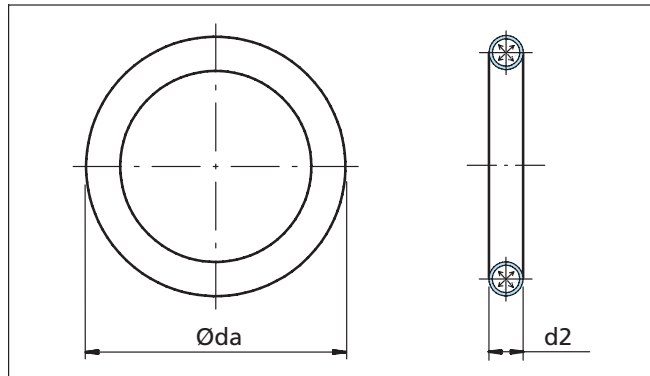

Figure 4 Wills Rings® O - Type MOT

■ Wills Rings® O Type MOV Internal Pressure Type MOW External Pressure (System Pressure Actuated)

These seals are ideal for extreme pressure applications. System pressure is allowed to actuate the seal ring through vent holes on the seal wall. The vent holes are on the inside diameter for internal pressure (Type MOV), and on the outside diameter for external pressure (Type MOW).

These vent holes enable the internal pressure of the seal to be equal to the system pressure.

Advantages

- High pressure capability
- Available in a wide range of materials and finishes
- Resistant to corrosion and chemical attack
- Resistant to radiation
- Long life

Technical Data

Operating Pressure: High pressure: from 7 to 1000 MPa/1015 to 145 000 psi

Temperature: Cryogenic to 600°C/1100°F
 (constant temp.)

Seal type: Internal and external pressure sealing

Standard materials: Stainless steel

Coating material: Silver recommended

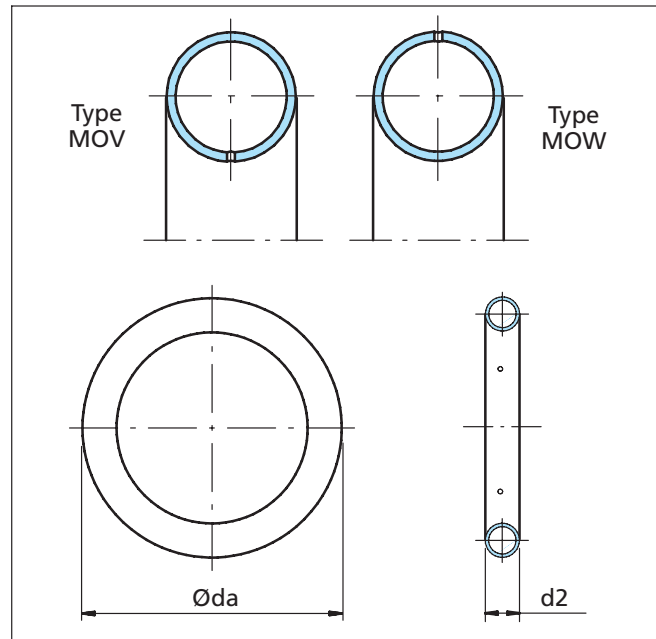

Figure 5 Wills Rings® O - Type MOV/MOW



■ **Wills Rings® O**
Type MOU Non-Pressurised

These are Wills Rings® O seals for low sealing requirements. They have gas filling at atmospheric pressure only and this limits the safe maximum working temperature.

Advantages

- Available in a wide range of materials and finishes
- Resistant to corrosion and chemical attack
- Long Life
- Cost effective in less demanding applications

Technical Data

Operating pressure: Vacuum - bubble tight
 1×10^{-5} mbar.l.s⁻¹
 Pressure - up to 4 MPa/580 psi

Temperature: Cryogenic to 400°C/750°F

Seal type: Internal and external pressure sealing

Seal materials: Stainless steel

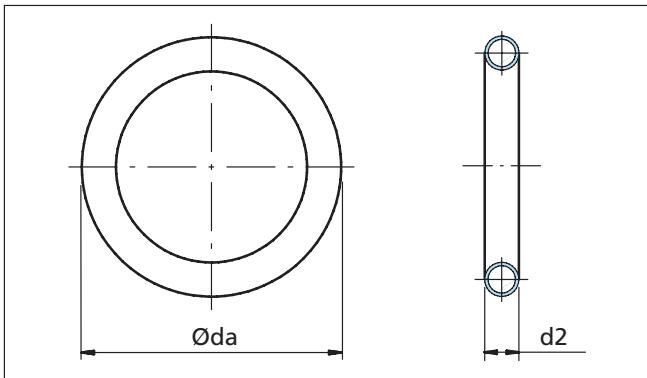

Figure 6 Wills Rings® O - Type MOU

■ **Wills Rings® O**
Type MOS Solid

These are crush seals which operate in similar manner to gasket sealing. Solid seals exhibit virtually no elastic behaviour and also have very high seating loads.

Advantages

- Good vacuum sealing capability
- Available in a wide range of materials and finishes
- Resistant to corrosion and chemical attack
- Long Life
- Cost effective in less demanding applications

Technical Data

Operating pressure: Vacuum - bubble tight
 1×10^{-5} mbar.l.s⁻¹
 Pressure - up to 4 MPa/580 psi

Temperature: Cryogenic to 500°C/925°F

Seal type: Internal and external pressure sealing

Seal materials: Stainless steel and copper

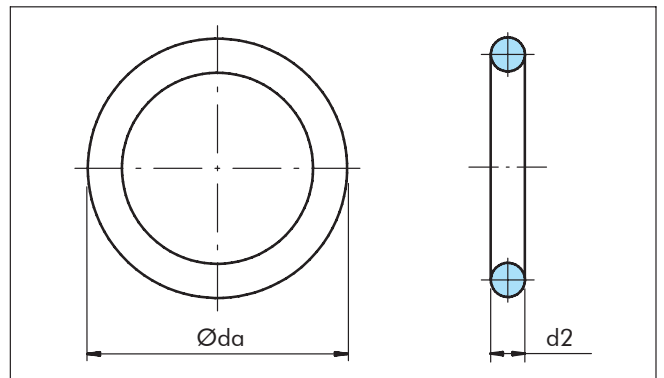

Figure 7 Wills Rings® O - Type MOS



■ Wills Rings® O Special Designs For Non-Circular Grooves

Wills Rings® O are also supplied in a variety of specially manufactured shapes to accommodate non-circular flanges and vessels. In the design of form seals the minimum bending radius in relation to the free height must be observed (Table VI). This is different to the minimum seal diameter for a given seal free height.

(Figure 8 examples of non-circular seals).

Table VI Minimum Bending Radius for Wills Rings® O

Free Height d2 [mm]	Min. Bending Radius [mm]
1.59	7
2.38	13
3.18	30
3.97	50
4.76	75
6.35	100
7.94	200
9.53	300

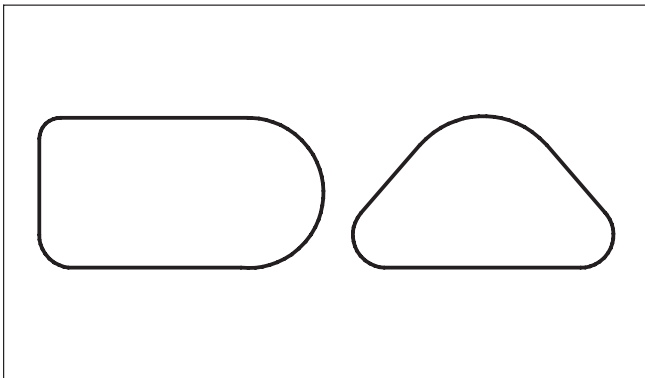

Figure 8 Examples of non-circular seals

For further information on special seal designs please contact your local Trelleborg Sealing Solutions office.



■ **Wills Rings® C**
Type MCX Internal Pressure
Type MCY External Pressure

System pressure is allowed to actuate the seal through a vent slot in the C profile which runs around the entire circumference of the seal. This slot is internal for internal pressure, and external for external pressure.

Another benefit of this seal type is the increased amount of seal springback. This can be triple the amount exhibited by metal O-Ring seals.

Also, by using a thin wall section, low seating loads can be achieved for Wills Rings® C.

Advantages

- Low seating loads
- High springback
- Good pressure capability
- Good temperature capability
- Corrosion resistant
- Radiation resistant
- Long Life

Technical Data

Pressure:	Vacuum - bubble tight 1×10^{-5} mbar.l.s ⁻¹ to 200 MPa/29 000 psi
Temperature:	Cryogenic to 750°C/1375°F
Seal type:	Internal and external pressure sealing
Seal materials:	Inconel® X750 Inconel® 718
Coating materials:	Silver PTFE

Note:

For internal pressure, Wills Rings® C Type MCX are sized to their outside diameter, Ø da.

For external pressure, Wills Rings® C type MCY are sized to their inside diameter, Ø di.

Hence, the Wills Rings® C is always sized to the back of the C profile.

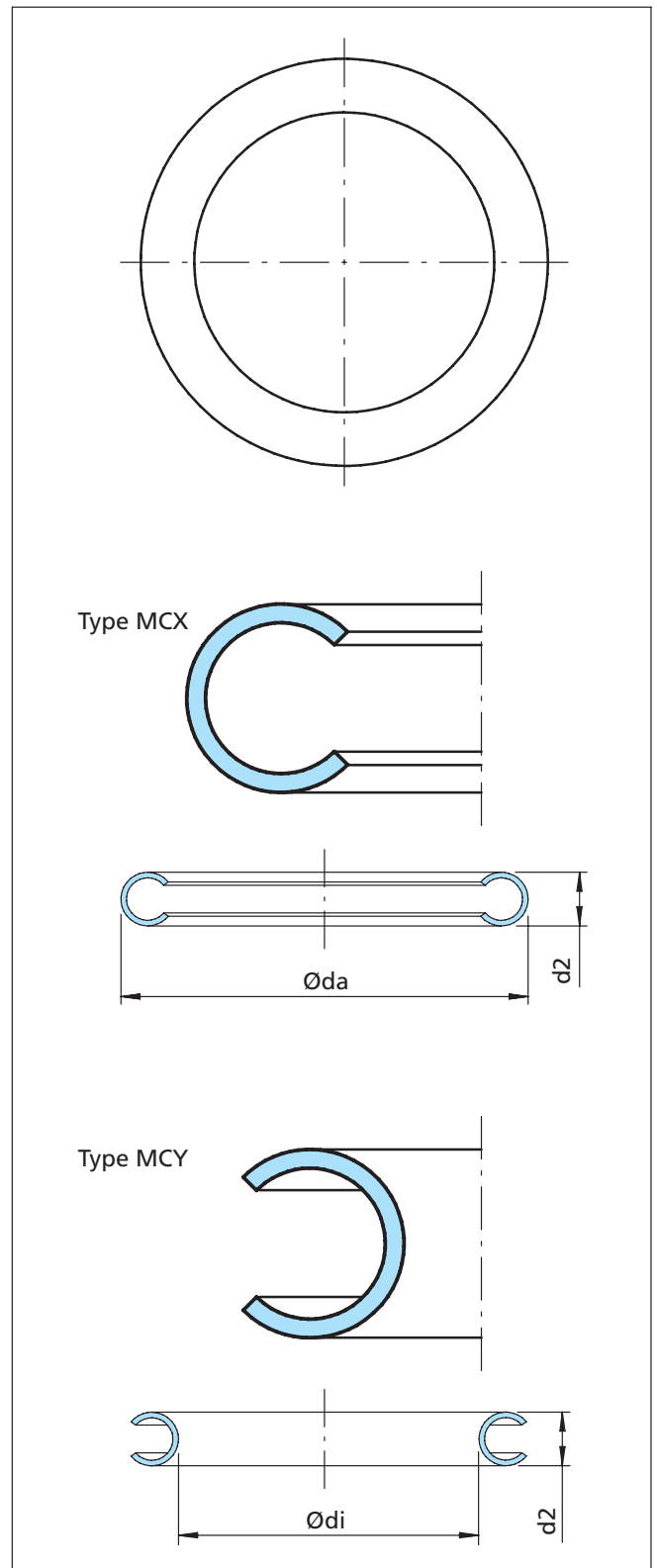

Figure 9 Wills Rings® C - Type MCX/MCY



■ Size Ranges and Free Heights in Metric

Wills Rings® are available in a comprehensive range of sizes. The free height ranges from 0.89 mm to 9.53 mm. For each size there is a range of seal diameters which can be produced. The free height sizes are industry standard and have evolved from inch sizes. See Tables VII and VIII.

Table VII Diameter Size Range for Wills Rings® O

Free Height d2 mm	Wall Code	Wall Thickness mm	Seal Ø da mm	Total Groove Depth ¹⁾ h mm	Groove Width ²⁾ b4 min. mm
0.89	J	0.15	8-50	0.58 ^{+0.08} ₋₀	1.25
1.59	A	0.36	12-150	1.32 ^{+0.08} ₋₀	2.25
	K	0.25			
2.38	B	0.46	25-500	1.83 ^{+0.08} ₋₀	3.00
	L	0.25	50-500		
3.18	C	0.51	60-1000	2.54 ^{+0.13} ₋₀	4.00
	M	0.25			
3.97	D	0.64	100-1250	3.05 ^{+0.13} ₋₀	5.00
	N	0.25			
4.76	E	0.81	115-1500	3.68 ^{+0.13} ₋₀	6.00
	O	0.25	150-1500		
6.35	F	1.02	125-2000	5.08 ^{+0.13} ₋₀	8.00
	P	0.51			
7.94	G	1.27	500-2500	6.35 ^{+0.13} ₋₀	10.00
	-	-			
9.53	H	1.52	750-3000	7.92 ^{+0.13} ₋₀	12.00
		R			

See page 28 for Size Ranges and Free Heights in Inches.

Table VIII Diameter Size Range for Wills Rings® C

Free Height d2 mm	Wall Code	Wall Thickness mm	Seal Ø da mm	Total Groove Depth ¹⁾ h mm	Groove Width ²⁾ b4 min. mm
-	-	-	-	-	-
1.59	A	0.25	20-150	1.32 ^{+0.08} ₋₀	2.25
	K	0.15			
2.38	B	0.38	25-300	1.83 ^{+0.08} ₋₀	3.00
	L	0.25			
3.18	C	0.51	50-400	2.54 ^{+0.13} ₋₀	4.00
	M	0.38			
3.97	D	0.61	60-500	3.05 ^{+0.13} ₋₀	5.00
	N	0.41			
4.76	E	0.76	95-500	3.68 ^{+0.13} ₋₀	6.00
	O	0.51			
6.35	-	-	115-500	5.08 ^{+0.13} ₋₀	8.00
	P	0.64			

See page 28 for Size Ranges and Free Heights in Inches.

Note: 1) When using a gasket in conjunction with Wills Rings® the groove depth must be modified. Please refer to the section on groove design (and in particular on automotive groove design) - pages 15, 16, (Figures 10, 11, 12 and 13).

2) Groove width given in Table VII and VIII is the minimum. Ideally the groove width b4 = 1.5 x d2.



■ Compression Loads to Seat Wills Rings®

When Wills Rings® are located in a housing, a specific load must be applied to the flanges to “seat” the seals correctly. “Seating” the seal is the process of compressing it to the correct depth, such that it forms an effective seal. The seating load can be calculated for each seal. The required seating load must be exceeded by the system used to secure the sealing flanges together.

The system pressure for internal pressure systems also has an effect on the clamping forces. This pressure acts on an area inside the seal diameter causing an extra load on the clamping system.

Minimum seating load required:

$$L_T = L_1 + L_2$$

Where L_T = Total required seating load
 L_1 = Load to seat seal
 L_2 = Load caused by internal system pressure

The securing system must be sufficiently strong to withstand the pressure and temperature effects during the system operation. Most Wills Rings® are available in standard and thin wall sections. Generally, standard wall seals should be used wherever possible. A standard wall thickness ring is stronger and forms a more effective seal. A thin wall seal should be used to provide lower seating loads if required.

Factors affecting the system design and the seating load of a seal are:

- The bolts/clamping system must be sufficient to seat Wills Rings® and withstand the system pressure.
- The system flanges must be strong enough to avoid deformation.
- Loss of bolt strength at elevated temperatures.
- Increases in pressure at elevated temperatures.
- Creep losses/relaxation over time.

Note: Wills Rings®C can be hardened to modify the seal resilience. The seating load figures (given in Tables XII & XIII) are for standard treatment seals only (Code Number 2 - short cycle age hardened). If a non-standard seal treatment is used (see Table IX for options), then the correct Material Factor must be used in the seating load calculation - see Table XI.

All figures given for seating loads are typical values only.

It is recommended that seal users apply an appropriate safety margin in all calculations for the seating loads relative to the sealing requirements.

Tests should be conducted to establish suitability of the clamping system.

Table IX Wills Rings®C Material Conditions

Code	Standard	Treatment
1	No	Work harden
2	Yes	Age harden (short cycle)
3	No	Age harden (long cycle)
4	No	Solution anneal and age harden
5	No	Heat treat to NACE MR0175

Hardness/Seal Resilience

Work hardened seals have lower resilience. This can be adequate for PTFE coated Wills Rings®C. This should be used after consulting your Trelleborg Sealing Solutions representative.

Age hardened Wills Rings®C have higher seal resilience. This is required for silver coated Wills Rings®C.

Age harden (short cycle) is adequate for normal sealing.

Age harden (long cycle) can be used to provide higher seating loads. This will provide greater seal resilience to assist sealing in extreme conditions.

The hardness treatment code **must** be included in the Wills Rings®C part number. See the order example page 27.



■ Calculating Seating Loads

The compressive load required to correctly seat specific Wills Rings® in the recommended groove depends on the seal diameter, seal free height, wall thickness and seal material according to the following expression:

$$L_1 = M \times K \times D_m \times \Pi$$

- where
- L_1 = Load to seat the seal (N)
 - M = Material factor see Table X or XI
 - K = Load in N/mm seal circumference see Table XII or XIII
 - D_m = Median (sealing) diameter of the seal, $d_a - d_2$ (mm)
 - Π = Pythagoras constant (3.142)

Table X Material Factor Wills Rings® O

Material Factor	M
Stainless steel AISI 316L (1.4435)	1.00
Stainless steel AISI 321 (1.4541)	1.00
Inconel® 600	1.10
Mild steel	0.75
Copper	0.50

Table XI Material Factor Wills Rings® C Condition

Material Factor	M
Inconel® X750	1.00
Inconel® 718	1.15

Note: use M x 0.75 for work harden
use M x 1.20 for age harden (long cycle)

Table XII Compressive Load for Standard Wall Wills Rings®

Seal Free Height	Size Code	Wills Rings®		Wall Thickness	Typical Seating Load per Length Circumference N/mm	
d2 mm				mm	K	
0.89	-	-	-	-	-	-
1.59	A	O	-	0.36	275	-
		-	C	0.25	-	110
2.38	B	O	-	0.46	248	-
		-	C	0.38	-	150
3.18	C	O	-	0.51	175	-
		-	C	0.51	-	165
3.97	D	O	-	0.64	162	-
		-	C	0.61	-	180
4.76	E	O	-	0.81	230	-
		-	C	0.76	-	190
6.35	F	O	-	1.02	270	-
7.94	G	O	-	1.27	330	-
9.53	H	O	-	1.52	380	-

Table XIII Compressive Load for Thin Wall Wills Rings®

Seal Free Height	Size Code	Wills Rings®		Wall Thickness	Typical Seating Load per Length Circumference N/mm	
d2 mm				mm	K	
0.89	J	O	-	0.15	100	-
1.59	K	O	-	0.25	125	-
		-	C	0.15	-	95
2.38	L	O	-	0.25	92	-
		-	C	0.25	-	90
3.18	M	O	-	0.25	58	-
		-	C	0.38	-	92
3.97	N	O	-	0.25	29	-
		-	C	0.41	-	58
4.76	O	O	-	0.25	22	-
		-	C	0.51	-	83
6.35	P	O	-	0.51	52	-
		-	C	0.64	-	85
9.53	R	O	-	0.51	85	-



■ Groove Designs

Common Groove

There are several types of groove which may be employed to house Wills Rings® depending upon application and the system requirements (Figure 10).

10.1 Closed groove

The seal is enclosed on its inside and outside diameters.

10.2 Open groove

The seal is enclosed by a groove wall opposing the pressure direction (that is, for internal pressure - the groove wall is on the outside of the seal etc.)

10.3 Retainer plate

If no groove can be constructed, then a plate of equal depth to the groove can be used to provide support to the seal.

10.4 Seal carrier

Can be used where deep grooves need to be sealed.

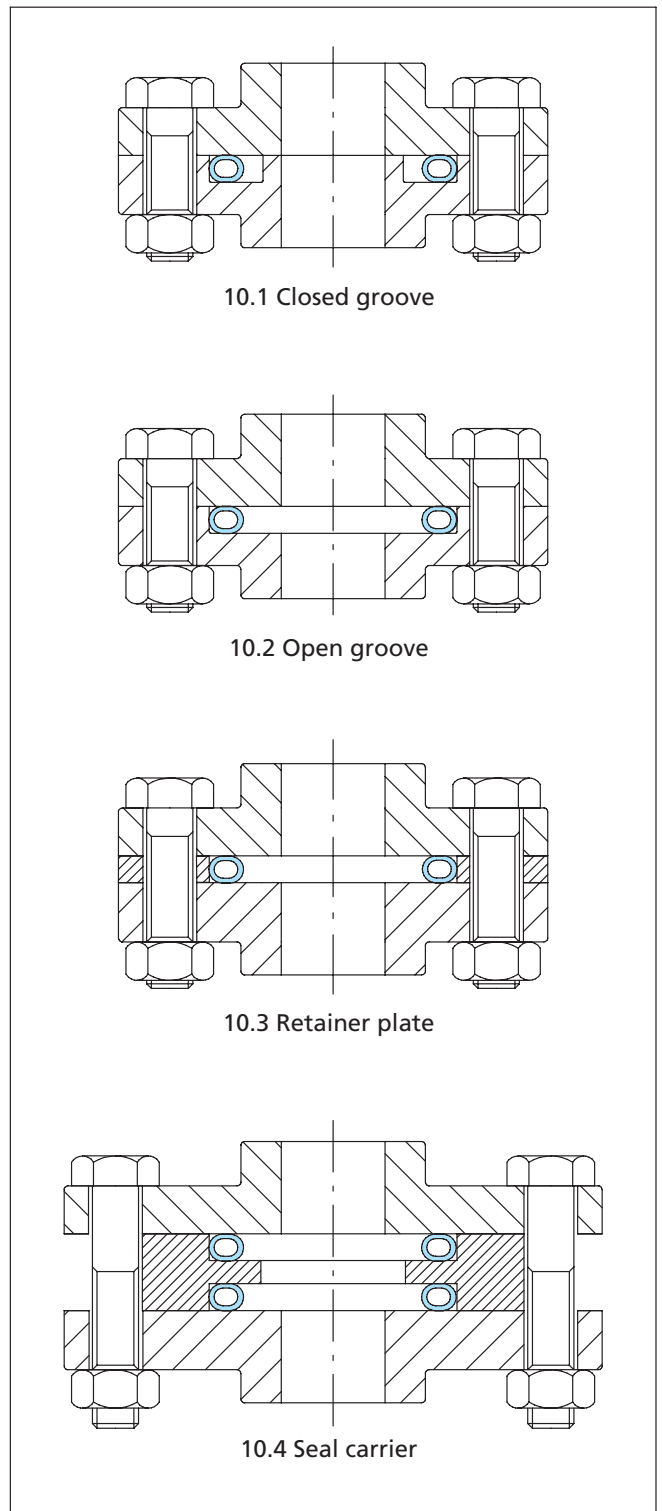

Figure 10 Common installation configuration for Wills Rings® O

All installations above show Wills Rings® O installations.

The same housings can be used for Wills Rings® C installations (see comments about automotive groove).



Automotive Groove*

Another useful method of seal housing is using the automotive groove approach. This seal housing is commonly used for high performance engines to seal the cylinder head to the engine block. Typically Wills Rings® O gas filled seals are used here. Where cyclic engine pressures are found, this groove securely holds the Wills Rings® in place. Also the trapped volume of a closed groove is eliminated.

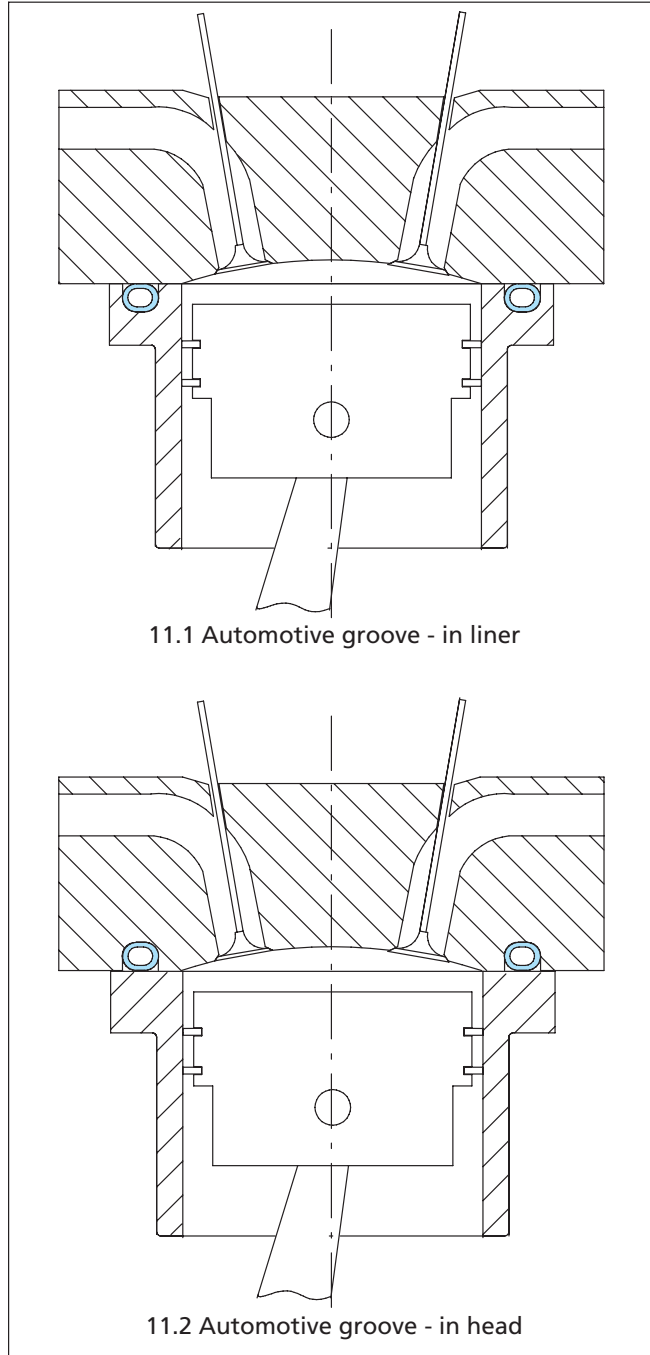

Figure 11 Common automotive installation configuration for Wills Rings® O

The housing has a clearance with the seal inside and outside diameters. The groove has a curved base (Figure 12).

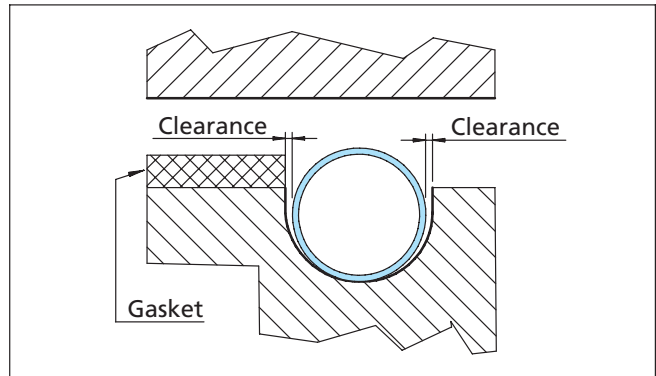

Figure 12 Detail of an automotive groove

Consequently it is held very securely and is protected from the media. This housing groove is preferred for extreme cyclic pressures.

The groove depth given for each free height d_2 is the total compressed depth of Wills Rings® when installed. If an additional form of sealing is to be used (e.g.a gasket), then the machined depth of the housing groove must be less.

$$h = M_d + G_d$$

Where h = Groove depth (overall)
 M_d = Machined depth
 G_d = Crushed gasket depth

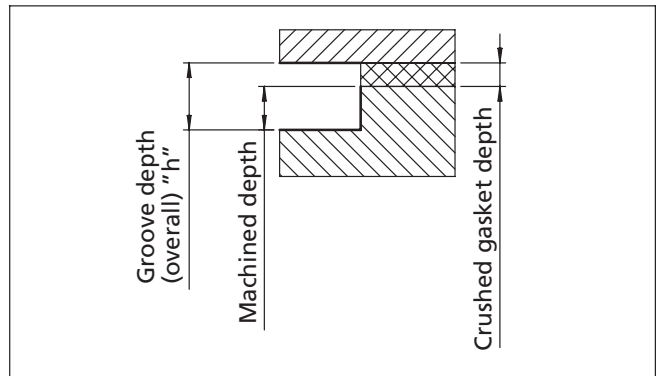

Figure 13 Wills Rings® groove depth with a gasket

* For dimensions for Automotive Grooves please contact your Trelleborg Sealing Solutions representative.



■ Installation Recommendations for Internal Pressure Sealing

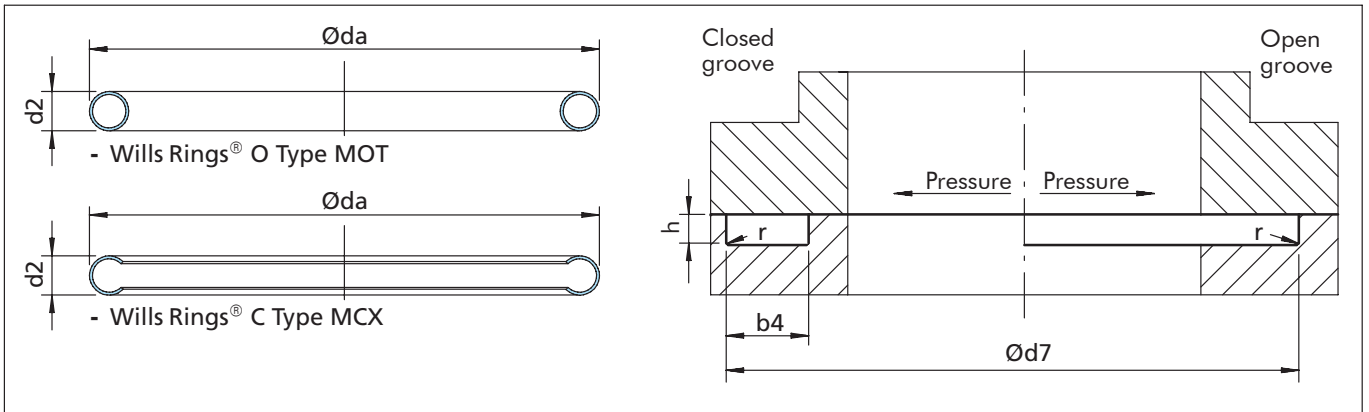

Figure 14 Installation drawing for internal pressure

Table XIV Installation Dimensions for Internal Pressure 4)

Free Height d2 mm	Wills Rings® O Free Height Mat. Codes		Wills Rings® C Free Height Mat. Codes		Groove Depth h	Groove Width 1) b4 min.	Wills Rings® O 2) Øda	Groove Diameter d7, unplated only 3)		Radius r _{max} mm	Wills Rings® Springback	
	Stand.	Thin	Stand.	Thin				= da + clearance + Tolerance			O only	C only
0.89		J	-		0.58 ^{+0.08} / ₀	1.25	8-50	da + 0.10	+0.05	0.25	0.01	-
1.59		K		K	1.32 ^{+0.08} / ₀	2.25	12-150	da + 0.10	+0.05	0.40	0.02	0.10
	A		A									
2.38		L		L	1.83 ^{+0.08} / ₀	3.00	25-500	da + 0.18	+0.12	0.50	0.03	0.10
	B		B									
3.18		M		M	2.54 ^{+0.13} / ₀	4.00	60-1000	da + 0.18	+0.12	0.75	0.03	0.20
	C		C									
3.97		N		N	3.05 ^{+0.13} / ₀	5.00	100-1250	da + 0.18	+0.12	1.25	0.05	0.25
	D		D									
4.76		O		O	3.68 ^{+0.13} / ₀	6.00	115-1500	da + 0.25	+0.12	1.50	0.06	0.25
	E		E									
6.35		P		P	5.08 ^{+0.13} / ₀	8.00	125-2000	da + 0.25	+0.12	1.50	0.07	0.25
	F		-									
7.94	G		-		6.35 ^{+0.13} / ₀	10.00	500-2500	da + 0.38	+0.12	1.50	0.08	-
9.53		R		R	7.92 ^{+0.13} / ₀	12.00	750-3000	da + 0.38	+0.12	1.50	0.09	-
	H		-									

Notes: 1) Minimum value. Recommended is groove width 1.5 x d2.

2) For Wills Rings® C diameter size ranges see page 12 (Table VIII).

3) Calculate exact groove/seal Ø by the expression:

$$d7 = da + (2 \times \text{maximum coating thickness}) + \text{clearance (+ tol.)}$$

$$= da + \text{CTCV page 18 (Table XV, for clearance tolerance correction value)}$$

for example: for a 3.18 mm Wills Rings® C with 3 layers of plating

$$d7 = da + (2 \times 3 \text{ layer coating} = 2 \times 0.085 \text{ mm} = 0.170 \text{ mm}) + \text{clearance (+ tol.)}$$

$$= da + 0.170 + \text{clearance (+ tol.)}$$

$$= da + 0.170 + 0.18 (+0.12)$$

$$= da + 0.47 \text{ mm}$$

4) Excluding Automotive Grooves



■ Clearance Tolerance Correction Values in Metric

How to size the seal for a given groove diameter (or vice versa)

Table XV Clearance - Tolerance Correction Value in mm

	No Plating		1 Layer		2 Layers		3 Layers	
Max. Plating	0.00		+ 0.035		+ 0.060		+ 0.085	
2 x max. Plating	0.00		+ 0.070		+ 0.120		+ 0.170	
Free Height	Total		Total		Total		Total	
0.89 1.59	0.10+0.05 0.10+0.05	0.15	0.17+0.05 0.17+0.05	0.22	0.22+0.05 0.22+0.05	0.27	0.27+0.05 0.27+0.05	0.32
2.38 3.18 3.97	0.18+0.12 0.18+0.12 0.18+0.12	0.30	0.25+0.12 0.25+0.12 0.25+0.12	0.37	0.30+0.12 0.30+0.12 0.30+0.12	0.42	0.35+0.12 0.35+0.12 0.35+0.12	0.47
4.76 6.35	0.25+0.12 0.25+0.12	0.37	0.32+0.12 0.32+0.12	0.44	0.37+0.12 0.37+0.12	0.49	0.42+0.12 0.42+0.12	0.54
7.94 9.53	0.38+0.12 0.38+0.12	0.50	0.45+0.12 0.45+0.12	0.57	0.50+0.12 0.50+0.12	0.62	0.55+0.12 0.55+0.12	0.67

Wills Rings® clearance and tolerance correction values (CTCV) for different plating levels for each free height size.

See page 29 for Clearance Tolerance Correction Values in Inches.

Internal pressure $\varnothing d7 = \varnothing da + \text{CTCV}$

External pressure $\varnothing d8 = \varnothing di - \text{CTCV}$

Note:

Use $\varnothing da$ for Wills Rings® O for external pressure

Use $\varnothing di$ for Wills Rings® C for external pressure

For example

MOT O G1500-1HS

This is a 4.76 mm gas filled Wills Rings® O thin wall seal for a 150.0 mm groove diameter d7. It has silver plate at 3 layers, 0.075/0.085 mm thickness.

The seal diameter is found from $\varnothing d7 = \varnothing da + \text{CTCV}$

$$\begin{aligned} \text{Hence } \varnothing da &= \varnothing d7 - \text{CTCV} \\ &= 150.0 - 0.54 \\ \varnothing da &= 149.46 \text{ mm} \end{aligned}$$



■ Wills Rings® O for Internal Pressure

These are typical of seal part numbers which can be ordered using the groove diameter. Other sizes, materials or finishes may be ordered by referring to the order example, pages 23 to 25 and the seal data. See also page 6 (Tables II and IV).

Table XVI Preferred Sizes Wills Rings® O, metric

Groove Ød7 H9	Seal Non-plated	Seal 1 Layer	Seal 3 Layers	Minimum Groove Width b4	Groove Depth h
10.0	MOT J G0100-1H	MOT J G0100-1HR	MOT J G0100-1HS	1.25	0.58/0.66
12.0	MOT J G0120-1H	MOT J G0120-1HR	MOT J G0120-1HS	1.25	0.58/0.66
15.0	MOT A G0150-1H	MOT A G0150-1HR	MOT A G0150-1HS	2.25	1.32/1.40
20.0	MOT A G0200-1H	MOT A G0200-1HR	MOT A G0200-1HS	2.25	1.32/1.40
25.0	MOT A G0250-1H	MOT A G0250-1HR	MOT A G0250-1HS	2.25	1.32/1.40
30.0	MOT B G0300-1H	MOT B G0300-1HR	MOT B G0300-1HS	3.00	1.83/1.91
35.0	MOT B G0350-1H	MOT B G0350-1HR	MOT B G0350-1HS	3.00	1.83/1.91
40.0	MOT B G0400-1H	MOT B G0400-1HR	MOT B G0400-1HS	3.00	1.83/1.91
45.0	MOT B G0450-1H	MOT B G0450-1HR	MOT B G0450-1HS	3.00	1.83/1.91
50.0	MOT B G0500-1H	MOT B G0500-1HR	MOT B G0500-1HS	3.00	1.83/1.91
55.0	MOT B G0550-1H	MOT B G0550-1HR	MOT B G0550-1HS	3.00	1.83/1.91
60.0	MOT B G0600-1H	MOT B G0600-1HR	MOT B G0600-1HS	3.00	1.83/1.91
65.0	MOT C G0650-1H	MOT C G0650-1HR	MOT C G0650-1HS	4.00	2.54/2.67
70.0	MOT C G0700-1H	MOT C G0700-1HR	MOT C G0700-1HS	4.00	2.54/2.67
75.0	MOT C G0750-1H	MOT C G0750-1HR	MOT C G0750-1HS	4.00	2.54/2.67
80.0	MOT C G0800-1H	MOT C G0800-1HR	MOT C G0800-1HS	4.00	2.54/2.67
85.0	MOT C G0850-1H	MOT C G0850-1HR	MOT C G0850-1HS	4.00	2.54/2.67
90.0	MOT C G0900-1H	MOT C G0900-1HR	MOT C G0900-1HS	4.00	2.54/2.67
95.0	MOT C G0950-1H	MOT C G0950-1HR	MOT C G0950-1HS	4.00	2.54/2.67
100.0	MOT C G1000-1H	MOT C G1000-1HR	MOT C G1000-1HS	4.00	2.54/2.67
110.0	MOT D G1100-1H	MOT D G1100-1HR	MOT D G1100-1HS	5.00	3.05/3.18
120.0	MOT D G1200-1H	MOT D G1200-1HR	MOT D G1200-1HS	5.00	3.05/3.18
130.0	MOT D G1300-1H	MOT D G1300-1HR	MOT D G1300-1HS	5.00	3.05/3.18
140.0	MOT D G1400-1H	MOT D G1400-1HR	MOT D G1400-1HS	5.00	3.05/3.18
150.0	MOT D G1500-1H	MOT D G1500-1HR	MOT D G1500-1HS	5.00	3.05/3.18
160.0	MOT D G1600-1H	MOT D G1600-1HR	MOT D G1600-1HS	5.00	3.05/3.18
170.0	MOT E G1700-1H	MOT E G1700-1HR	MOT E G1700-1HS	6.00	3.68/3.81
180.0	MOT E G1800-1H	MOT E G1800-1HR	MOT E G1800-1HS	6.00	3.68/3.81
190.0	MOT E G1900-1H	MOT E G1900-1HR	MOT E G1900-1HS	6.00	3.68/3.81
200.0	MOT E G2000-1H	MOT E G2000-1HR	MOT E G2000-1HS	6.00	3.68/3.81
250.0	MOT E G2500-1H	MOT E G2500-1HR	MOT E G2500-1HS	6.00	3.68/3.81
300.0	MOT F G3000-1H	MOT F G3000-1HR	MOT F G3000-1HS	8.00	5.08/5.21
350.0	MOT F G3500-1H	MOT F G3500-1HR	MOT F G3500-1HS	8.00	5.08/5.21
400.0	MOT F G4000-1H	MOT F G4000-1HR	MOT F G4000-1HS	8.00	5.08/5.21
450.0	MOT F G4500-1H	MOT F G4500-1HR	MOT F G4500-1HS	8.00	5.08/5.21
500.0	MOT F G5000-1H	MOT F G5000-1HR	MOT F G5000-1HS	8.00	5.08/5.21

Use this selection when designing a new housing/sealing system. Also applies to Wills Rings® O for Type MOV/MOW, MOS & MOU.

Note: These seal part numbers use the groove Ø (indicated by "G" in the Ø code). This is not equal to the seal Ø. The seal Ø has a clearance fit depending upon the plating used. See the Clearance - Tolerance Correction Value (Table XV, page 18). The diameter shown is multiplied by a factor of 10 for groove dimensioned seals.



■ Wills Rings® C for Internal Pressure

These are typical of seal part numbers which can be ordered using the groove diameter. Other sizes, materials or finishes may be ordered by referring to the order example, pages 26 to 27 and the seal data. See also page 6 (Tables III and IV).

Table XVII Preferred Sizes Wills Rings® C, metric

Groove Ød7 H9	Seal 1 Layer	Seal 2 Layers	Seal 3 Layers	Minimum Groove Width b4	Groove Depth h
20.0	MCX A G0200-1NR2	MCX A G0200-1NU2	MCX A G0200-1NS2	2.25	1.32/1.40
25.0	MCX A G0250-1NR2	MCX A G0250-1NU2	MCX A G0250-1NS2	2.25	1.32/1.40
30.0	MCX A G0300-1NR2	MCX A G0300-1NU2	MCX A G0300-1NS2	2.25	1.32/1.40
35.0	MCX A G0350-1NR2	MCX A G0350-1NU2	MCX A G0350-1NS2	2.25	1.32/1.40
40.0	MCX A G0400-1NR2	MCX A G0400-1NU2	MCX A G0400-1NS2	2.25	1.32/1.40
50.0	MCX A G0500-1NR2	MCX A G0500-1NU2	MCX A G0500-1NS2	2.25	1.32/1.40
30.0	MCX B G0300-1NR2	MCX B G0300-1NU2	MCX B G0300-1NS2	3.00	1.83/1.91
40.0	MCX B G0400-1NR2	MCX B G0400-1NU2	MCX B G0400-1NS2	3.00	1.83/1.91
50.0	MCX B G0500-1NR2	MCX B G0500-1NU2	MCX B G0500-1NS2	3.00	1.83/1.91
60.0	MCX B G0600-1NR2	MCX B G0600-1NU2	MCX B G0600-1NS2	3.00	1.83/1.91
70.0	MCX B G0700-1NR2	MCX B G0700-1NU2	MCX B G0700-1NS2	3.00	1.83/1.91
80.0	MCX B G0800-1NR2	MCX B G0800-1NU2	MCX B G0800-1NS2	3.00	1.83/1.91
90.0	MCX B G0900-1NR2	MCX B G0900-1NU2	MCX B G0900-1NS2	3.00	1.83/1.91
70.0	MCX C G0700-1NR2	MCX C G0700-1NU2	MCX C G0700-1NS2	4.00	2.54/2.67
80.0	MCX C G0800-1NR2	MCX C G0800-1NU2	MCX C G0800-1NS2	4.00	2.54/2.67
90.0	MCX C G0900-1NR2	MCX C G0900-1NU2	MCX C G0900-1NS2	4.00	2.54/2.67
100.0	MCX C G1000-1NR2	MCX C G1000-1NU2	MCX C G1000-1NS2	4.00	2.54/2.67
110.0	MCX C G1100-1NR2	MCX C G1100-1NU2	MCX C G1100-1NS2	4.00	2.54/2.67
150.0	MCX C G1500-1NR2	MCX C G1500-1NU2	MCX C G1500-1NS2	4.00	2.54/2.67
110.0	MCX D G1100-1NR2	MCX D G1100-1NU2	MCX D G1100-1NS2	5.00	3.05/3.18
120.0	MCX D G1200-1NR2	MCX D G1200-1NU2	MCX D G1200-1NS2	5.00	3.05/3.18
130.0	MCX D G1300-1NR2	MCX D G1300-1NU2	MCX D G1300-1NS2	5.00	3.05/3.18
140.0	MCX D G1400-1NR2	MCX D G1400-1NU2	MCX D G1400-1NS2	5.00	3.05/3.18
150.0	MCX D G1500-1NR2	MCX D G1500-1NU2	MCX D G1500-1NS2	5.00	3.05/3.18
160.0	MCX D G1600-1NR2	MCX D G1600-1NU2	MCX D G1600-1NS2	5.00	3.05/3.18
160.0	MCX E G1600-1NR2	MCX E G1600-1NU2	MCX E G1600-1NS2	6.00	3.68/3.81
170.0	MCX E G1700-1NR2	MCX E G1700-1NU2	MCX E G1700-1NS2	6.00	3.68/3.81
180.0	MCX E G1800-1NR2	MCX E G1800-1NU2	MCX E G1800-1NS2	6.00	3.68/3.81
190.0	MCX E G1900-1NR2	MCX E G1900-1NU2	MCX E G1900-1NS2	6.00	3.68/3.81
200.0	MCX E G2000-1NR2	MCX E G2000-1NU2	MCX E G2000-1NS2	6.00	3.68/3.81
160.0	MCX P G1600-1NR2	MCX P G1600-1NU2	MCX P G1600-1NS2	8.00	5.08/5.21
170.0	MCX P G1700-1NR2	MCX P G1700-1NU2	MCX P G1700-1NS2	8.00	5.08/5.21
180.0	MCX P G1800-1NR2	MCX P G1800-1NU2	MCX P G1800-1NS2	8.00	5.08/5.21
190.0	MCX P G1900-1NR2	MCX P G1900-1NU2	MCX P G1900-1NS2	8.00	5.08/5.21
200.0	MCX P G2000-1NR2	MCX P G2000-1NU2	MCX P G2000-1NS2	8.00	5.08/5.21

Use this selection when designing a new housing/sealing system.

Note: These seal part numbers use the groove Ø (indicated by "G" in the Ø code). This is not equal to the seal Ø. The seal Ø has a clearance fit depending upon the plating used. See the Clearance - Tolerance Correction Value (Table XV page 18).

The diameter shown is multiplied by a factor of 10 for groove dimensioned seals.



■ Installation Recommendations for External Pressure Sealing

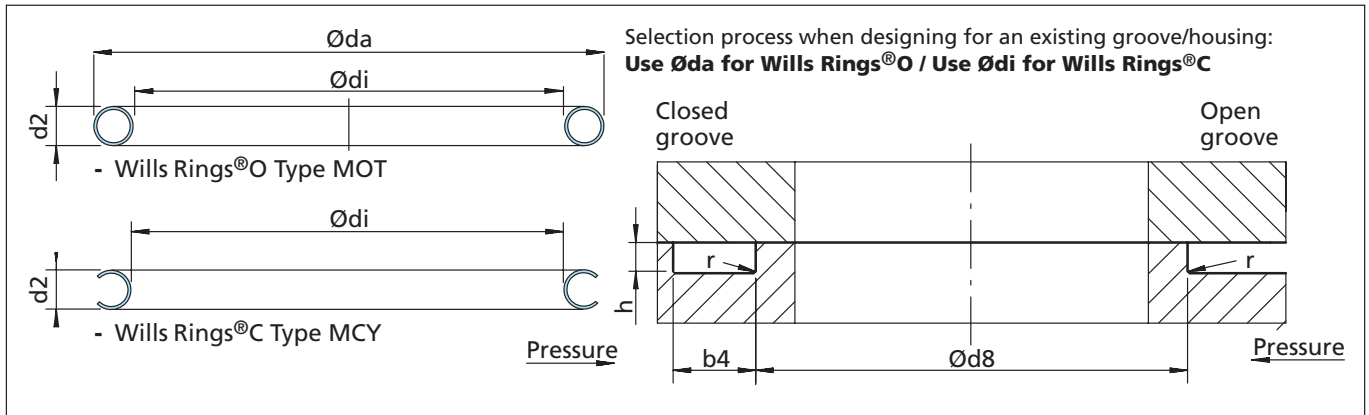

Figure 15 Installation drawing for external pressure

Table XVIII Installation Dimensions for External Pressure 4)

Free Height d2 mm	Wills Rings® O Free Height Mat. Codes		Wills Rings® C Free Height Mat. Codes		Groove Depth h	Groove Width 1) b4 min.	Wills Rings® O 2) Øda	Groove Diameter d8, unplated only 3)		Radius r _{max} mm	Wills Rings® Springback	
	Stand	Thin	Stand	Thin				= di - clearance - tolerance			O only	C only
0.89		J	-		0.58 ^{+0.08} / ₀	1.25	8-50	di - 0.10	-0.05	0.25	0.01	-
1.59		K		K	1.32 ^{+0.08} / ₀	2.25	12-150	di - 0.10	-0.05	0.40	0.02	0.10
	A		A									
2.38		L		L	1.83 ^{+0.08} / ₀	3.00	25-500	di - 0.18	-0.12	0.50	0.03	0.10
	B		B									
3.18		M		M	2.54 ^{+0.13} / ₀	4.00	60-1000	di - 0.18	-0.12	0.75	0.03	0.20
	C		C									
3.97		N		N	3.05 ^{+0.13} / ₀	5.00	100-1250	di - 0.18	-0.12	1.25	0.05	0.25
	D		D									
4.76		O		O	3.68 ^{+0.13} / ₀	6.00	115-1500	di - 0.25	-0.12	1.50	0.06	0.25
	E		E									
6.35		P		P	5.08 ^{+0.13} / ₀	8.00	125-2000	di - 0.25	-0.12	1.50	0.07	0.25
	F		-									
7.94	G		-		6.35 ^{+0.13} / ₀	10.00	500-2500	di - 0.38	-0.12	1.50	0.08	-
9.53		R		-	7.92 ^{+0.13} / ₀	12.00	750-3000	di - 0.38	-0.12	1.50	0.09	-
	H		-									

- Notes: 1) Minimum value. Recommended is groove width 1.5 x d2.
 2) For Wills Rings®C diameter size ranges see page 12 (Table VIII).
 3) Calculate exact groove/seal Ø by the expression:
 $d8 = di - (2 \times \text{maximum coating thickness}) - \text{clearance} (- \text{tol.})$
 $d8 = di - \text{CTCV}$ (page 18 Table XV, for clearance tolerance correction value)

for example: for a 2.38 mm Wills Rings®O with 1 layer of plating
 $d8 = di - (2 \times 1 \text{ layer coating} = 2 \times 0.035 \text{ mm} = 0.070 \text{ mm}) - \text{clearance} (- \text{tol.})$
 $= di - 0.070 - \text{clearance} (- \text{tol.})$
 $= di - 0.070 - 0.18 (-0.12)$
 $= di - 0.37 \text{ mm}$

4) Excluding Automotive Grooves



■ Wills Rings® C for External Pressure

These are typical of seal part numbers which can be ordered using the groove diameter. Other sizes, materials or finishes may be ordered by referring to the order example, pages 26 to 27 and the seal data. See also page 6 (Tables III and IV).

Table XIX Preferred Sizes Wills Rings® C, metric

Groove Ød8 h9	Seal 1 Layer	Seal 2 Layers	Seal 3 Layers	Minimum Groove Width b4	Groove Depth h
20.0	MCY A G0200-1NR2	MCY A G0200-1NU2	MCY A G0200-1NS2	2.25	1.32/1.40
25.0	MCY A G0250-1NR2	MCY A G0250-1NU2	MCY A G0250-1NS2	2.25	1.32/1.40
30.0	MCY A G0300-1NR2	MCY A G0300-1NU2	MCY A G0300-1NS2	2.25	1.32/1.40
35.0	MCY A G0350-1NR2	MCY A G0350-1NU2	MCY A G0350-1NS2	2.25	1.32/1.40
40.0	MCY A G0400-1NR2	MCY A G0400-1NU2	MCY A G0400-1NS2	2.25	1.32/1.40
50.0	MCY A G0500-1NR2	MCY A G0500-1NU2	MCY A G0500-1NS2	2.25	1.32/1.40
30.0	MCY B G0300-1NR2	MCY B G0300-1NU2	MCY B G0300-1NS2	3.00	1.83/1.91
40.0	MCY B G0400-1NR2	MCY B G0400-1NU2	MCY B G0400-1NS2	3.00	1.83/1.91
50.0	MCY B G0500-1NR2	MCY B G0500-1NU2	MCY B G0500-1NS2	3.00	1.83/1.91
60.0	MCY B G0600-1NR2	MCY B G0600-1NU2	MCY B G0600-1NS2	3.00	1.83/1.91
70.0	MCY B G0700-1NR2	MCY B G0700-1NU2	MCY B G0700-1NS2	3.00	1.83/1.91
80.0	MCY B G0800-1NR2	MCY B G0800-1NU2	MCY B G0800-1NS2	3.00	1.83/1.91
90.0	MCY B G0900-1NR2	MCY B G0900-1NU2	MCY B G0900-1NS2	3.00	1.83/1.91
70.0	MCY C G0700-1NR2	MCY C G0700-1NU2	MCY C G0700-1NS2	4.00	2.54/2.67
80.0	MCY C G0800-1NR2	MCY C G0800-1NU2	MCY C G0800-1NS2	4.00	2.54/2.67
90.0	MCY C G0900-1NR2	MCY C G0900-1NU2	MCY C G0900-1NS2	4.00	2.54/2.67
100.0	MCY C G1000-1NR2	MCY C G1000-1NU2	MCY C G1000-1NS2	4.00	2.54/2.67
110.0	MCY C G1100-1NR2	MCY C G1100-1NU2	MCY C G1100-1NS2	4.00	2.54/2.67
150.0	MCY C G1500-1NR2	MCY C G1500-1NU2	MCY C G1500-1NS2	4.00	2.54/2.67
110.0	MCY D G1100-1NR2	MCY D G1100-1NU2	MCY D G1100-1NS2	5.00	3.05/3.18
120.0	MCY D G1200-1NR2	MCY D G1200-1NU2	MCY D G1200-1NS2	5.00	3.05/3.18
130.0	MCY D G1300-1NR2	MCY D G1300-1NU2	MCY D G1300-1NS2	5.00	3.05/3.18
140.0	MCY D G1400-1NR2	MCY D G1400-1NU2	MCY D G1400-1NS2	5.00	3.05/3.18
150.0	MCY D G1500-1NR2	MCY D G1500-1NU2	MCY D G1500-1NS2	5.00	3.05/3.18
160.0	MCY D G1600-1NR2	MCY D G1600-1NU2	MCY D G1600-1NS2	5.00	3.05/3.18
160.0	MCY E G1600-1NR2	MCY E G1600-1NU2	MCY E G1600-1NS2	6.00	3.68/3.81
170.0	MCY E G1700-1NR2	MCY E G1700-1NU2	MCY E G1700-1NS2	6.00	3.68/3.81
180.0	MCY E G1800-1NR2	MCY E G1800-1NU2	MCY E G1800-1NS2	6.00	3.68/3.81
190.0	MCY E G1900-1NR2	MCY E G1900-1NU2	MCY E G1900-1NS2	6.00	3.68/3.81
200.0	MCY E G2000-1NR2	MCY E G2000-1NU2	MCY E G2000-1NS2	6.00	3.68/3.81
160.0	MCY P G1600-1NR2	MCY P G1600-1NU2	MCY P G1600-1NS2	8.00	5.08/5.21
170.0	MCY P G1700-1NR2	MCY P G1700-1NU2	MCY P G1700-1NS2	8.00	5.08/5.21
180.0	MCY P G1800-1NR2	MCY P G1800-1NU2	MCY P G1800-1NS2	8.00	5.08/5.21
190.0	MCY P G1900-1NR2	MCY P G1900-1NU2	MCY P G1900-1NS2	8.00	5.08/5.21
200.0	MCY P G2000-1NR2	MCY P G2000-1NU2	MCY P G2000-1NS2	8.00	5.08/5.21

Use this selection when designing a new housing/sealing system.

Note: These seal part numbers use the groove Ød8 (indicated by "G" in the part number). This is not equal to the seal Ødi. The seal diameter Ødi is found by using the CTCV as given in Table XV, page 18. The diameter shown in the part number is multiplied by a factor of 10 for groove dimensioned seals.



■ Part Number and Ordering Instructions in Metric

1. Wills Rings® O Internal Pressure (Sealing on the Outside Diameter)

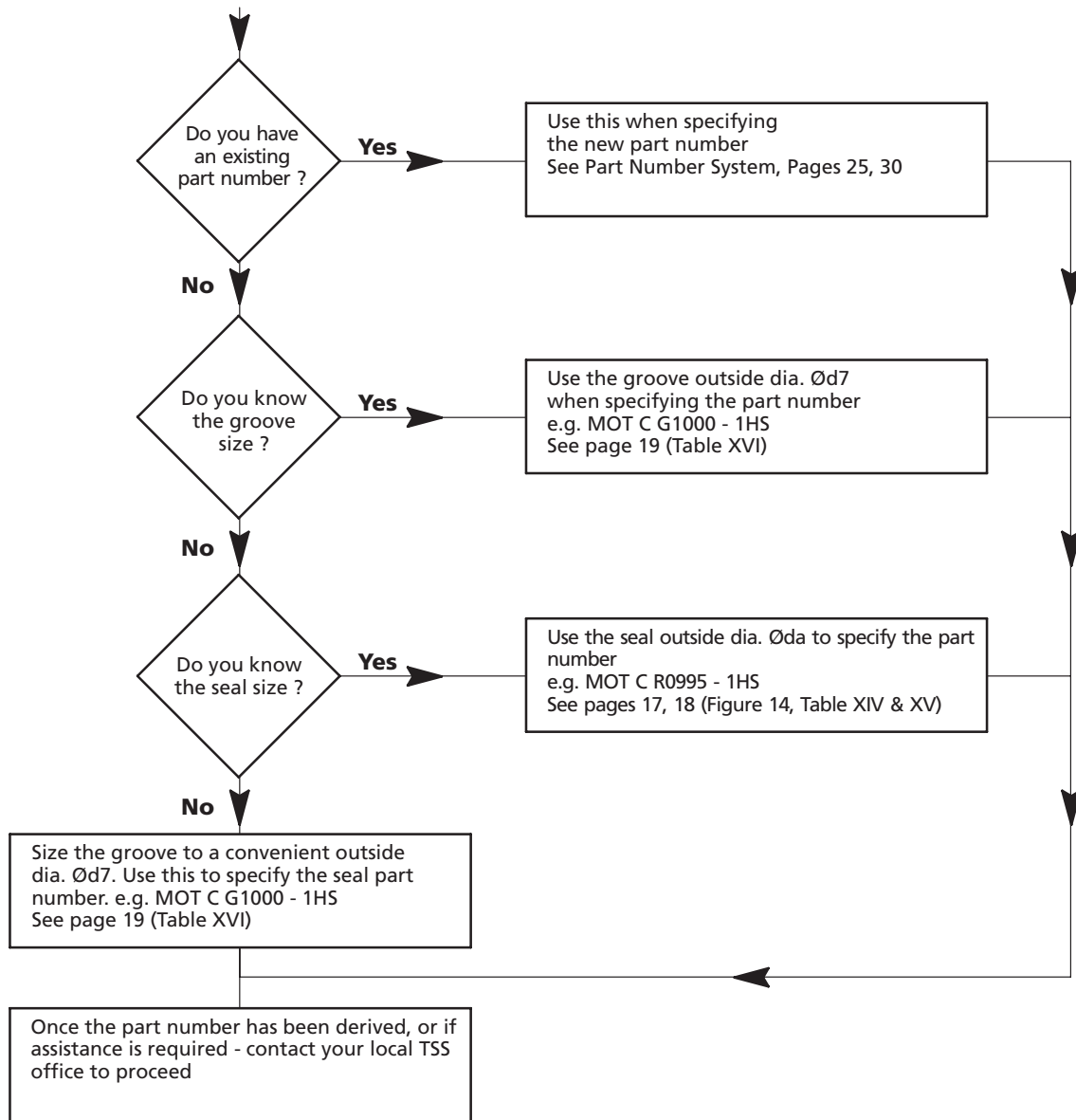

Dimensions are:
 Øda = Seal outside diameter
 Ødi = Seal inside diameter
 Ød7 = Groove outside diameter
 Ød8 = Groove inside diameter
 d2 = Seal free height
 Øda = Ød7 - CTCV
 Ødi = Ød8 + CTCV
 Øda = Ødi + (2 x d2)

Example:
 Groove outside dia. Ød7 = 100.00 mm
 Seal outside dia. Øda = 99.53 mm
 Seal 3.18 mm standard wall 316L stainless steel + 3 layers of silver plate gas filled Wills Rings® O
 Clearance tolerance correction value - see page 18 (Table XV)
 (CTCV) = 0.47 mm

**The TSS part number for this could be:
 MOT C G1000 - 1HS (when based on the groove dia.)
 MOT C R0995 - 1HS (when based on the seal dia.)**



2. Wills Rings® O External Pressure (Sealing on the Inside Diameter)

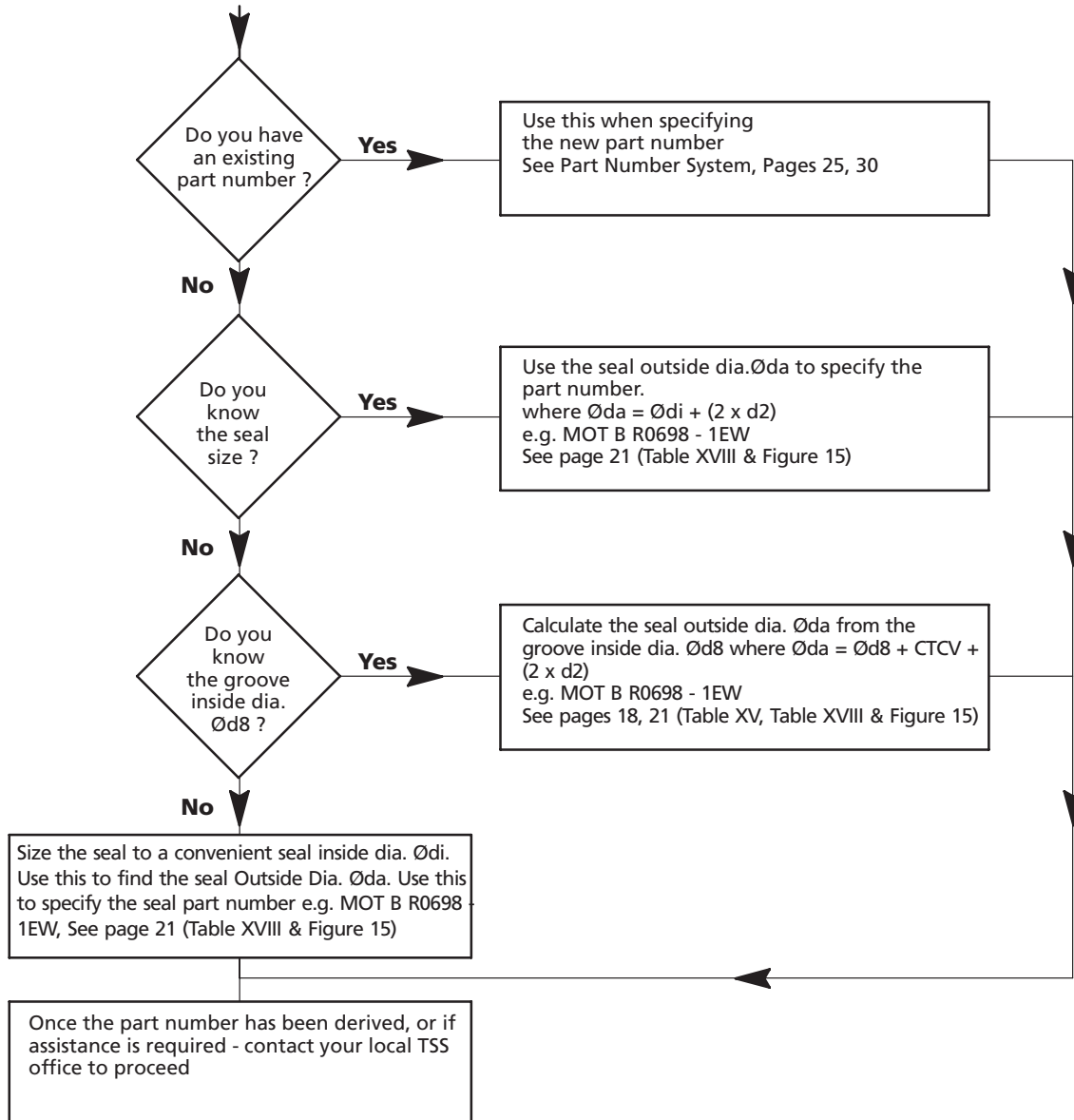

Dimensions are:

- Øda = Seal outside diameter
- Ødi = Seal inside diameter
- Ød7 = Groove outside diameter
- Ød8 = Groove inside diameter
- d2 = Seal free height
- Øda = Ød7 - CTCV
- Ødi = Ød8 + CTCV
- Øda = Ødi + (2 x d2)

Note: For external pressure, seal on groove inside Dia. Ød8, the seal cannot be specified using groove inside Dia. Ød8 for Wills Rings® O. This seal must be specified using the seal outside dia. Øda.

Example:

- Groove inside dia. Ød8 = 64.63 mm
- Seal inside dia. Ødi = 65.00 mm
- Seal outside dia. Øda = 69.76 mm
- Seal free height d2 = 2.38 mm
- Standard wall 321 SS + PTFE coating
- Gas filled Wills Rings® O
- Clearance tolerance correction value (CTCV) = 0.37 mm

**The TSS part number for this is:
MOT B R0698 - 1EW (based on the seal outside dia.)**



Part Number Systems for Wills Rings® in Metric

Table XX Part Number System for Wills Rings® O in Metric

Seal Type	Series	Free Height/ Wall Size mm	Seal Diameter	Quality Characteristic Code	Characteristic Number	Seal Material	Coating Material
M: Metal O: O-Ring profile	S Solid T Gas-filled U Non-pressurized V Pressure vented ID W Pressure vented OD	Standard wall	Diameter x 10 (up to) 999.9 G - - - - this is the groove outside dia. Ød7 x 10 Use the groove method only for internal pressure/ external sealing Alternatively R - - - - this is the ring outside dia. Øda x 10	"- Standard Quality "K" X-Ray required "A" Aerospa ce use	1 = Standard	B Mild steel H Stainless st. AISI 316L (1.4435) E Stainless st. AISI 321 (1.4541) M Inconel® 600 O Copper	W PTFE Q Nickel O Copper I Gold N Indium R Silver 1 layer U Silver 2 layers S Silver 3 layers
		A 1.59 0.36					
		B 2.38 0.46					
		C 3.18 0.51					
		D 3.97 0.64					
		E 4.76 0.81					
		F 6.35 1.02					
		G 7.94 1.27					
		H 9.53 1.52					
		Thin wall					
		J 0.89 0.15					
		K 1.59 0.25					
		L 2.38 0.25					
		M 3.18 0.25					
		N 3.97 0.25					
		O 4.76 0.25					
		P 6.35 0.51					
		R 9.53 0.51					

Note: MOV/MOW (Vented type Wills Rings® O) seal not available in 0.89 mm (0.035") Free Height size J. Use MOT type or increase to a 1.59 mm (0.063") size instead.

Example 1

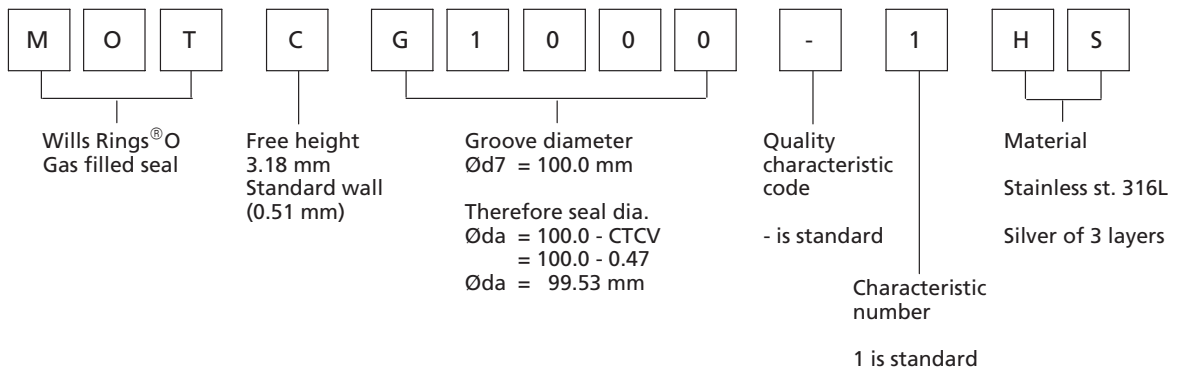

Example 2

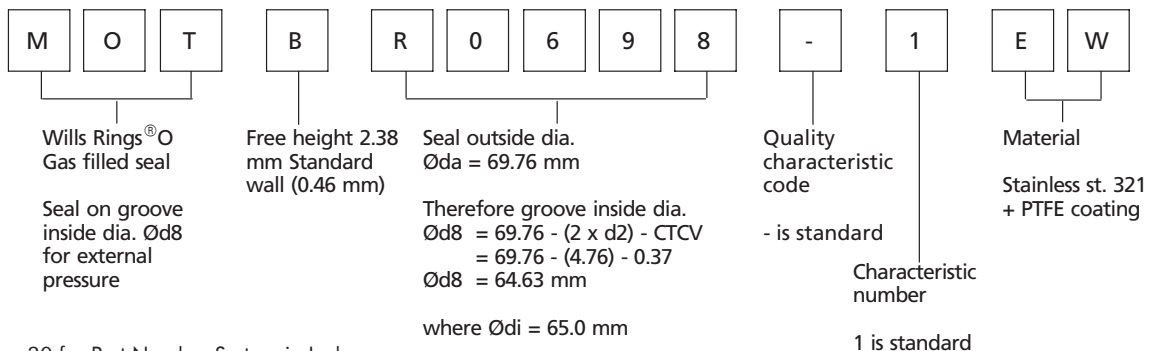

See page 30 for Part Number System in Inches.



3. Wills Rings® C Internal Pressure (Sealing on the Outside Diameter) & External Pressure (Sealing on the Inside Diameter)

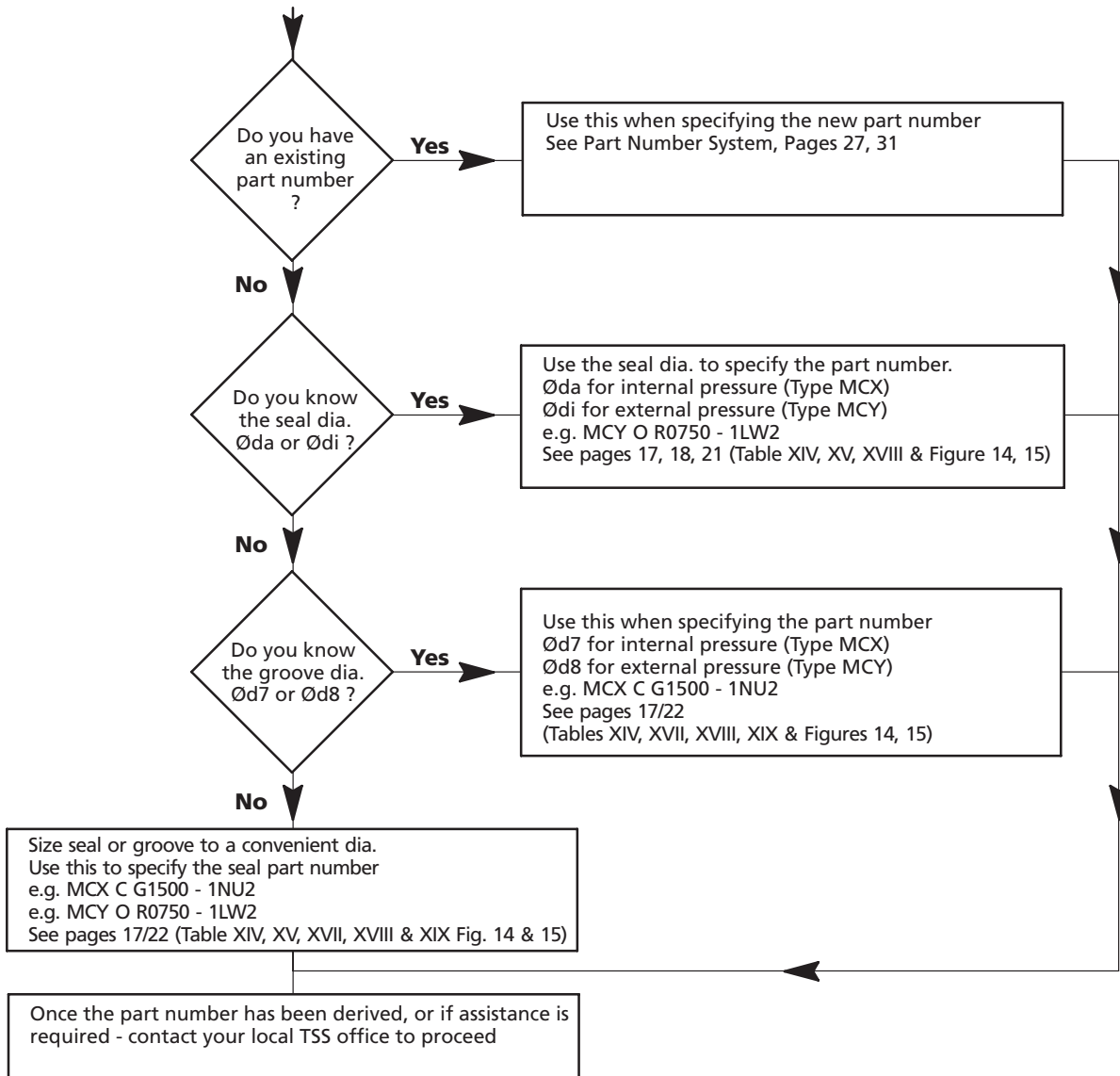

Dimensions are:

- Øda = Seal outside diameter
- Ødi = Seal inside diameter
- Ød7 = Groove outside diameter
- Ød8 = Groove inside diameter
- d2 = Seal free height
- Øda = Ød7 - CTCV
- Ødi = Ød8 + CTCV
- but
- Øda # Ødi + (2 x d2)

Example:

- Seal inside dia. Ødi = 75.00 mm
- Groove inside dia. Ød8 = 74.56 mm
- Seal free height d2 = 4.76 mm
- Thin wall Inconel® 718 + PTFE coating
- External pressure Wills Rings® C type MCY
- Clearance tolerance correction value (CTCV) = 0.44 mm

The TSS part number for this could be:
MCY O R0750-ILW 2 or
MCY O G0746-ILW 2

Note: Type MCX

For internal pressure, sealing on the outside dia. - use the seal outside dia. Øda, or the groove outside dia. Ød7 to size the Wills Rings® C seal.

Type MCY

For external pressure, sealing on the inside dia. - use the seal inside dia. Ødi, or the groove inside dia. Ød8 to size the Wills Rings® C seal.



Table XXI Part Number System for Wills Rings® C in Metric

Seal Type	Series	Free Height/ Wall Size mm	Seal Diameter	Quality Characteristic Code	Charac- teristic Number	Seal Material	Coating Material	Treatment
M: Metal C: C-Ring profile	X Internal pressure Y External pressure	Standard wall	(up to 999.9) G ---- this is the groove dia. (Ød7 or Ød8) x 10	"- " Standard Quality "A" Aerospace use	1=Standard	L Inconel® 718 N Inconel® X750	W PTFE O Copper I Gold N Indium R Silver 1 layer U Silver 2 layers S Silver 3 layers	1 = Work harden 2 = Standard age harden (short cycle) 3 = Age harden (long cycle) 4 = Solution anneal and age harden 5 = Heat treat to NACE MR0175
		Thin wall	R ---- this is the seal dia. (Øda or Ødi) x 10					
		K 1.59 0.15 L 2.38 0.25 M 3.18 0.38 N 3.97 0.41 O 4.76 0.51 P 6.35 0.64						

Example 1

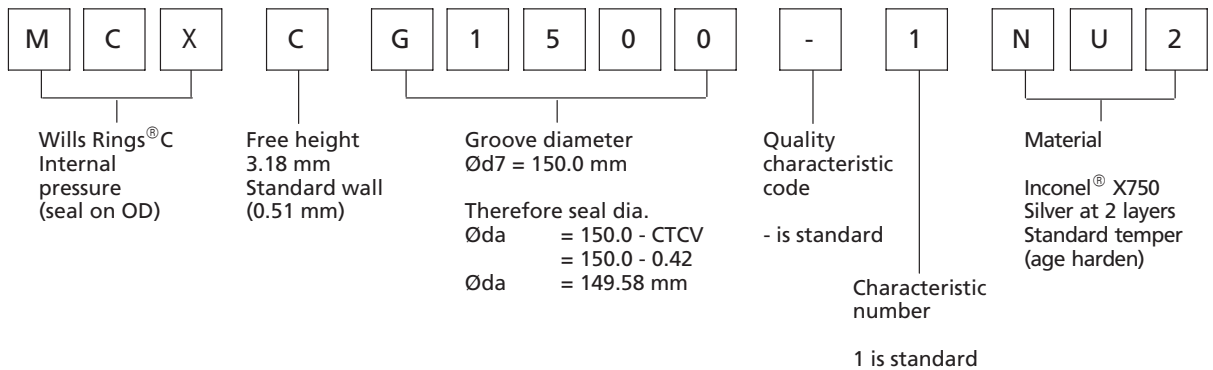

Example 2

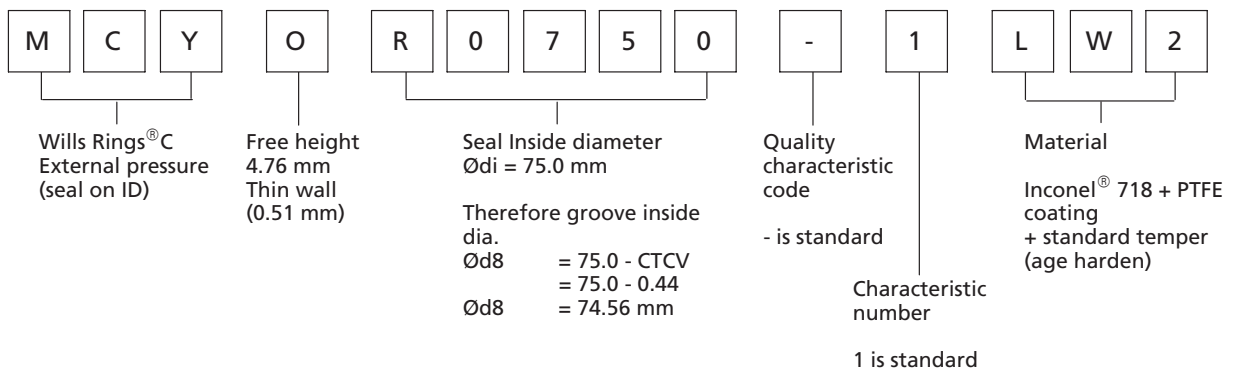

See page 31 for Part Number System in Inches



■ Size Ranges and Free Heights in Inches

This catalogue has mostly been based upon metric dimensions. However, in some markets inches are the preferred units of size. Here follows some tables giving inch nominal equivalents of the Wills Rings® metric sizes.

Wills Rings® are available in a comprehensive range of sizes. The free height ranges from 0.035" to 0.375". For each size there is a range of seal diameters which can be produced.

Table XXII Diameter Size Range in Inches for Wills Rings® O

Free Height d2 inch	Wall Code	Wall inch	Seal Ø da inch	Total Groove Depth ¹⁾ h inch	Groove Width ²⁾ b4 min. inch
0.035	J	0.006	0.313-2	0.023 ^{+0.003} ₋₀	0.050
0.063	A	0.014	0.5-6	0.052 ^{+0.003} ₋₀	0.100
	K	0.010			
0.094	B	0.018	1-20	0.072 ^{+0.003} ₋₀	0.135
	L	0.010	2-20		
0.125	C	0.020	2.5-40	0.100 ^{+0.005} ₋₀	0.200
	M	0.010			
0.156	D	0.025	4-60	0.120 ^{+0.005} ₋₀	0.225
	N	0.010			
0.187	E	0.032	4.5-60	0.145 ^{+0.005} ₋₀	0.250
	O	0.010	6-60		
0.250	F	0.040	5-80	0.200 ^{+0.005} ₋₀	0.350
	P	0.020			
0.313	G	0.050	20-100	0.250 ^{+0.005} ₋₀	0.400
	-	-			
0.375	H	0.060	30-120	0.312 ^{+0.005} ₋₀	0.500
	R	0.020			

See page 12 for Size Ranges and Free Heights in Metric.

Table XXIII Diameter Size Range in Inches for Wills Rings® C

Free Height d2 inch	Wall Code	Wall inch	Seal Ø da inch	Total Groove Depth ¹⁾ h inch	Groove Width ²⁾ b4 min. inch
-	-	-	-	-	-
0.063	A	0.010	0.8-6	0.052 ^{+0.003} ₋₀	0.100
	K	0.006			
0.094	B	0.015	1-12	0.072 ^{+0.003} ₋₀	0.135
	L	0.010			
0.125	C	0.020	2-16	0.100 ^{+0.005} ₋₀	0.200
	M	0.015			
0.156	D	0.024	2.4-20	0.120 ^{+0.005} ₋₀	0.225
	N	0.016			
0.187	E	0.030	3.75-20	0.145 ^{+0.005} ₋₀	0.250
	O	0.020			
0.250	-	-	4.5-20	0.200 ^{+0.005} ₋₀	0.350
	P	0.025			

See page 12 for Size Ranges and Free Heights in Metric.

Note: 1) When using a gasket in conjunction with Wills Rings® the groove depth must be modified. Please refer to the section on groove design (and in particular on automotive groove design) - pages 15, 16, (Figures 10, 11, 12 and 13).

2) Groove width given in Table XXII and XXIII is the minimum. Ideally the groove width b4 = 1.5 x d2.



■ Clearance Tolerance Correction Values in Inches

How to size the seal for a given groove diameter (or vice versa)

Table XXIV Clearance - Tolerance Correction Value in Inches

	No Plating		1 Layer		2 Layers		3 Layers	
Max. Plating	0.00		+ 0.0015		+ 0.0025		+ 0.0035	
2 x max. Plating	0.00		+ 0.003		+ 0.005		+ 0.007	
Free Height	Total		Total		Total		Total	
0.035 0.063	0.004+0.002 0.004+0.002	0.006	0.007+0.002 0.007+0.002	0.009	0.009+0.002 0.009+0.002	0.011	0.011+0.002 0.011+0.002	0.013
0.094 0.125 0.156	0.007+0.005 0.007+0.005 0.007+0.005	0.012	0.010+0.005 0.010+0.005 0.010+0.005	0.015	0.012+0.005 0.012+0.005 0.012+0.005	0.017	0.014+0.005 0.014+0.005 0.014+0.005	0.019
0.187 0.250	0.010+0.005 0.010+0.005	0.015	0.013+0.005 0.013+0.005	0.018	0.015+0.005 0.015+0.005	0.020	0.017+0.005 0.017+0.005	0.022
0.313 0.375	0.015+0.005 0.015+0.005	0.020	0.018+0.005 0.018+0.005	0.023	0.020+0.005 0.020+0.005	0.025	0.022+0.005 0.022+0.005	0.027

Wills Rings® clearance and tolerance correction values (CTCV) for different plating levels for each free height size in inches.

Internal pressure $\varnothing d7 = \varnothing da + \text{CTCV}$

External pressure $\varnothing d8 = \varnothing di - \text{CTCV}$

Note:

Use $\varnothing da$ for Wills Rings® O for external pressure

Use $\varnothing di$ for Wills Rings® C for external pressure

For example

MOT O L1200-1HS

This is a 0.187" gas filled Wills Rings® O thin wall seal for a 12.00" seal diameter da. It has silver plate at 3 layers, 0.003/0.0035" thickness.

The groove diameter is found from $\varnothing d7 = \varnothing da + \text{CTCV}$

$$\begin{aligned} \text{Hence } \varnothing d7 &= \varnothing da + \text{CTCV} \\ &= 12.00 + 0.022 \\ \varnothing d7 &= 12.022" \end{aligned}$$

See page 18 for Clearance Tolerance Correction Values in Metric.



Part Number Systems for Wills Rings® in Inches

Table XXV Part Number System for Wills Rings® O in Inches

Seal Type	Series	Free Height/ Wall Size inch	Seal Diameter	Quality Characteristic Code	Characteristic Number	Seal Material	Coating Material
M O M: Metal O: O-Ring profile	S Solid T Gas-filled U Non- pressurized	Standard wall	For small dia. up to 9.999" use S - - - this is the seal outside dia. Øda to 3 decimal places	"- Standard Quality "K" X-Ray required "A" Aerospace use	1 = Standard	B Mild steel H Stainless st. AISI 316L (1.4435) E Stainless st. AISI 321 (1.4541) M Inconel® 600 O Copper	W PTFE Q Nickel O Copper I Gold N Indium R Silver 1 layer U Silver 2 layers S Silver 3 layers
		A .063 .014					
		B .094 .018					
		C .125 .020					
		D .156 .025					
		E .187 .032					
		F .250 .040					
		G .313 .050					
		H .375 .060					
	V Pressure vented ID W Pressure vented OD	Thin wall	For larger dia. above 10.000" use L - - - this is the seal outside dia. Øda to 2 decimal places				
		J .035 .006					
		K .063 .010					
		L .094 .010					
		M .125 .010					
		N .156 .010					
		O .187 .010					
		P .250 .020					
		R .375 .020					

Note: MOV/MOW (Vented type Wills Rings® O) seal not available in 0.89 mm (0.035") Free Height size J. Use MOT type or increase to a 1.59 mm (0.063") size instead.

Example 1

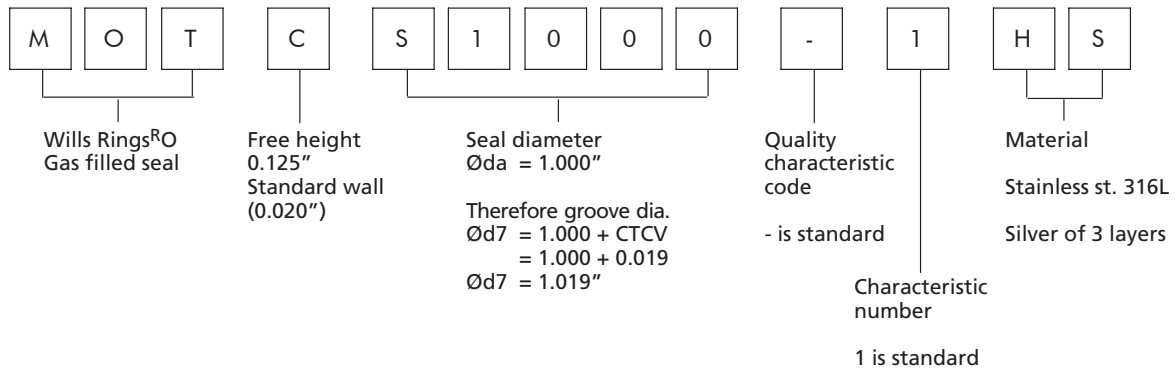

Example 2

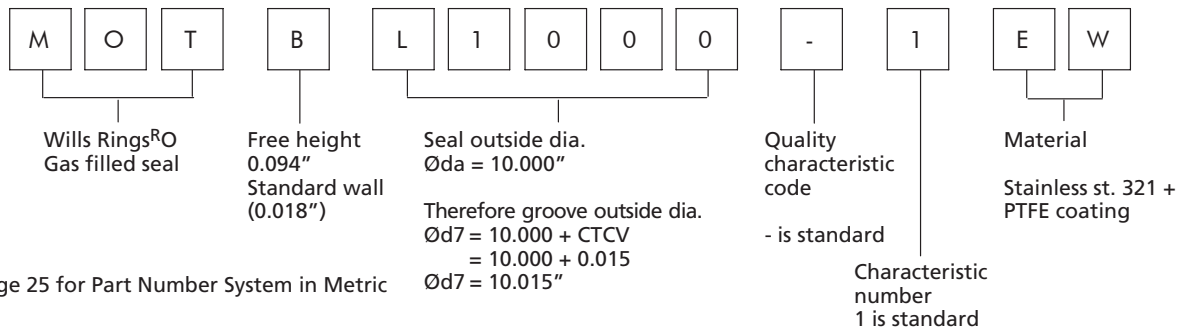

See page 25 for Part Number System in Metric



Table XXVI Part Number System for Wills Rings® C in Inches

Seal Type	Series	Free Height/ Wall Size inch	Seal Diameter	Quality Characteristic Code	Characteristic Number	Seal Material	Coating Material	Treatment
M C M: Metal C: C-Ring profile	X Internal pressure Y External pressure	Standard wall	For small dia. up to 9.999" use	"-" Standard Quality "A" Aerospace use	1=Standard	L Inconel® 718 N Inconel® X750	W PTFE O Copper I Gold N Indium R Silver 1 layer U Silver 2 layers S Silver 3 layers	1 = Work harden 2 = Standard age harden (short cycle) 3 = Age harden (long cycle) 4 = Solution anneal and age harden 5 = Heat treat to NACE MR0175
		A .063 .010	S - - - - this is the seal outside dia. Øda to 3 decimal places					
		B .094 .015						
		C .125 .020						
		D .156 .024						
		E .187 .030	For larger dia. above 10.000" use					
			L - - - - this is the seal outside dia. Øda to 2 decimal places					
		Thin wall						
		K .063 .006						
		L .094 .010	Use outside dia. for internal pressure/outside sealing					
		M .125 .015						
		N .156 .016						
		O .187 .020	Use inside dia. for external pressure/inside sealing					
		P .250 .025						

Example 1

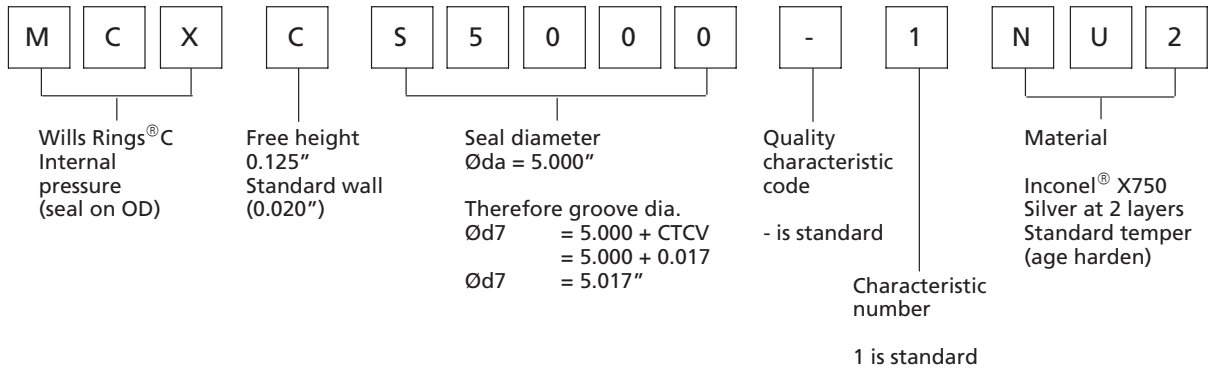

Example 2

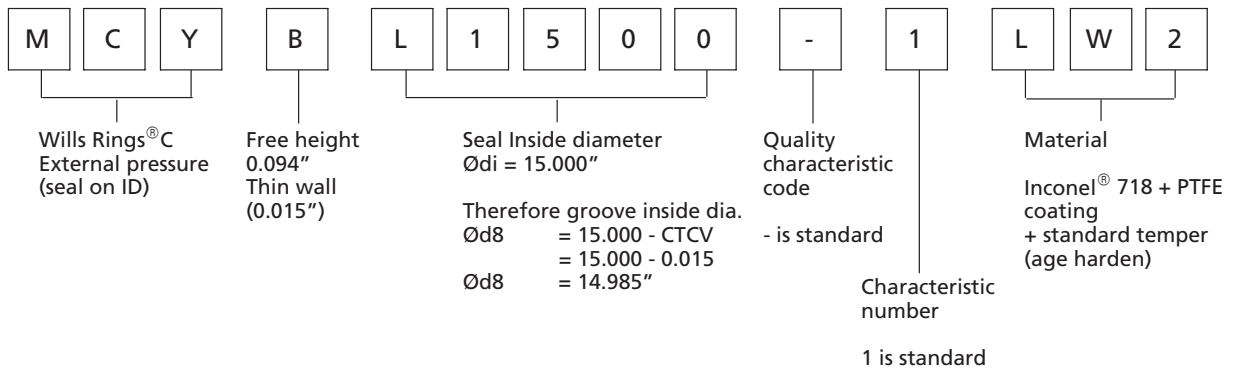

See page 27 for Part Number System in Metric



■ Quality Criteria

The cost-effective use of seals and bearings is highly influenced by the quality criteria applied in production. Seals and bearings manufactured by Trelleborg Sealing Solutions are continuously monitored according to strict quality standards from material acquisition through to delivery.

Certification of our production plants in accordance with international standards EN ISO 9000 meets the specific requirements for quality control and management of purchasing, production and marketing functions.

Our quality policy is consistently controlled by strict procedures and guidelines which are implemented within all strategic areas of the company.

All testing of materials and products is performed in accordance with accepted test standards and specifications, e.g. random sample testing in accordance with DIN ISO 2859 part 1/ANSI/ASQC Z 1.4-1993/ MIL-STD- 105 E. Inspection specifications correspond to standards applicable to individual product groups (e.g. for O-Rings: ISO 3601/DIN 3771).

The tenth digit of our part number defines the quality characteristics of the part. A hyphen indicates compliance with standard quality criteria outlined in this catalogue. Customer-specific requirements are indicated by a different symbol in this position. Customers who require special quality criteria should contact their local Trelleborg Sealing Solutions sales office for assistance. We have experience in meeting all Customer quality requirements.

■ Storage

Seals and bearings are often stored as spare parts for prolonged periods. With a few simple precautions, the shelf life of these products can be considerably lengthened.

Seals and bearings should be stored where they are safe from damage by external influences. Deformation, in particular, should be avoided during storage.

Under the influence of various external factors e.g. heat, moisture, light, oxygen, ozone and as a result of contact with liquid media, the properties of certain materials may change. For example, deformation, ageing and weathering can cause deterioration of the original mechanical and physical properties, depending on the material and shape of the parts.

The following guidelines should be observed to maintain the optimum physical and chemical properties of the parts:

Heat

The ideal temperature for storage is between +5°C/41°F and +25°C/77°F. Direct contact with heaters should be avoided.

Moisture

Parts may be stored dry under normal atmospheric conditions (65% rel. moisture ±10).

Weathering

To protect them against damage, seals and bearings should be kept in the original sealed packaging.

Conversion Tables



SI - Basic Units

Measures	Units	Symbol
Length	Metre	m
Mass	Kilogram	kg
Time	Second	s
Electric current	Ampere	A
Temperature	Kelvin	K
Luminous intensity	Candela	cd
Amount of substance	Mol	mol

Length

	inch	foot	yard	mm	metre
1 inch =		0.0833	0.0278	25.4	0.0254
1 foot =	12		0.333	304.8	0.3048
1 yard =	36	3		914.4	0.9144
1 mm =	0.03937	0.0033	0.00109		0.001
1 metre =	39.37	3.2808	1.0936	1.000	

Torque

	inch-ounce	inch-pound	foot-pound	kg-metre	Newton-metre
1 inch-ounce =		0.0625	0.0052	7.2×10^{-4}	7.06×10^{-3}
1 inch-pound =	16		0.0833	1.152×10^{-2}	0.1130
1 foot-pound =	192	12		0.1383	1.356
1 kg-metre =	1 388.7	86.796	7.233		9.80665
1 Newton-metre =	141.6	8.850	0.7375	0.1020	

Area

	inch ²	foot ²	yard ²	mm ²	m ²
1 inch ² =		0.0069	0.00077	645.16	6.45×10^{-4}
1 foot ² =	144		0.111	92.903	0.0929
1 yard ² =	1.296	9		836.100	0.8361
1 mm ² =	0.0016	1.0764×10^{-5}	1.196×10^{-6}		10^{-6}
1 m ² =	1.550	10.764	1.196	10^6	

Volume

	inch ³	US quart	imp. gallon	foot ³	US gallon	liter
1 inch ³ =		0.0173	0.0036	0.00058	0.0043	0.0164
1 US quart =	57.75		0.2082	0.0334	0.25	0.9464
1 imp. gallon =	277	4.8		0.1604	1.2	4.546
1 foot ³ =	1.728	29.922	6.23		7.48	28.317
1 US gallon =	231	4	0.8327	0.1337		3.785
1 liter =	61.024	1.0567	0.220	0.0353	0.264	

Pressure

	inch Hg	psi	atmosphere	torr	mm Hg	bar	MPa	kg/cm ²
1 inch Hg =		0.491	0.0334	25.4	25.4	0.0339	0.00339	0.0345
1 psi =	2.036		0.0680	51.715	51.715	0.0689	0.00689	0.0703
1 atmosphere =	29.921	14.696		760	760	1.0133	0.10133	1.0332
1 torr =	0.0394	0.0193	0.0013		1	0.0013	0.00013	0.00136
1 mm Hg =	0.0394	0.0193	0.0013	1		0.0013	0.00013	0.00136
1 bar =	29.53	14.504	0.987	749.87	749.87		0.1	1.020
1 MPa =	295.3	145.04	9.869	7498.7	7498.7	10		10.2
1 kg/cm ² =	28.950	14.22	0.968	735.35	735.35	0.980	0.098	

Surface Finish R_a

µm	µin
0.1	4
0.2	8
0.4	16
0.8	32
1.6	64

Temperature

	Kelvin	°C	°F
1 Kelvin =		K - 273.15	K 9/5 - 459.67
1 °C =	°C + 273.15		°C 9/5 + 32
1 °F =	$5/9 (°F-32) + 273.15$	$(°F-32) \times 5/9$	

Density

	ounce/inch ³	pound/foot ³	g/cm ³
1 ounce/inch ³ =		108	1.73
1 pound/foot ³ =	0.0092		0.016
1 g/cm ³ =	0.578	62.43	

Force

	Newton (N)	kilopond (kp)	pound force
1 Newton (N) =		0.10197	0.22481
1 kilopond (kp) =	9.80665		2.20463
1 pound force =	4.4482	0.45359	

Velocity (Speed)

	foot/s	foot/min	mile/hour	metre/s	km/hour
1 foot/s =		60	0.6818	0.3048	1.097
1 foot/min =	0.017		0.0114	0.00508	0.01829
1 mile/hour =	1.4667	88		0.447	1.609
1 metre/s =	3.280	196.848	2.237		3.6
1 km/hour =	0.9113	54.68	0.6214	0.278	

Mass

	ounce	pound	kg
1 ounce =		0.0625	0.0283
1 pound =	16		0.4536
1 kg =	35.274	2.2046	

Contact your local marketing company for further information:

Europe	Telephone	Americas	Telephone
AUSTRIA - Vienna <small>(ALBANIA, BOSNIA AND HERZEGOVINA, MACEDONIA, SERBIA AND MONTENEGRO, SLOVENIA)</small>	+43 (0) 1 406 47 33	AMERICAS - REGIONAL	+1 260 749 9631
BELGIUM - Dion-Valmont <small>(LUXEMBOURG)</small>	+32 (0) 10 22 57 50	BRAZIL - São Paulo	+55 11 3372 4500
BULGARIA - Sofia <small>(ROMANIA)</small>	+359 (0)2 969 95 99	CANADA - Etobicoke, ON	+1 416 213 9444
CROATIA - Zagreb	+385 (0) 1 24 56 387	MEXICO - Mexico City	+52 55 57 19 50 05
CZECH REPUBLIC - Rakovník <small>(SLOVAKIA)</small>	+420 313 529 111	USA, East - Conshohocken, PA	+1 610 828 3209
DENMARK - Hillerød	+45 48 22 80 80	USA, Great Lakes - Fort Wayne, IN	+1 260 482 4050
FINLAND - Vantaa <small>(ESTONIA, LATVIA)</small>	+358 (0) 207 12 13 50	USA, Midwest - Lombard, IL	+1 630 268 9915
FRANCE - Maisons-Laffitte	+33 (0) 1 30 86 56 00	USA, Mountain - Broomfield, CO	+1 303 469 1357
GERMANY - Stuttgart	+49 (0) 711 7864 0	USA, Northern California - Fresno, CA	+1 559 449 6070
GREECE	+41 (0) 21 631 41 11	USA, Northwest - Portland, OR	+1 503 595 6565
HUNGARY - Budaörs	+36 (06) 23 50 21 21	USA, South - N. Charleston, SC	+1 843 747 7656
ITALY - Livorno	+39 0586 22 6111	USA, Southwest - Houston, TX	+1 713 461 3495
THE NETHERLANDS - Barendrecht	+31 (0) 10 29 22 111	USA, West - Torrance, CA	+1 310 371 1025
NORWAY - Oslo	+47 22 64 60 80		
POLAND - Warsaw <small>(LITHUANIA, UKRAINE, BELARUS)</small>	+48 (0) 22 863 30 11	Asia Pacific	Telephone
RUSSIA - Moscow	+7 495 982 39 21	ASIA PACIFIC REGIONAL	+65 6 577 1778
SPAIN - Madrid <small>(PORTUGAL)</small>	+34 (0) 91 71057 30	CHINA - Hong Kong	+852 2366 9165
SWEDEN - Jönköping	+46 (0) 36 34 15 00	CHINA - Shanghai	+86 (0) 21 6145 1830
SWITZERLAND - Crissier	+41 (0) 21 631 41 11	INDIA - Bangalore	+91 (0) 80 2245 5157
TURKEY	+41 (0) 21 631 41 11	JAPAN - Tokyo	+81 (0) 3 5633 8008
UNITED KINGDOM - Solihull <small>(EIRE)</small>	+44 (0) 121 744 1221	KOREA - Anyang	+82 (0) 31 386 3283
AFRICA REGIONAL	+41 (0) 21 631 41 11	MALAYSIA - Kuala Lumpur	+60 (0) 3 9059 6388
MIDDLE EAST REGIONAL	+41 (0) 21 631 41 11	TAIWAN - Taichung	+886 4 2382 8886
		THAILAND - Bangkok	+66 (0) 2732-2861
		SINGAPORE	
		and all other countries in Asia	+65 6 577 1778

www.tss.trelleborg.com

