

# Turcon® Variseal®

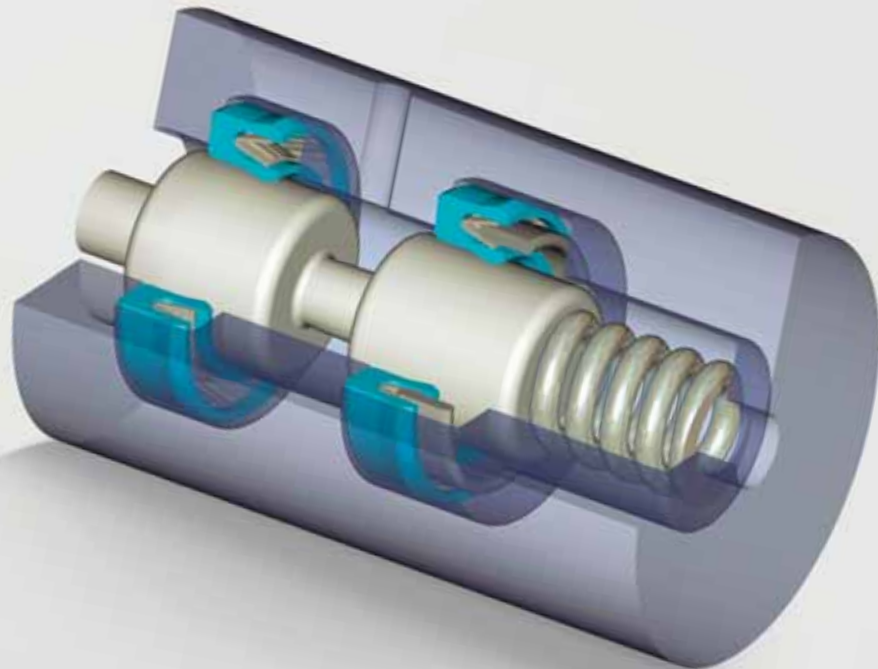

English



**Your Partner for Sealing Technology**



## Your Partner for Sealing Technology

Trelleborg Sealing Solutions is a major international sealing force, uniquely placed to offer dedicated design and development from our market leading product and material portfolio; a one-stop shop providing the best in elastomer, thermoplastic, PTFE and composite technologies for applications in aerospace, industrial, and automotive industries.

With 50-years experience, Trelleborg Sealing Solutions engineers support customers with design, prototyping, production, test and installation using state-of-the-art design tools. An international network of over 70 facilities worldwide includes 30 manufacturing sites, strategically positioned research and development centers, including materials and development laboratories and locations specializing in design and applications.

Developing and formulating materials in-house, we utilize the resource of our material database, including over 2,000 proprietary compounds and a range of unique products.

Trelleborg Sealing Solutions fulfills challenging service requirements, supplying standard parts in volume or a single custom-manufactured component, through our integrated logistical support, which effectively delivers over 40,000 sealing products to customers worldwide.

Facilities are certified to ISO 9001:2000 and ISO/TS 16949:2002. Trelleborg Sealing Solutions is backed by the experiences and resources of one of the world's foremost experts in polymer technology, Trelleborg Group.

ISO 9001:2000

ISO/TS 16949:2002

The information in this brochure is intended to be for general reference purposes only and is not intended to be a specific recommendation for any individual application. The application limits for pressure, temperature, speed and media given are maximum values determined in laboratory conditions. In application, due to the interaction of operating parameters, maximum values may not be achieved. It is vital therefore, that customers satisfy themselves as to the suitability of product and material for each of their individual applications. Any reliance on information is therefore at the user's own risk. In no event will Trelleborg Sealing Solutions be liable for any loss, damage, claim or expense directly or indirectly arising or resulting from the use of any information provided in this brochure. While every effort is made to ensure the accuracy of information contained herewith, Trelleborg Sealing Solutions cannot warrant the accuracy or completeness of information.

To obtain the best recommendation for a specific application, please contact your local Trelleborg Sealing Solutions marketing company.

This edition supersedes all previous brochures.  
This brochure or any part of it may not be reproduced without permission.

© All trademarks are the property of Trelleborg Group.  
The turquoise color is a registered trademark of Trelleborg Group.  
© 2008, Trelleborg Group. All rights reserved.

## Contents

Choosing the right seal for your application .....	2
General .....	3
Turcon® Seal Materials .....	6
Zurcon® Seal Materials .....	7
Spring Types and Materials .....	8
Quality Criteria .....	9
General Design Instructions .....	10
Installation in Closed Grooves .....	11
Half-Open Groove Design for Snap Fitting .....	12
Surface Roughness .....	13
Turcon® Variseal® M2 .....	15
Turcon® Variseal® M2S .....	16
Turcon® Variseal® W .....	17
Turcon® Variseal® H .....	18
Installation Recommendations for Rod Seals - Types M2, MS2, W and H .....	19
Installation Recommendations for Piston Seals - Types M2, M2S, W and H .....	21
Turcon® Variseal® HF .....	23
Installation Recommendations for Turcon® Variseal® HF Flange Seals for Internal Pressure .....	24
Installation Recommendations for Turcon® Variseal® HF Flange Seals for External Pressure / Vacuum .....	26
Turcon® Roto Variseal® .....	28
Installation Recommendation for Turcon® Roto Variseal® .....	30
Special Types .....	32
Storage Instructions .....	34
Conversion Tables .....	35

## ■ Choosing the right seal for your application

Turcon® Variseal® offers major benefits in the design of components such as hydraulic and pneumatic cylinders, in all industries. These include:

- Excellent leak tightness
- High resistance to wear
- No extrusion into gaps
- Withstanding aggressive and abrasive process media
- Very good temperature capabilities
- Low friction
- Compact form
- Simple installation

Turcon® Variseal® is available in a range of geometries and designs that allow the optimum profile to be selected for each application. They can be produced from a wide range of Turcon® materials, our proprietary PTFE based compounds. These are specially formulated for sealing elements and offer superior characteristics specifically matched to the demands of our customers.

When required, Variseal® can also be manufactured in Zurcon®, our proprietary polyethylene based material.

To choose the best Turcon® Variseal® for your application, you must first decide the functional parameters. Table I and II on page 4 and Table III on page 5 can then be used to make an initial selection of seals and materials. These tables give details of where further details can be found in the catalog.

It is also important to consider the quality of the mating surface, which has a significant effect on the function and service life of the sealing system. Guidelines on these are given on pages 13 and 14.

If help is required in specification of a seal then contact Trelleborg Sealing Solutions, to find your local marketing company go to [www.tss.trelleborg.com](http://www.tss.trelleborg.com).

## ■ General

Turcon® Variseal® are single acting, spring-energized seals which are used for dynamic and static applications.

Variseal® are effective in a wide range of applications. They are chosen when higher resistance to chemical media is required, if the seal is required to operate in extremes of temperature and where good extrusion and compression characteristics are needed.

Turcon® Variseal® have three main design characteristics:

1. Application specific U-shaped seal profile
2. Spring geometry suited to the particular application
3. Proven high-performance Turcon® or Zurcon® polymers

Standard products are available from 2 mm up to 2500 mm (8' 2") in diameter along with custom manufactured intermediate sizes, inch (imperial) sizes or special geometries.

### Method of Operation

All Variseal® included in this catalogue have the same operating principle and differ only in their profile form and type of metallic spring used.

The Variseal® spring supplies the load required for sealing at low pressures (Figure 1). The "U" shaped jacket allows fluid pressure to energize the sealing lips, so total sealing pressure rises with increasing operating pressure (Figure 2).

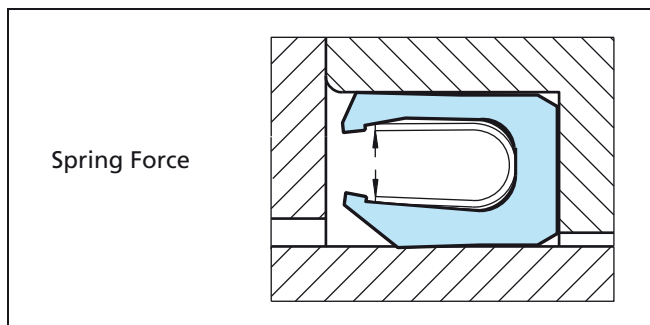

Figure 1 Turcon® Variseal® without system pressure

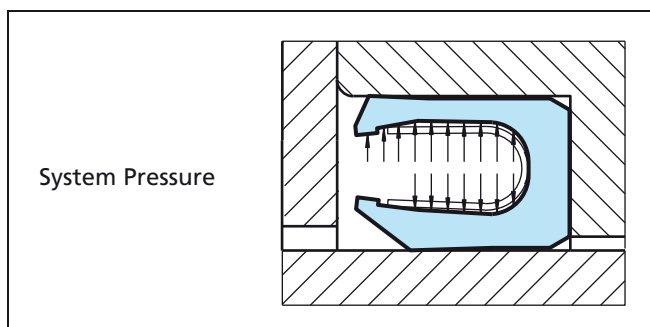

Figure 2 Turcon® Variseal® with system pressure







### Performance

The different types of Variseal® combined with the properties of Turcon® and Zurcon® materials offer design engineers a wide range of solutions to a large number of applications.

The most important characteristics of Variseal® are listed below:

- Very low coefficient of friction
- Good dynamic and static sealing
- Capable of sealing at high speeds up to 15 m/s (49 ft/sec)
- Almost universal chemical compatibility
- Operating temperature of -253 °C up to +300 °C (423 °F to 572 °F)
- Very good thermal resistance
- Permanent elasticity unaffected by contact with chemicals
- Good ageing characteristics
- Low compression set
- Capable of withstanding high pressures above 200 MPa (2000 bar, 29000 psi) when using Back-up Rings
- Very good dry-running properties
- Can be installed in grooves according to MIL-G-5514F and DIN 3771

**Table I Turcon® Variseal® Selection Table**

Seal		Application			Technical Data					Materials	
Type	Page	Type of Application			Maximum Pressure		Working Temp. °C (°F)	Maximum Speed		Standard Materials	
		Static	Reciprocating	Rotary	Dynamic MPa (bar, psi)	Static MPa (bar, psi)		Reciprocating m/s (ft/sec)	Rotating m/s (ft/sec)	Jacket	Spring
<b>M2</b> 	15	C	A	B	45 (450, 6527)	60 (600, 8702)	-70 (-94) to +260 (+500)	15	1	T40	S
<b>M2S</b> 	16	C	A	C	45 (450, 6527)	60 (600, 8702)	-70 (-94) to +260 (+500)	10	0.5	T40	S
<b>W</b> 	17	C	A	B	20 (200, 2900)	60 (600, 8702)	-70 (-94) to +230 (+446)	15	1	T40	S
<b>H</b> 	18	A	B	C	40 (400, 5801)	80 (800, 11603)	-120 (-184) to +260 (+500)	5	0.1	T05	S
<b>HF</b> 	28	A	-	C	40 (400, 5801)	80 (800, 11603)	-200 (-328) to +260 (+500)	-	0.1	T05	S
<b>Roto</b> 	28	B	B	A	15 (150, 2175)	25 (250, 3625)	-100 (-148) to +260 (+500)	10	2	T40	S

Properties: A Excellent B Good C Satisfactory

**Table II Jacket Material Selection Guide**

Contact medium or operating condition	Static or slightly Dynamic	Reciprocating	Rotating
Air, Gas	<b>Turcon® T05</b>	<b>Turcon® T24</b>	<b>Turcon® T24</b>
Water, Steam		<b>Turcon® T40</b>	<b>Turcon® T40</b>
Oil, Crude oil			
General chemical			
Petrochemicals		<b>Turcon® T01</b>	<b>Zurcon® Z80<sup>1)</sup></b>
Food, Drugs	<b>Turcon® T01</b>		<b>Turcon® T01</b>
Vacuum			

<sup>1)</sup> Maximum operating temperature 80°C (172°F). In a pressure-free state, sterilization is possible for a short period at higher temperature

**Table III Turcon® and Zurcon® Material Selection Guide**

Material Code	Material Description	Temperature Range °C (°F)	Media Compatibility	Radiation Resistance <sup>1)</sup> Gray(rad)	Maximum Diameter mm (Imperial)
T01	High-grade virgin polytetrafluoroethylene (PTFE) based material. Very good resistance to chemicals. Colour: white	-253 to +260 (-423 to +500)	A	7 x 10 <sup>2</sup> Gy (7 x 10 <sup>4</sup> )	2500 mm (8' 2")
MF1	A specialist grade of virgin polytetrafluoroethylene (PTFE) available with certification of FDA compliance. Very good resistance to chemicals. Colour: white	-200 to +260 (-328 to +500)	A	7 x 10 <sup>2</sup> Gy (7 x 10 <sup>4</sup> )	2500 mm (8' 2")
T05	High-grade virgin polytetrafluoroethylene (PTFE) based material. For light duties. Greater wear resistance than Turcon® T01. Recommended for lubricated dynamic applications. Colour: turquoise	-200 to +260 (-328 to +500)	A	7 x 10 <sup>2</sup> Gy (7 x 10 <sup>4</sup> )	2500 mm (8' 2")
T24	High-grade formulation of virgin polytetrafluoroethylene (PTFE) based material compounded with carbon additive. Recommended for dynamic applications, in particular dry-running (air and gas). Colour: black	-200 to +260 (-328 to +500)	A	7 x 10 <sup>2</sup> Gy (7 x 10 <sup>4</sup> )	2500 mm (8' 2")
T40	High-grade formulation of virgin polytetrafluoroethylene (PTFE) based material compounded with carbon fibre additive. Excellent wear and low friction characteristics. Suited to reciprocating and rotary applications. Suitable for use in media with poor lubricating properties and for dry-running situations. Colour: anthracite	-200 to +260 (-328 to +500)	A	7 x 10 <sup>2</sup> Gy (7 x 10 <sup>4</sup> )	2500 mm (8' 2")
MF4	A specialist grade of Turcon® T40 compound available with certification of FDA compliance. Colour: anthracite	-200 to +260 (-328 to +500)	A	7 x 10 <sup>2</sup> Gy (7 x 10 <sup>4</sup> )	2500 mm (8' 2")
T78	High grade formulation of virgin polytetrafluoroethylene (PTFE) based material compounded with an aromatic polymer. Especially suited for low pressure rotary applications and running against soft surfaces. Suitable for food industry applications. Colour: beige	-200 to +260 (-328 to +500)	A	7 x 10 <sup>2</sup> Gy (7 x 10 <sup>4</sup> )	2500 mm (8' 2")
Z80	Polyethylene with an extremely high molecular weight. Outstanding wear resistance in dry running applications. Colour: white	-200 to +80 (-328 to +176)  For short periods up to +120 (+248)	B	1 x 10 <sup>5</sup> Gy (1 x 10 <sup>7</sup> )	2500 mm (8' 2")

<sup>1)</sup> Special materials are available for higher radiation loads. For further details on these please contact Trelleborg Sealing Solutions.  
Properties: A Excellent B Good C Satisfactory

## ■ Turcon® Seal Materials

Turcon® materials are high performance thermoplastics specifically developed for sealing applications. They are based on premium-grade PTFE Fluoropolymer resins, with the properties of each compound achieved by the addition of fillers and special processing techniques.

Turcon® materials offer the following benefits:

### Low Coefficient of Friction

Friction is dependent on pressure, contact surface area, speed and lubrication. Turcon® materials have very good friction characteristics. For example, a coefficient of friction on steel mating surfaces of 0.04 can be achieved under lubricated and hydrodynamic conditions.

Turcon® materials do not adhere to their mating surfaces and show only a slight difference between static and dynamic friction, thus eliminating the danger of the stick-slip effect in dynamic applications.

### Chemical Compatibility

Turcon® materials are stable in all hydraulic fluids. Seal materials should be chosen to suit the lubricating properties of hydraulic media and the wear properties of seal and mating surfaces.

There is only a slight change in chemical properties of Turcon® materials, compared to chemically inert virgin PTFE, dependent on the type of filler material added.

### Temperature Range

Turcon® materials can be used at temperatures between -253 °C and +300 °C (-423 °F and 572 °F).

The materials show no brittleness and have high impact strength, even at low temperatures. The limits for low temperatures are dependent on seal design and the thermal contraction of the material. Special designs are available for sealing cryogenic fluids at temperatures below -200 °C (-328 °F).

General service temperature is limited to +260 °C (+500 °F). At temperatures above this, the seal materials begin to lose their strength and are subject to plastic deformation.

### Temperature Cycling

Cyclical temperature fluctuations do not change the properties of Turcon® materials.

### High Surface Speeds

The good mechanical properties of Turcon® materials mean they are excellent in dynamic applications, even under extreme loads.

Turcon® seals offer higher operational reliability than elastomer seals in dynamic situations, especially in dry starting or operating conditions, as they do not suffer from adhesion or heat generation. When the application is lubricated, seal life will be extended further.

### Wear Resistance

Wear resistance is dependent upon material fillers which influence the Turcon® material's mechanical and physical properties. Fillers in Turcon® include bronze, graphite, carbon, carbon fiber, glass fiber and molybdenum disulphide. They can give increased resilience, improved wear resistance, reduced thermal expansion and extremely high resistance to abrasive wear.

### Ageing

Turcon® materials remain unchanged over extended periods. They are practically non-aging and do not become brittle or degrade, even when subject to severe weathering from heat, light, water or salt spray.

### Radiation

Turcon® materials exhibit a low resistance to electron and gamma radiation and are not recommended for use in applications where the accumulated radiation doses exceed  $7 \times 10^2$  Gy ( $7 \times 10^4$  rad). For applications, subject to high radiation doses, special Fluoropolymers such as ETFE and PCTFE or Turcon® materials should be selected.

### Other Properties

Some Turcon® materials have outstanding electrical properties, such as a low dielectric constant or a very high electric strength, even at elevated temperatures.

Physiologically safe Turcon® materials are available which meet the requirements of the German Federal Health Authority (BGA) and the FDA Regulation (Food and Drug Administration) No. 21 CFR, Part 177.

The water absorption of Turcon® materials is < 0.01%.

## ■ Zurcon® Seal Materials

### Zurcon® Z80

Zurcon® Z80 is a polyethylene-based polymer material. It is suitable for medium loads and due to its low water absorption and self-lubricating properties, is ideal for applications in water hydraulics and pneumatics. As it is physiologically safe, it is also suitable for use in food and pharmaceutical processing.

The main characteristics of Zurcon® Z80 are:

#### Low Friction

The dry friction coefficient of Zurcon® Z80 is lower than most other materials though higher than many filled PTFE materials. Zurcon® Z80 forms a self-lubricating, non-stick surface.

#### Chemical Compatibility

Zurcon® Z80 is stable in all hydraulic fluids. It has a high resistance to acids, bases and aggressive media. The material has limited resistance to aromatic and halogenated hydrocarbons.

#### Water Service

Zurcon® Z80 is water repellent and does not swell in water. Its self-lubricating properties in water-based media are excellent, giving it significant advantage over many other materials including PTFE-based ones. This combined with its high strength and wear resistance means it has a long service life in aqueous solutions.

#### Temperature Range

Zurcon® Z80 has a maximum continuous operating temperature of +80 °C (176 °F). Above this temperature its wear resistance and strength begins to decrease. In low-pressure applications it can be used at temperatures of +120 °C (248 °F) for short periods and can be sterilized briefly at even higher temperatures. Its lowest operating temperature is -200 °C (-328 °F).

### Wear Resistance

The abrasive wear resistance of Zurcon® Z80 is 5 to 10 times higher than that of PTFE based materials. It is therefore recommended in applications where seals are in contact with abrasive media such as paints, adhesives, salts, sludges, etc.

Zurcon® Z80 is also highly resistant to extrusion at high pressures.

### Radiation Resistance

The radiation resistance of Zurcon® Z80 is significantly higher than that of PTFE based materials, maintaining good mechanical properties at radiation dosages of up to 100 kGy.

### Applications in the food and pharmaceutical industries

Zurcon® Z80 is physiologically safe and can be used for sealing in food and pharmaceutical processing. It has no odor or taste and is suitable for food contact.

The material complies with the recommendations of the BGA and FDA Regulation 21 CFR, Part 177.

## ■ Spring Types and Materials

A metal spring is incorporated into Turcon® Variseal® to provide elasticity to the seal. This makes the seal permanently elastic, despite changes in operating temperature, pressure or chemicals processed. Each of the three spring types used in Variseal® has unique properties that give them their performance characteristics. The two most important properties of the spring, besides the corrosion resistance of the metal, are load value and deflection range. The spring load effects sealing ability, friction and the wear rate of the seal. The deflection range determines the ability of the Variseal® to take up wear and compensate for variations in gland dimensions.

### V Spring

V Spring is the standard spring type for Variseal® **M2**, Variseal® **M2S** and **Roto Variseal®**. It operates as a set of "cantilever beams", extending from an arc at the bottom of the spring. The shape of the spring causes the load to be focused on the front edge of the sealing lip, giving the seal a positive wiping action. The "V" spring has a moderate load and deflection range.

### Helical Spring

The Helical spring, used in Variseal® **H** and Variseal® **HF**, is made from flat strip formed into a helical coil spring. It has a much higher unit load and a shorter deflection range than the other spring types. Therefore, it is best suited to static or slow dynamic applications, where friction and wear are not the key issues. Variseal® **H** and Variseal® **HF** are the best choices for vacuum, gas and low temperature applications.

### Slantcoil® Spring

The Slantcoil® spring used in Variseal® **W** consists of round wire formed into slanted coils and has a relatively constant load over a wide deflection range. This allows accurate control of friction during the working life of the seal. Its unique design makes it almost impossible to damage the spring by excessive deformation of the seal.

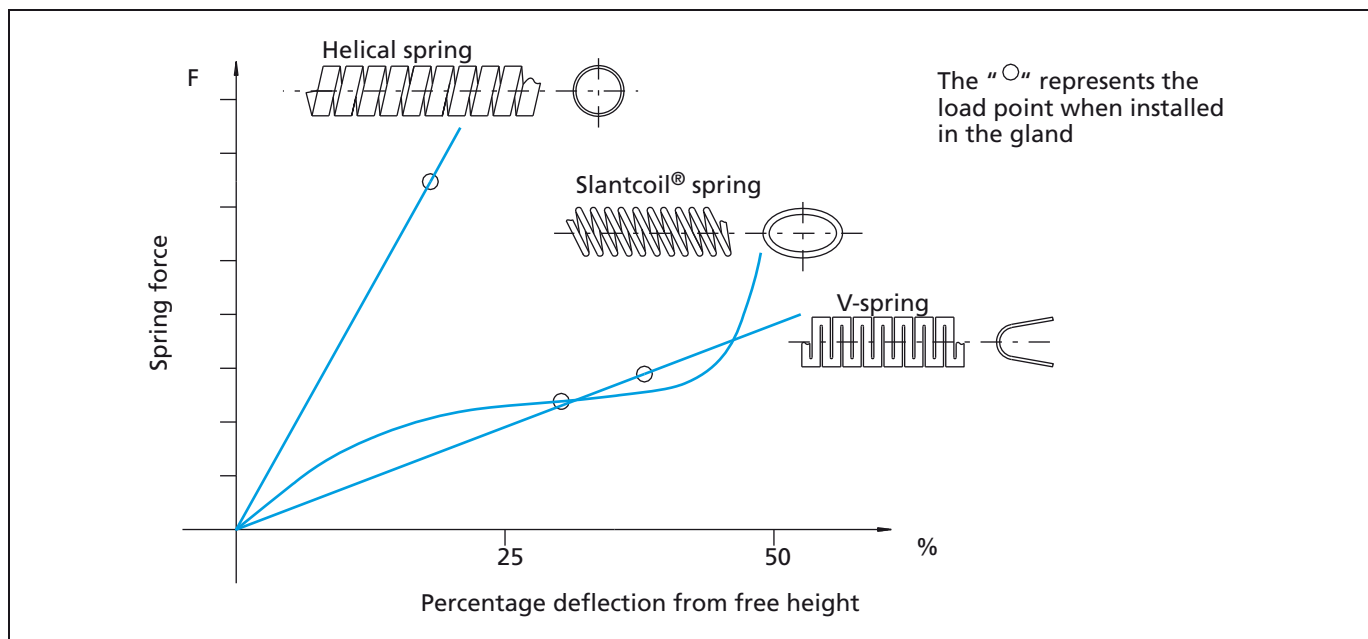

Figure 3 Comparison of load curves for the three spring types

## Spring Materials

The standard spring material for Turcon® Variseal® is stainless steel AISI 301 (spring code S). Two further materials are available for the specific applications, as detailed in the table below.

**Table IV Spring Materials Selection Guide**

Media	Spring materials	Spring order code
<b>For General use e.g.</b> Oil Grease Air Water, steam Solvents Food, drugs Gas	<b>Stainless steel</b> DIN Mat No. 1.4310 (X 12 Cr Ni 177) AISI 301	<b>S</b> (Standard spring material)
<b>For use in corrosive media e.g.</b> Acids Caustics Seawater	<b>Hastelloy® C-276</b> Ni-Mo-16Cr-15W DIN Mat No. 2.4819 UNS N10276	<b>H</b>
<b>For petrochemical use e.g.</b> Crude oil Sour gas	<b>Elgiloy®</b> <sup>1) 2)</sup> DIN Mat No. 2.4711 Co-Cr20-Ni15-Mo UNSR30003	<b>E</b>

® Hastelloy is a registered trademark of Cabot Corporation

® Elgiloy is a registered trademark of the Elgiloy Company

<sup>1)</sup> NACE-approval

<sup>2)</sup> Slantcoil® spring not available

## Quality Criteria

Seals and bearings manufactured by Trelleborg Sealing Solutions are continuously monitored according to strict quality standards from material supply to delivery of finished parts.

Production plants are certified to international standards EN ISO 9001, covering quality control and management of purchasing, production and marketing functions.

All testing of materials and products is performed in accordance with accepted test standards and specifications. Our sealing materials are produced free of chlorofluorinated hydrocarbons and carcinogenic elements.

The tenth digit of our TSS part number defines the quality characteristics of the part. A hyphen indicates compliance with standard quality criteria outlined in this catalogue. Customer-specific requirements are indicated by a different symbol. Customers who require special quality criteria should contact their local Trelleborg Sealing Solutions Company for assistance.

## ■ General Design Instructions

### Lead-in Chamfer for Rod Seals

To avoid damage to the rod seal during installation, lead-in chamfers and rounded edges must be designed into the rod (Figure 4). If this is not possible, an installation tool will be required.

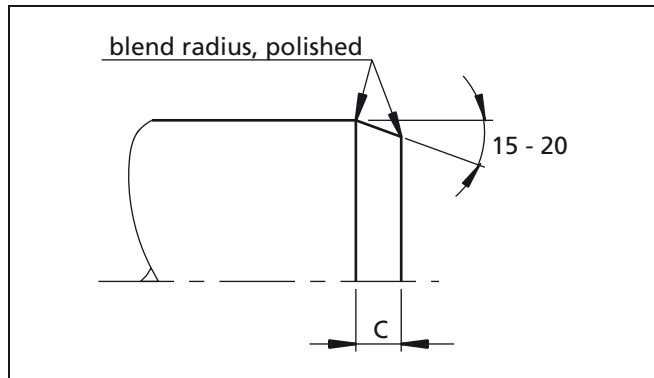

Figure 4 Lead-in chamfer for rod seals

The minimum length of the lead-in chamfer (C) depends on the series of the seal as shown in the following table.

**Table V Lead-in Chamfer on Rods**

Length C minimum mm	TSS Series No.
4.0	RV_0 -
5.0	RV_1 TVM1
5.0	RV_2 TVM2
7.5	RV_3 TVM3
12.0	RV_4 TVM4
12.0	RV_5 -

### Lead-in Chamfer for Piston Seals

To avoid damage to the piston seal during installation, lead-in chamfers and rounded edges must be provided on the bores and cylinders (Figure 5). If this is not possible, an installation tool must be used.

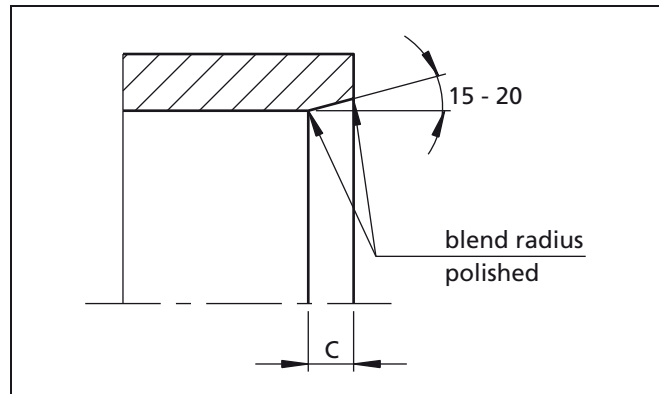

Figure 5 Lead-in chamfer for piston seals

The minimum length of the lead-in chamfer (C) depends on the series of the seal as shown in the following table.

**Table VI Lead-in Chamfer on Pistons**

Length C minimum mm	TSS Series No.
4.0	PV_0
5.0	PV_1
5.0	PV_2
7.5	PV_3
12.0	PV_4
12.0	PV_5

## ■ Installation in Closed Grooves

For simple installation of the Turcon® Variseal®, we recommend that the grooves be split or that a half-open groove be designed into the housing. Installation in closed grooves is possible, depending on the rod and bore diameter, as shown in the following tables VII to X.

**Note:** Roto Variseal® seals can only be installed in split grooves.

### Rod Seals

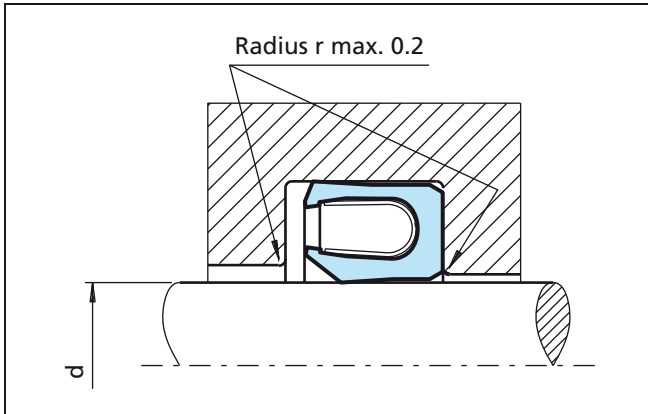

Figure 6 Installation in closed grooves

### Piston Seals

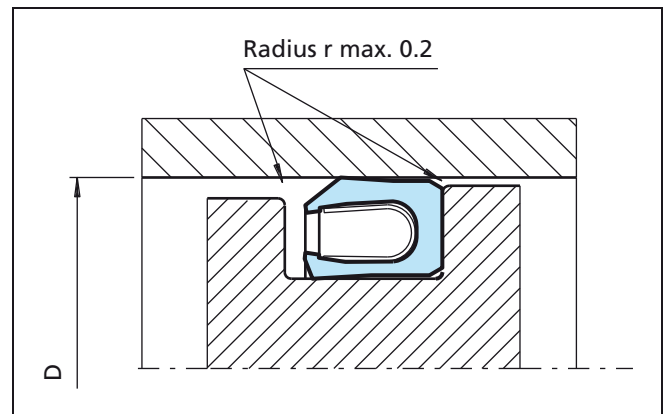

Figure 7 Installation in closed grooves

**Table VII Installation of Turcon® Variseal® M2 and Turcon® Variseal® M2S in closed grooves**

TSS Series No.	dmin. mm
RVA0 and RVC0	30.0
RVA1 and RVC1	70.0
RVA2 and RVC2	110.0
RVA3 and RVC3	300.0
RVA4 and RVC4	500.0

**Table IX Installation of Turcon® Variseal® M2 and Turcon® Variseal® M2S in closed grooves**

TSS Series No.	Dmin. mm
PVA0 and PVC0	35.0
PVA1 and PVC1	50.0
PVA2 and PVC2	70.0
PVA3 and PVC3	105.0
PVA4 and PVC4	140.0

**Table VIII Installation of Turcon® Variseal® H and Turcon® Variseal® W in closed grooves**

TSS Series No.	dmin. mm
RVE0 and RVW0	25.0
RVE1 and RVW1	65.0
RVE2 and RVW2	110.0
RVE3 and RVW3	230.0
RVE4 and RVW4	400.0
RVE5	700.0

**Table X Installation of Turcon® Variseal® H and Turcon® Variseal® W in closed grooves**

TSS Series No.	Dmin. mm
PVE0 and PVW0	20.0
PVE1 and PVW1	30.0
PVE2 and PVW2	45.0
PVE3 and PVW3	60.0
PVE4 and PVW4	95.0
PVE5	300.0

## ■ Half-Open Groove Design for Snap Fitting

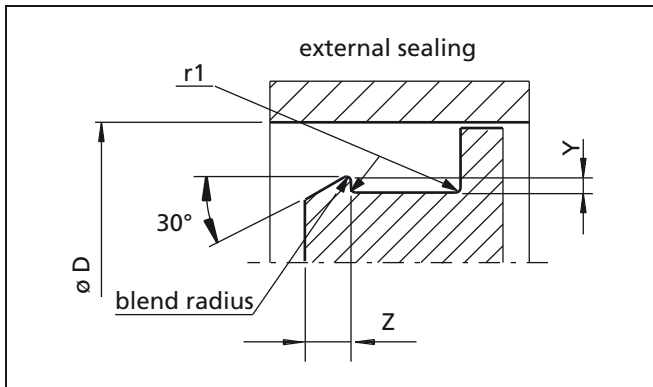

Figure 8 Groove design

**Table XI Dimensions for Groove Design, Snap Fitting - External Sealing**

External sealing TSS Series No.				Step Height <sup>1)</sup>	Chamfer length	Radius
M2	M2S	W	H	Ymin. mm	Zmin. mm	r1max. mm
PVA0	PVC0	PVW0	PVE0	0.4	2.5	0.4
PVA1	PVC1	PVW1	PVE1	0.6	3.5	0.4
PVA2	PVC2	PVW2	PVE2	0.7	3.5	0.6
PVA3	PVC3	PVW3	PVE3	0.8	4.5	0.8
PVA4	PVC4	PVW4	PVE4	0.9	7.5	0.8
-	-	-	PVE5	1.5	7.5	0.8

<sup>1)</sup> Y max = 0.035 x D

Note: It is not always possible to reach recommended "Step height". In case of doubt, contact Trelleborg Sealing Solutions.

### Installation of Turcon® Roto Variseal®

Turcon® Roto Variseal® should only be installed in split grooves.

Carry out installation following the steps below for a concentric and strain-free fit:

- Place seal in the open groove
- Fit the cover and secure loosely
- Install shaft
- Tighten cover onto block

### Shaft Bearing and Radial Clearance

Seals should not be used jointly as a seal and bearing as the sealing function will be reduced. It is recommended that the seals are guided with a roller or a slide bearing. Acceptable eccentricity is detailed in table XIII.

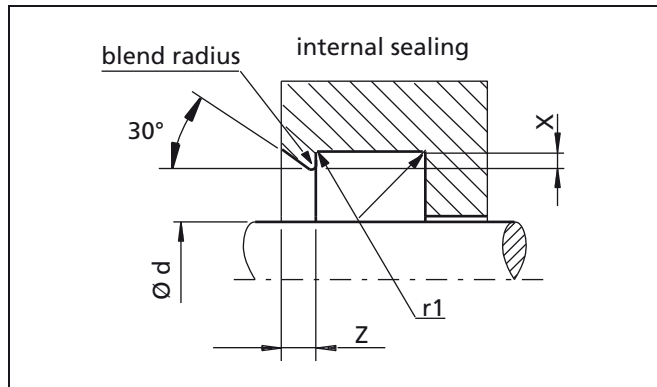

Figure 9 Groove design

**Table XII Dimensions for Groove Design, Snap Fitting - Internal Sealing**

Internal sealing TSS Series No.				Step Height <sup>1)</sup>	Chamfer length	Radius
M2	M2S	W	H	Xmin. mm	Zmin. mm	r1max. mm
RVA0	RVC0	RVW0	RVE0	0.4	2.5	0.4
RVA1	RVC1	RVW1	RVE1	0.6	3.5	0.4
RVA2	RVC2	RVW2	RVE2	0.7	3.5	0.6
RVA3	RVC3	RVW3	RVE3	0.8	4.5	0.8
RVA4	RVC4	RVW4	RVE4	0.9	7.5	0.8
-	-	-	RVE5	1.5	7.5	0.8

<sup>1)</sup> X max = 0.02 x D

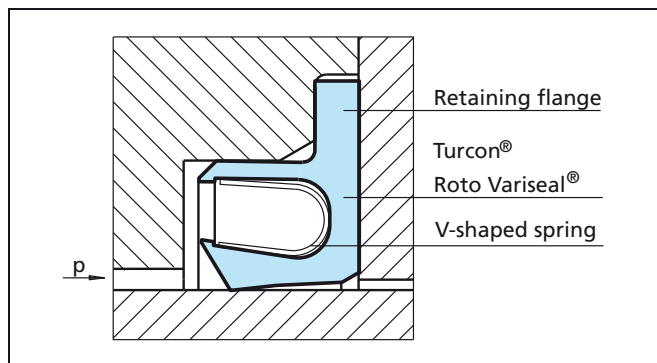

Figure 10 Turcon® Roto Variseal®

**Table XIII Permissible Eccentricity for Turcon® Roto Variseal®**

TSS Series No.	Max. allowable deviation mm
TVM1	0.05
TVM2	0.10
TVM3	0.15
TVM4	0.20

## ■ Surface Roughness

The functional reliability and service life of a sealing system is dependent upon the quality and surface finish of the mating surface to be sealed.

Scores, scratches, pores, concentric or spiral machining marks are not permitted. Higher demands must be made on the surface finish of dynamic mating surfaces than of static mating surfaces. (Table XIV).

The characteristics most frequently used to describe the surface micro finish  $R_a$ ,  $R_z$  and  $R_{max}$  are defined in DIN 4762/ISO 4287/1. These characteristics are not sufficient for assessing the suitability of a surface finish in seal engineering.

The material contact area  $M_r$  (previously percentage contact area  $t_p$ ) in accordance with ISO 4287/1, must also be taken into consideration. The significance of this surface specification is illustrated in Figure 11. It shows that specification of  $R_a$  and  $R_z$  does not describe the profile form accurately enough. The material contact area  $M_r$  is essential to assess surface suitability, as the specific profile form determines this parameter. This in turn is directly dependent on the machining process employed. Figure 12 shows a printout from a commercially available surface measuring instrument. It contains all the information necessary to permit a precise description of a surface finish. Trelleborg Sealing Solutions recommends that the following surface finishes be observed:

**Table XIV Surface Roughness**

Recommended Maximum Surface Roughness $\mu\text{m}$			
Media	Rotary Surface <sup>1)</sup>	Reciprocating Surface	Static Groove Surface
Cryogenic and low molecular gases Hydrogen, Helium, Freon, Oxygen Nitrogen	$R_{max} = 1.0 \mu\text{m}$ $R_z = 0.63 \mu\text{m}$ $R_a = 0.1 \mu\text{m}$	$R_{max} = 2.5 \mu\text{m}$ $R_z = 1.6 \mu\text{m}$ $R_a = 0.2 \mu\text{m}$	$R_{max} = 3.5 \mu\text{m}$ $R_z = 2.2 \mu\text{m}$ $R_a = 0.3 \mu\text{m}$
Low viscosity fluids Water, Alcohols, Hydrazine, Gaseous nitrogen, Natural gas, Skydrol, air	$R_{max} = 2.5 \mu\text{m}$ $R_z = 1.6 \mu\text{m}$ $R_a = 0.2 \mu\text{m}$	$R_{max} = 3.5 \mu\text{m}$ $R_z = 2.2 \mu\text{m}$ $R_a = 0.3 \mu\text{m}$	$R_{max} = 5.0 \mu\text{m}$ $R_z = 3.5 \mu\text{m}$ $R_a = 0.6 \mu\text{m}$
High viscosity fluids Hydraulic oils, Crude oil, Gear oil, Sealants, Glue, Milkproducts	$R_{max} = 2.5 \mu\text{m}$ $R_z = 1.6 \mu\text{m}$ $R_a = 0.2 \mu\text{m}$	$R_{max} = 4.0 \mu\text{m}$ $R_z = 2.5 \mu\text{m}$ $R_a = 0.4 \mu\text{m}$	$R_{max} = 6.5 \mu\text{m}$ $R_z = 5.0 \mu\text{m}$ $R_a = 0.8 \mu\text{m}$

<sup>1)</sup> The sealing surface must be free from spiral grooves.

The material contact area  $M_r$  should be approximately 50% to 70%, determined at a cut depth  $c = 0.25 \times R_z$ , relative to a reference line of  $C_{ref}$ . 5%.

Figure 11 shows two surface profiles, both of which give nearly the same values for  $R_z$  in the test procedure. The difference shows up when the material contact areas are compared. These show that the upper profile with  $M_r=70\%$  has the better seal to mating surface ratio.



Surface profile	$R_a$	$R_z$	$M_r$
closed profile form 	0.1	1.0	70%
open profile form 	0.2	1.0	15%

Figure 11 Profile forms of surfaces

## Test Procedure

Depending on the current test program, the test procedure can contain the following elements:

- Company text (1)
- Workpiece text (2)
- Program number, measurement number, test conditions (3)
- Characteristics (4)
- Material contact area (5)
- Characteristic curves (6)
- Profile curve (7)

1	Trelleborg Sealing Solutions		
	Perthometer S3P V2.1		
2	Obj.:	Piston rod	
	Name:	GJ	
	Date.:	19.05.93 09:40	
3	Programm		6
	Measuring		2
	T1 RFHTB-50	50	1
	LT	5.600 mm	
	LM	4.000 mm	
	VB	25.00 µm	
4	LC	GS 0.800 mm	
	RA	0.079 µm	
	RZ	0.775 µm	
	RMAX	1.215 µm	
	RK	0.221 µm	
	RPK	0.089 µm	
	RVK	0.131 µm	
	LC	GS 0.800 mm	
5	R	MR ( 0.125 5)	0%
	R	MR ( 0.000 5)	5% C ref
	R	MR (- 0.050 5)	13%
	R	MR (- 0.100 5)	30%
	R	MR (- 0.150 5)	52%
	R	MR (- 0.200 5)	73%
	R	MR (- 0.250 5)	87%
	R	MR (- 0.300 5)	95%
	R	MR (- 0.350 5)	98%
	R	MR (- 0.400 5)	99%
	R	MR (- 0.450 5)	99%
	R	MR (- 0.500 5)	100%
	R	MR (- 0.550 5)	100%
	R	MR (- 0.600 5)	100%

## Evaluation of the test procedure

- a) The values for  $R_a$ ,  $R_z$  and  $R_{max}$  correspond to our recommendations.
- b) The cut length is calculated with  $c = 0.25 \cdot R_z = 0.25 \cdot 0.7752 = \text{approx. } 0.200$  with a material contact area  $M_r = \text{approx. } 70\%$
- c) The ratio  $R_z/R_a = 9.81$  indicates a closed profile.

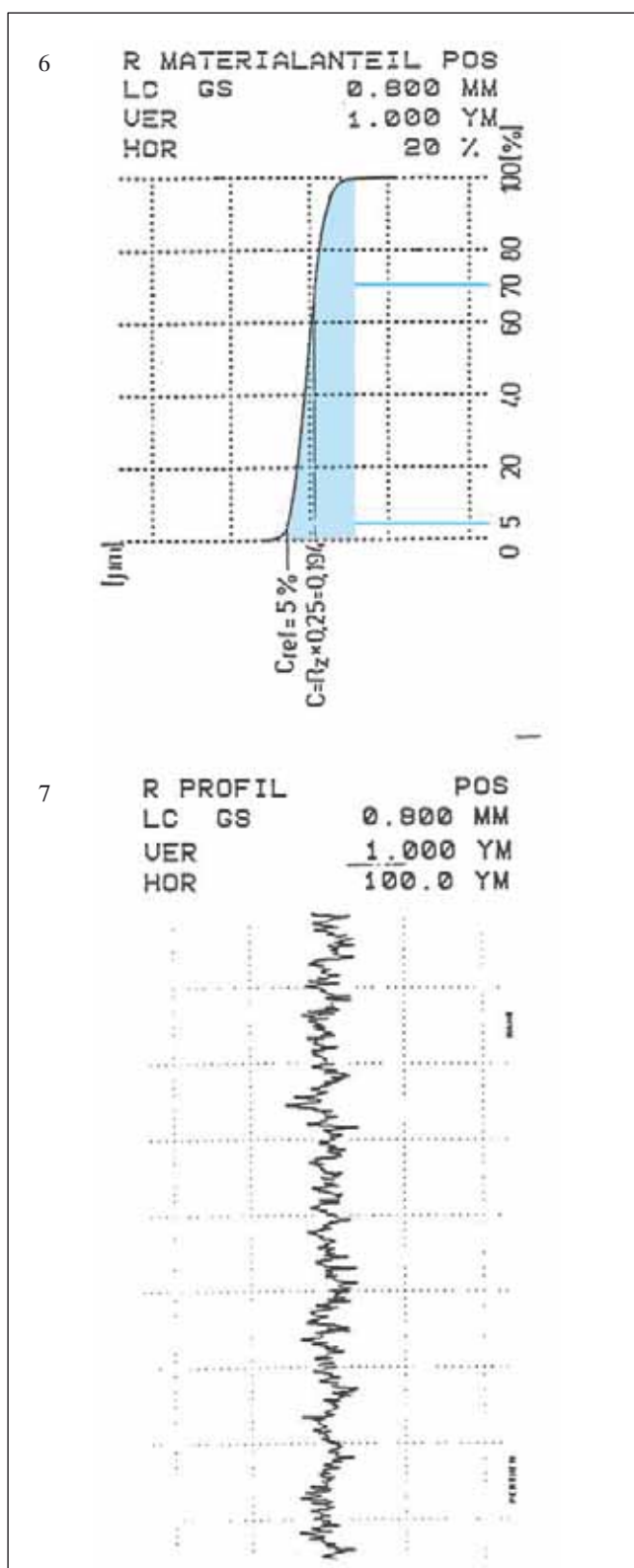

Figure 12 Measurement printout

## ■ Turcon® Variseal® M2

### Description

Turcon® Variseal® M2 is a single acting seal consisting of a U-shaped jacket and a V-shaped corrosion resistant spring.

Variseal® M2 has an asymmetric seal profile. The heavy profile of its dynamic lip with an optimized front angle offers good leakage control, reduced friction and long service life.

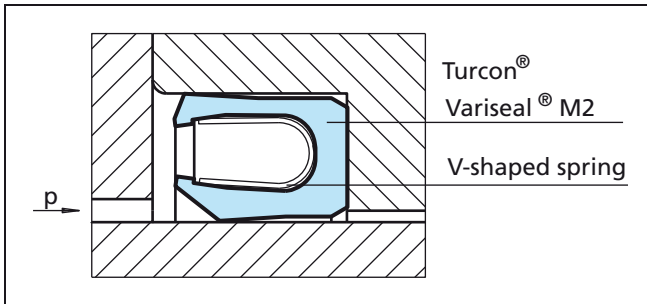

Figure 13 Turcon® Variseal® M2

### Areas of Application

- Hydraulic components, e.g. cylinders, valves, pumps, etc.
- Chemical processing equipment
- Pharmaceutical processing
- Aerospace
- Food and beverage processing
- Spindle seals for machine tools
- Pneumatics, cylinders and valves

### Advantages

- Suitable for reciprocating and rotary applications
- Low coefficient of friction
- Stick-slip free operating
- High abrasion resistance
- Dimensionally stable
- Resistant to most fluids, chemicals and gases
- Withstands rapid changes in temperature
- Safe for contact with food and pharmaceuticals
- Excellent resistance to ageing
- Can be sterilized
- Available in Hi-Clean version
- Interchangeable with O-Ring and Back-up Ring combinations to MIL - G - 5514F and ISO 6194

### Technical Data

Operating pressure:	Maximum dynamic load: 45 MPa (450 bar, 6527 psi) Maximum static load: 60 MPa (600 bar, 8702 psi)
Speed:	Reciprocating up to 15 m/s (49 ft/sec) Rotating up to 1 m/s (3 ft/sec)
Operating temperature:	-70 °C (-94 °F) up to +260 °C (+500 °F) Special Turcon® and Zurcon® materials as well alternative spring materials are available for applications outside this temperature range.
Media compatibility:	Virtually all fluids, chemicals and gases.
Note:	At high temperatures operating pressures and speeds are lower.

### Standard Materials

Jacket:	Material compound <b>T40</b>
Spring material:	Spring code <b>S</b> (stainless steel), Material No. 1.4310 (AISI 301)

### Series Designation

For rod seal:	<b>RVA</b> (internal dynamic surface)
For piston seal:	<b>PVA</b> (external dynamic surface)

Our installation recommendations can be found on pages 19 to 22.

## ■ Turcon® Variseal® M2S

### Description

Turcon® Variseal® M2S is a single acting seal consisting of a U-shaped jacket and a V-shaped corrosion resistant spring.

Variseal® M2S has an asymmetric seal profile. The heavy profile of its dynamic lip is optimized, offering long service life and a good scraping ability even in media with high viscosity.

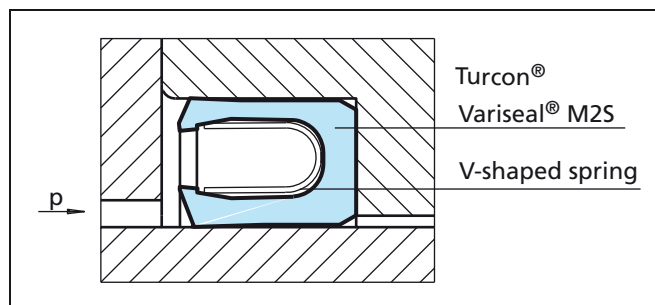

Figure 14 Turcon® Variseal® M2S

### Areas of Application

- Hydraulic components with highly viscous media
- Food processing, for example bottling plants for dairy and food products
- Pharmaceutical and chemical industries
- Processing of sealing compounds, adhesives, pastes, etc.
- Media with particle ingress

### Advantages

- Suitable for reciprocating and rotary movement
- Excellent scraping ability
- High abrasion resistance
- Dimensionally stable
- Resistant to most fluids and chemicals
- Safe for contact with food and pharmaceuticals
- Excellent resistance to ageing
- Can be sterilized
- Available in Hi-Clean version
- Interchangeable with O-Ring and Back-up Ring combinations to MIL - G - 5514F and ISO 6194

### Technical Data

Operating pressure:	Maximum dynamic load: 45 MPa (450 bar, 6527 psi) Maximum static load: 60 MPa (600 bar, 8702 psi)
Speed:	Reciprocating up to 10 m/s (33 ft/sec) Rotating up to 0.5 m/s (1.6 ft/sec)
Operating temperature:	-70 °C (-94 °F) up to +260 °C (+500 °F) Special Turcon® and Zurcon® materials are available for applications outside this temperature range.
Media compatibility:	Fluids of medium to high viscosity or containing hard particles.
Note:	At high temperatures operating pressures and speeds are lower.

### Standard Materials

Jacket:	Material code <b>T40</b>
Spring material:	Spring code <b>S</b> (stainless steel), Material No. 1.4310 (AISI 301)

### Series Designation

For piston seal:	<b>PVC</b> (external dynamic surface)
For rod seal:	<b>RVC</b> (internal dynamic surface)

Our installation recommendations can be found on pages 19 to 22.

## ■ Turcon® Variseal® W

### Description

Turcon® Variseal® W is a single acting seal consisting of a U-shaped jacket and a corrosion resistant Slantcoil® spring.

The Slantcoil® spring in the Variseal® W provides an almost constant load irrespective of hardware, tolerances, eccentricity and seal wear.

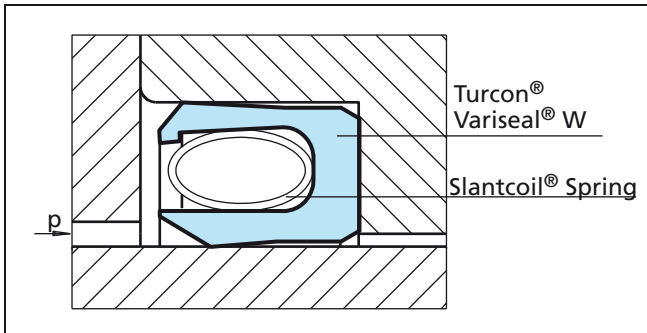

Figure 15 Turcon® Variseal® W

### Areas of Application

- Hydraulic or pneumatic measuring instruments
- Servo valves, pressure switches
- Electronic equipment
- Laboratory apparatus

### Advantages

- Suitable for reciprocating and rotary movement
- Constant initial squeeze of spring over a large control area
- Almost constant friction for low-pressure applications = 2 MPa (20 bar, 290 psi)
- High abrasion resistance
- Dimensionally stable
- Resistant to most fluids, chemicals and gases
- Withstands rapid changes in temperature
- Interchangeable with O-Ring and Back-up Ring combination to MIL - G - 5514F and ISO 6194

### Technical Data

Operating pressure:	Maximum dynamic load: 20 MPa (200 bar, 2900 psi) Maximum static load: 60 MPa (600 bar, 8702 psi)
Speed:	Reciprocating up to 15 m/s (49 ft/sec) Rotating up to 1 m/s (3 ft/sec)
Operating temperature:	-70 °C (-94 °F) up to +230 °C (+446 °F)
Media compatibility:	Virtually all fluids, chemicals and gases.
Note:	At high temperatures operating pressures and speeds are lower.

### Standard Materials

Jacket:	Material code <b>T40</b>
Spring material:	Spring code <b>S</b> (stainless steel), Material No. 1.4310 (AISI 301)

### Series Designation

For piston seal:	<b>PVW</b> (external dynamic surface)
For rod seal:	<b>RVW</b> (internal dynamic surface)

Our installation recommendations can be found on pages 19 to 22.

## ■ Turcon® Variseal® H

### Description

Turcon® Variseal® H is a single acting seal consisting of a U-shaped jacket and a helical wound corrosion resistant spring.

The helical ribbon spring of Variseal® H has a high spring loading, which gives excellent sealing integrity at low pressure and even in vacuum. Variseal® H is suitable for static applications and ideal in low speed applications.

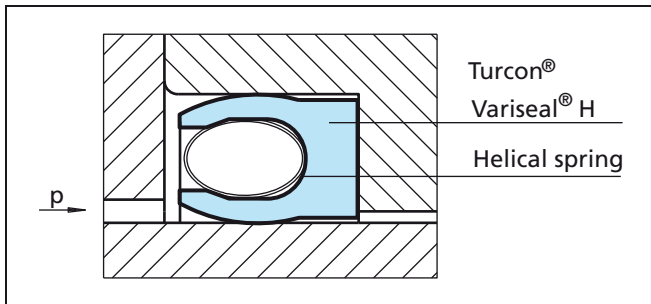

Figure 16 Turcon® Variseal® H

### Areas of Application

- Compressors
- Ball valves
- Construction equipment and plant
- Chemical processing
- Crude oil and natural gas installations
- Cryogenic engineering
- Nuclear power engineering
- Aerospace
- Vacuum applications
- Pivot joints
- Gas chromatographs

### Advantages

- High contact pressure
- Excellent sealing integrity in gas and fluid applications
- Withstands rapid changes in temperature
- Good sealing ability when surfaces are not ideal
- No assembly tools are required for larger diameter seals
- Excellent resistance to ageing
- Interchangeable with O-Ring and Back-up Ring combinations

### Technical Data

Operating pressure:	Maximum dynamic load: 20 MPa (200 bar, 2900 psi) Maximum static load: 80 MPa (600 bar, 11603 psi)
Speed:	Reciprocating up to 5 m/s (16 ft/sec) Rotating up to 0.1 m/s (0.3 ft/sec)
Operating temperature:	-120 °C (-248 °F) up to +260 °C (+500 °F)
Media compatibility:	Virtually all fluids, chemicals and gases.
Note:	Consult Trelleborg Sealing Solutions for applications outside these parameters.

### Standard Materials

Jacket:	Material compound <b>T05</b>
Spring material:	Spring code <b>S</b> (stainless steel), Material No. 1.4310 (AISI 301)

### Series Designation

Rod seal:	<b>RVE</b> (internal dynamic surface)
Piston seal:	<b>PVE</b> (external dynamic surface)

Our Installation recommendations can be found on pages 19 to 22.

Installation Recommendations for Rod Seals - Types M2, MS2, W and H

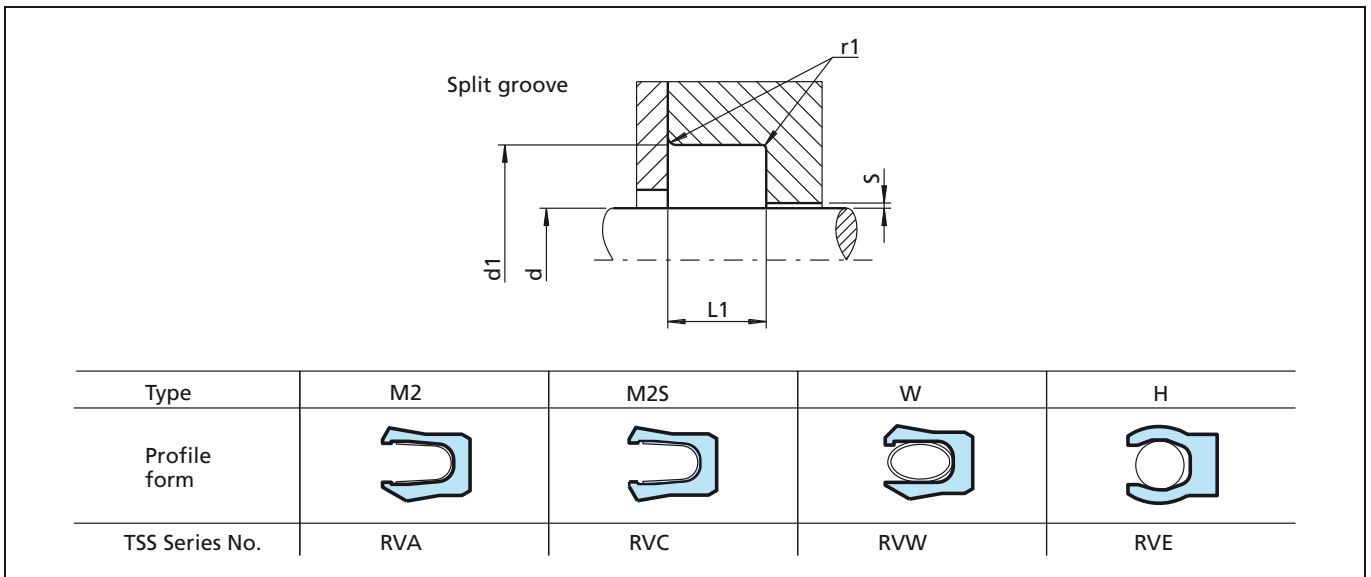

Figure 17 Installation drawing

Table XV Installation Dimensions

TSS Series No. for types				Rod Diameter d h9 mm		Groove Diameter	Groove Width	Radius	Radial Clearance <sup>3)</sup> S max.* mm			
M2	M2S	W	H	Standard Range	Extended Range <sup>1)</sup>	d <sub>1</sub> H9 mm	L <sub>1</sub> +0.2 mm	r1max. mm	<2 MPa (20 bar)	<10 MPa (100 bar)	<20 MPa (200 bar)	<40 MPa (400 bar)
RVA0	RVC0	RVW0	RVE0	3.0 - 9.9	3.0 - 40.0	d + 2.9	2.4	0.4	0.20	0.10	0.08	0.05
RVA1	RVC1	RVW1	RVE1	10.0 - 19.9	6.0 - 200.0 <sup>2)</sup>	d + 4.5	3.6	0.4	0.25	0.15	0.10	0.07
RVA2	RVC2	RVW2	RVE2	20.0 - 39.9	10.0 - 400.0 <sup>2)</sup>	d + 6.2	4.8	0.6	0.35	0.20	0.15	0.08
RVA3	RVC3	RVW3	RVE3	40.0 - 119.9	20.0 - 700.0 <sup>2)</sup>	d + 9.4	7.1	0.8	0.50	0.25	0.20	0.10
RVA4	RVC4	RVW4	RVE4	120.0 - 630.0	35.0 - 1600.0 <sup>2)</sup>	d + 12.2	9.5	0.8	0.60	0.30	0.25	0.12
-	-	-	RVE5	1000.0 - 2500.9	80.0 - 2500.0 <sup>2)</sup>	d + 19.0	15.0	0.8	0.90	0.50	0.40	0.20

\* At pressures > 40 MPa: S max. = H8/f8 reference limit and fits BS EN 20286 - 1 & 2

<sup>1)</sup> Available on request

<sup>2)</sup> For diameters larger than the standard range and for pressures above 40 MPa contact Trelleborg.

<sup>3)</sup> We recommend that the gap dimensions be reduced for temperatures ≥ 80 °C (176 °F)

Ordering Example

Turcon® Variseal® Type M2, TSS Series No. RVA3 from Table XV.

Rod diameter: d = 80.0 mm  
 TSS Part No.: RV - 300800 (from Table XVI).

For selection of another seal type, insert the appropriate TSS Series No. at the beginning of the TSS Article Number.

Other materials:  
 Seal ring materials, see page 5, Table III.  
 Spring materials, see page 9, Table IV.

\*\* For diameters ≥ 1000mm multiply only by factor 1.  
 Example: RVE5 for diameter 1200mm.  
 Order number.:RVE5X1200 - T40S.

TSS Article No	RVA3	0	0800	-	T40	S	(D)
TSS Series No.							
Type (Standard)							
Rod Diameter x 10**							
Quality Index (Standard)							
Material code - Seal ring							
Material code - Spring							
Hi-Clean - (option)							

# Turcon® Variseal® M2, M2S, W and H

**Table XVI Preferred Series / Internal Sealing**

Rod Diameter	Groove Diameter	Groove Width	TSS Part No.
d h9 mm	d <sub>1</sub> H9 mm	L <sub>1</sub> +0.2 mm	
3.0	5.9	2.4	RV_000030
<b>4.0</b>	<b>6.9</b>	<b>2.4</b>	<b>RV_000040</b>
<b>5.0</b>	<b>7.9</b>	<b>2.4</b>	<b>RV_000050</b>
<b>6.0</b>	<b>8.9</b>	<b>2.4</b>	<b>RV_000060</b>
<b>8.0</b>	<b>10.9</b>	<b>2.4</b>	<b>RV_000080</b>
<b>10.0</b>	<b>14.5</b>	<b>3.6</b>	<b>RV_100100</b>
<b>12.0</b>	<b>16.5</b>	<b>3.6</b>	<b>RV_100120</b>
<b>14.0</b>	<b>18.5</b>	<b>3.6</b>	<b>RV_100140</b>
15.0	19.5	3.6	RV_100150
<b>16.0</b>	<b>20.5</b>	<b>3.6</b>	<b>RV_100160</b>
<b>18.0</b>	<b>22.5</b>	<b>3.6</b>	<b>RV_100180</b>
<b>20.0</b>	<b>26.2</b>	<b>4.8</b>	<b>RV_200200</b>
<b>22.0</b>	<b>28.2</b>	<b>4.8</b>	<b>RV_200220</b>
<b>25.0</b>	<b>31.2</b>	<b>4.8</b>	<b>RV_200250</b>
<b>28.0</b>	<b>34.2</b>	<b>4.8</b>	<b>RV_200280</b>
30.0	36.2	4.8	RV_200300
<b>32.0</b>	<b>38.2</b>	<b>4.8</b>	<b>RV_200320</b>
35.0	41.2	4.8	RV_200350
<b>36.0</b>	<b>42.2</b>	<b>4.8</b>	<b>RV_200360</b>
<b>40.0</b>	<b>49.4</b>	<b>7.1</b>	<b>RV_300400</b>
42.0	51.4	7.1	RV_300420
<b>45.0</b>	<b>54.4</b>	<b>7.1</b>	<b>RV_300450</b>
48.0	57.4	7.1	RV_300480
<b>50.0</b>	<b>59.4</b>	<b>7.1</b>	<b>RV_300500</b>
52.0	61.4	7.1	RV_300520
55.0	64.4	7.1	RV_300550
<b>56.0</b>	<b>65.4</b>	<b>7.1</b>	<b>RV_300560</b>
60.0	69.4	7.1	RV_300600
<b>63.0</b>	<b>72.4</b>	<b>7.1</b>	<b>RV_300630</b>
65.0	74.4	7.1	RV_300650
<b>70.0</b>	<b>79.4</b>	<b>7.1</b>	<b>RV_300700</b>
75.0	84.4	7.1	RV_300750
<b>80.0</b>	<b>89.4</b>	<b>7.1</b>	<b>RV_300800</b>
85.0	94.4	7.1	RV_300850
<b>90.0</b>	<b>99.4</b>	<b>7.1</b>	<b>RV_300900</b>
95.0	104.4	7.1	RV_300950
<b>100.0</b>	<b>109.4</b>	<b>7.1</b>	<b>RV_301000</b>
105.0	114.4	7.1	RV_301050
<b>110.0</b>	<b>119.4</b>	<b>7.1</b>	<b>RV_301100</b>
115.0	124.4	7.1	RV_301150
120.0	132.2	9.5	RV_401200
<b>125.0</b>	<b>137.2</b>	<b>9.5</b>	<b>RV_401250</b>
130.0	142.2	9.5	RV_401300
135.0	147.2	9.5	RV_401350
<b>140.0</b>	<b>152.2</b>	<b>9.5</b>	<b>RV_401400</b>
150.0	162.2	9.5	RV_401500
<b>160.0</b>	<b>172.2</b>	<b>9.5</b>	<b>RV_401600</b>
170.0	182.2	9.5	RV_401700
<b>180.0</b>	<b>192.2</b>	<b>9.5</b>	<b>RV_401800</b>
190.0	202.2	9.5	RV_401900
<b>200.0</b>	<b>212.2</b>	<b>9.5</b>	<b>RV_402000</b>

Rod Diameter	Groove Diameter	Groove Width	TSS Part No.
d h9 mm	d <sub>1</sub> H9 mm	L <sub>1</sub> +0.2 mm	
210.0	222.2	9.5	RV_402100
<b>220.0</b>	<b>232.2</b>	<b>9.5</b>	<b>RV_402200</b>
230.0	242.2	9.5	RV_402300
240.0	252.2	9.5	RV_402400
<b>250.0</b>	<b>262.2</b>	<b>9.5</b>	<b>RV_402500</b>
<b>280.0</b>	<b>292.2</b>	<b>9.5</b>	<b>RV_402800</b>
300.0	312.2	9.5	RV_403000
<b>320.0</b>	<b>332.2</b>	<b>9.5</b>	<b>RV_403200</b>
350.0	362.2	9.5	RV_403500
<b>360.0</b>	<b>372.2</b>	<b>9.5</b>	<b>RV_403600</b>
400.0	412.2	9.5	RV_404000

The rod diameters in **bold type** correspond to the recommendations of ISO 3320. Other dimensions and intermediate sizes up to 2500 mm diameter, including imperial (inch) sizes can be supplied.

\*\* For diameters  $\geq 1000$  mm multiply only by factor 1.

Example: RVE5X for diameter 1200 mm. TSS Article No.: RVE5X1200 - T40S.

## Determination of the TSS Article number

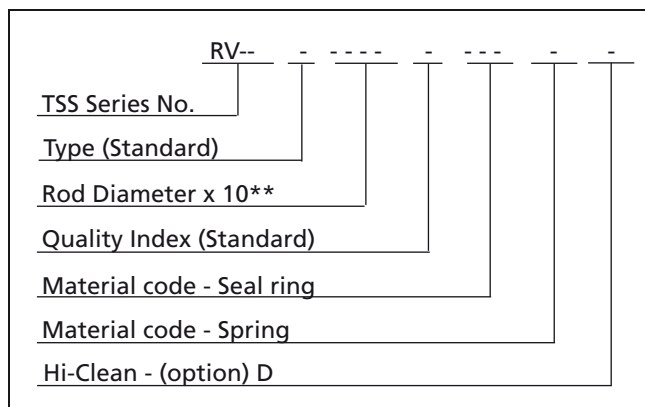

## Installation Recommendations for Piston Seals - Types M2, M2S, W and H

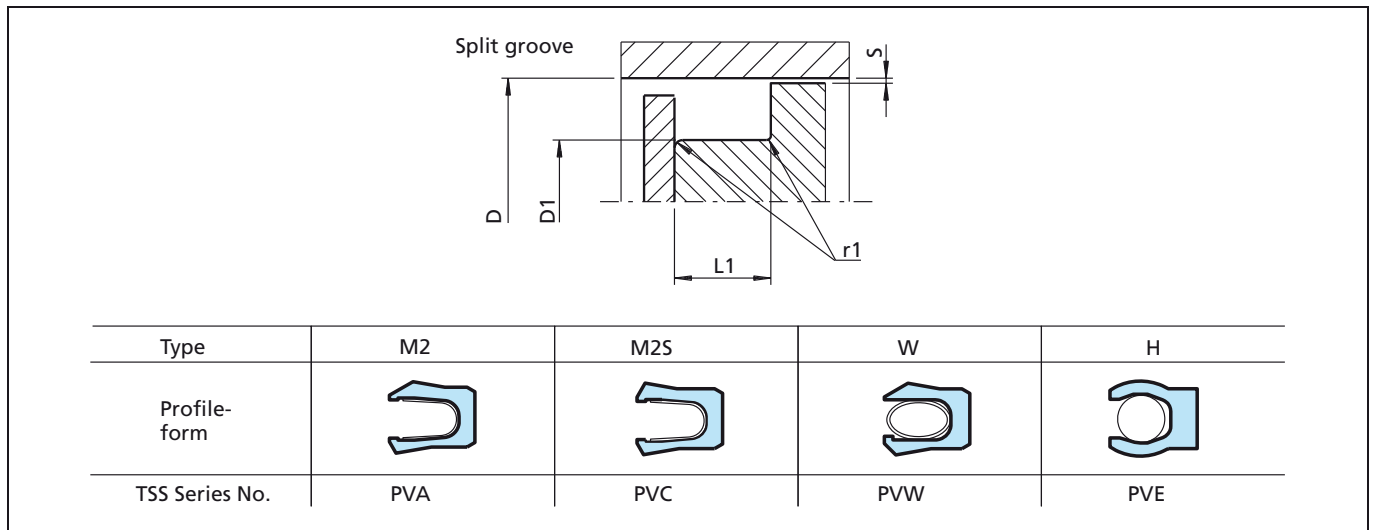

Figure 18 Installation drawing Installation in closed and half-open-groove, see pages 11 - 12

**Table XVII Installation Dimensions**

TSS Series No. for types				Bore Diameter D H9 mm		Groove Diam.	Groove Width	Radius	Radial Clearance <sup>3)</sup> S max.* mm			
M2	M2S	W	H	Standard Range	Extended <sup>1)</sup> Range	D <sub>1</sub> h9 mm	L <sub>1</sub> +0.2 mm	r1max. mm	<2 MPa (20 bar)	<10 MPa (100 bar)	<20 MPa (200 bar)	<40 MPa (400 bar)
-	-	-	PVE5	1000.0 - 2500.0	100.0 - 2500.0	D - 19.0	15.0	0.8	0.90	0.50	0.40	0.20
PVA0	PVC0	PVW0	PVE0	6.0 - 13.9	6.0 - 40.0	D - 2.9	2.4	0.4	0.20	0.10	0.08	0.05
PVA1	PVC1	PVW1	PVE1	14.0 - 24.9	10.0 - 200.0 <sup>2)</sup>	D - 4.5	3.6	0.4	0.25	0.15	0.10	0.07
PVA2	PVC2	PVW2	PVE2	25.0 - 45.9	16.0 - 400.0 <sup>2)</sup>	D - 6.2	4.8	0.6	0.35	0.20	0.15	0.08
PVA3	PVC3	PVW3	PVE3	46.0 - 124.9	28.0 - 700.0 <sup>2)</sup>	D - 9.4	7.1	0.8	0.50	0.25	0.20	0.10
PVA4	PVC4	PVW4	PVE4	125.0 - 630.0	45.0 - 1600.0 <sup>2)</sup>	D - 12.2	9.5	0.8	0.60	0.30	0.25	0.12

\* At pressures > 40 MPa: S max. = H8/f8 reference limit and fits BS EN 20286 - 1 & 2

<sup>1)</sup> Available on request

<sup>2)</sup> For diameters larger than the standard range and for pressures above 40 MPa contact Trelleborg.

<sup>3)</sup> We recommend that the gap dimensions be reduced for temperatures > 80 °C (176 °F)

### Ordering Example

Turcon® Variseal® Type M2, TSS Series No. PVA3 from Table XVII.

Bore diameter: D = 80.0 mm  
 TSS Part No.: PV - 300800  
 (from Table XVIII).

For selection of another seal type, insert the appropriate TSS Series No. at the beginning of the TSS Article Number.

Other materials:  
 Seal ring materials, see page 5, Table III.  
 Spring materials, see page 9, Table IV.

\*\* For diameters ≥ 1000mm multiply only by factor 1.  
 Example: PVE5 for diameter 1200mm.  
 Order number.:PVE5X1200 - T40S.

TSS Article No.	PVA3 0 0800 - T40 S (D)
TSS Series No.	PVA3
Type (Standard)	0
Bore Diameter x 10**	0800
Quality Index (Standard)	-
Material code - Seal ring	T40
Material code - Spring	S
Hi-Clean - (option)	(D)

# Turcon® Variseal® M2, M2S, W and H

Table XVIII Preferred Series / External Sealing

Bore Diameter	Groove Diameter	Groove Width	TSS Part No.
D H9 mm	D <sub>1</sub> h9 mm	L <sub>1</sub> +0.2 mm	
6.0 <b>8.0</b> 10.0	3.1 <b>5.1</b> 7.1	2.4 <b>2.4</b> 2.4	PV_000060 <b>PV_000080</b> PV_000100
<b>12.0</b> 14.0 15.0	<b>9.1</b> 9.5 10.5	<b>2.4</b> 3.6 3.6	<b>PV_000120</b> PV_100140 PV_100150
<b>16.0</b> 18.0 <b>20.0</b>	<b>11.5</b> 13.5 <b>15.5</b>	<b>3.6</b> 3.6 <b>3.6</b>	<b>PV_100160</b> PV_100180 <b>PV_100200</b>
22.0 <b>25.0</b> 28.0	17.5 <b>18.8</b> 21.8	3.6 <b>4.8</b> 4.8	PV_100220 <b>PV_200250</b> PV_200280
30.0 <b>32.0</b> 35.0	23.8 <b>25.8</b> 28.8	4.8 <b>4.8</b> 4.8	PV_200300 <b>PV_200320</b> PV_200350
<b>40.0</b> 42.0 45.0	<b>33.8</b> 35.8 38.8	<b>4.8</b> 4.8 4.8	<b>PV_200400</b> PV_200420 PV_200450
48.0 <b>50.0</b> 52.0	38.6 <b>40.6</b> 42.6	7.1 <b>7.1</b> 7.1	PV_300480 <b>PV_300500</b> PV_300520
55.0 56.0 60.0	45.6 46.6 50.6	7.1 7.1 7.1	PV_300550 PV_300560 PV_300600
<b>63.0</b> 65.0 70.0	<b>53.6</b> 55.6 60.6	<b>7.1</b> 7.1 7.1	<b>PV_300630</b> PV_300650 PV_300700
75.0 <b>80.0</b> 85.0	65.6 <b>70.6</b> 75.6	7.1 <b>7.1</b> 7.1	PV_300750 <b>PV_300800</b> PV_300850
90.0 95.0 <b>100.0</b>	80.6 85.6 <b>90.6</b>	7.1 7.1 <b>7.1</b>	PV_300900 PV_300950 <b>PV_301000</b>
110.0 115.0 120.0	100.6 105.6 110.6	7.1 7.1 7.1	PV_301100 PV_301150 PV_301200
<b>125.0</b> 130.0 135.0	<b>112.8</b> 117.8 122.8	<b>9.5</b> 9.5 9.5	<b>PV_401250</b> PV_401300 PV_401350
140.0 150.0 <b>160.0</b>	127.8 137.8 <b>147.8</b>	9.5 9.5 <b>9.5</b>	PV_401400 PV_401500 <b>PV_401600</b>
170.0 180.0 190.0	157.8 167.8 177.8	9.5 9.5 9.5	PV_401700 PV_401800 PV_401900
<b>200.0</b> 210.0 220.0	<b>187.8</b> 197.8 207.8	<b>9.5</b> 9.5 9.5	<b>PV_402000</b> PV_402100 PV_402200
230.0 240.0 <b>250.0</b>	217.8 227.8 <b>237.8</b>	9.5 9.5 <b>9.5</b>	PV_402300 PV_402400 <b>PV_402500</b>

Bore Diameter	Groove Diameter	Groove Width	TSS Part No.
D H9 mm	D <sub>1</sub> h9 mm	L <sub>1</sub> +0.2 mm	
280.0 300.0 <b>320.0</b>	267.8 287.8 <b>307.8</b>	9.5 9.5 <b>9.5</b>	PV_402800 PV_403000 <b>PV_403200</b>
350.0 <b>400.0</b> 420.0	337.8 <b>387.8</b> 407.8	9.5 <b>9.5</b> 9.5	PV_403500 <b>PV_404000</b> PV_404200
450.0 480.0 <b>500.0</b>	437.8 467.8 <b>487.8</b>	9.5 9.5 <b>9.5</b>	PV_404500 PV_404800 <b>PV_405000</b>

The bore diameters in **bold type** correspond to the recommendations of ISO 3320. Other dimensions and intermediate sizes up to 2500 mm diameter, including imperial (inch) sizes can be supplied.

\*\* For diameters  $\geq 1000$  mm multiply only by factor 1.

Example: PVE5 for diameter 1200 mm. TSS Article No.: PVE5X1200 - T40S.

## Determination of the TSS Article number

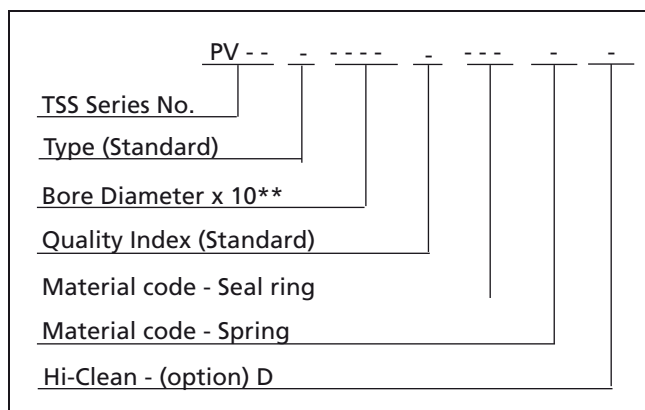

## ■ Turcon® Variseal® HF

### Description

Turcon® Variseal® HF is the standard seal for axial (face) applications. It has the same high sealing load as Variseal® H and is available for both internal and external pressure.

The heavy helical spring in Variseal® HF makes it the best choice for vacuum, gas, and low temperature flange sealing applications.

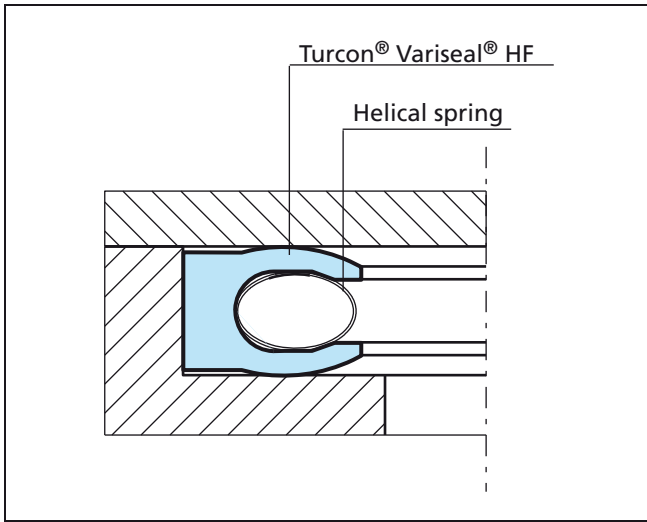

Figure 19 Turcon® Variseal® HF

### Areas of Application

- Compressor housings
- Construction equipment and plant
- Chemical processing
- Crude oil and natural gas installations
- Cryogenic engineering
- Nuclear power
- Aerospace
- Vacuum applications
- Pivot joints

### Advantages

- High sealing pressure
- Excellent sealing integrity in gas and fluid applications
- Withstands rapid changes in temperature
- Good sealing when surfaces are not good
- Easy installation
- Unlimited shelf life

### Technical Data

Operating pressure:	Maximum dynamic load: 40 MPa (400 bar, 5800 psi) Maximum static load: 80 MPa (600 bar, 11603 psi)
Speed:	Static to slow rotating or pivoting movements
Operating temperature:	-200 °C (-328 °F) up to +260 °C (+500 °F)
Media compatibility:	Virtually all fluids, chemicals and gases.
Note:	Consult Trelleborg Sealing Solutions for applications outside these parameters.

### Standard Materials

Jacket:	Material code <b>T05</b>
Spring material:	Spring code <b>S</b> (stainless steel), Material No. 1.4310 (AISI 301)

### Series Designation

For external pressure: **DVL**  
For internal pressure: **DVE**

Our installation recommendations are on pages 24 to 27.

## ■ Installation Recommendations for Turcon® Variseal® HF Flange Seals for Internal Pressure

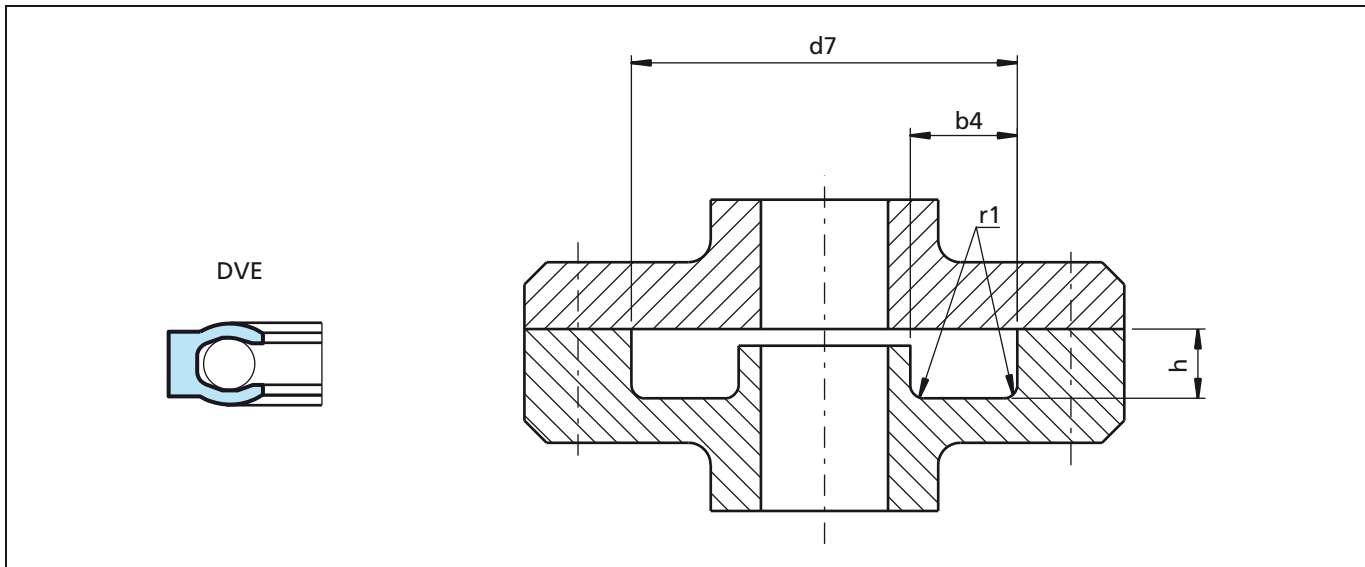

Figure 20 Installation drawing

**Table XIX Installation Dimensions**

TSS Series No.	Groove Outside Diameter $d_7$ H11 mm		Groove Width $b_4$ mm	Groove Depth		Radius $r_1$ mm
	Recommended Range	Extended Range <sup>1)</sup>		min.	h mm	
DVE0	10 - 13.9	10 - 40	2.4	1.45	+0.03	0.4
DVE1	14 - 24.9	13 - 200	3.6	2.25	+0.05	0.4
DVE2	25 - 45.9	18 - 400	4.8	3.10	+0.08	0.6
DVE3	46 - 124.9	28 - 700 <sup>*)</sup>	7.1	4.70	+0.10	0.8
DVE4	125 - 999.9 <sup>**)</sup>	45 - 1000 <sup>**)</sup>	9.5	6.10	+0.15	0.8
DVE5	1000 - 2500.0 <sup>***)</sup>	110 - 2500 <sup>***)</sup>	15.0	9.50	+0.20	0.8

<sup>\*)</sup> For diameters above 600 mm  $b_4$  min. = 8.0 mm

<sup>1)</sup> Available on request

<sup>\*\*)</sup> For diameters above 600 mm  $b_4$  min. = 11.0 mm

<sup>\*\*\*)</sup> For diameters above 1000 mm  $b_4$  min. = 18.0 mm

### Ordering Example

Turcon® Variseal® HF for internal pressure, Series DVE3 (from Table XIX)

Groove outside diameter:  $d_7 = 80.0$  mm

TSS Part No.: DVE300800 (from Table XX)

Materials:

Seal ring materials, see page 5, Table III.

Spring materials, see page 9, Table IV.

<sup>\*\*</sup> For diameters  $\geq 1000$ mm multiply only by factor 1.

Example: DVE5 for diameter 1200mm.

Order number: DVE5X1200 - T40S.

TSS Article No.	DVE3	0	0800	-	T05	S
TSS Series No.						
Type (Standard)						
Groove Out. Diam. x 10 <sup>**</sup>						
Quality Index (Standard)						
Material code - Seal ring						
Material code - Spring						

**Table XX Preferred Series / TSS Part numbers for Internal Pressure**

Groove Outside Diameter	Groove Width	Groove Depth	TSS Part No.
d <sub>7</sub> H11 mm	b <sub>4</sub> mm	h <sup>1)</sup> mm	
10.0 12.0 14.0	2.4 2.4 3.6	1.45 1.45 2.25	DVE000100 DVE000120 DVE100140
15.0 16.0 18.0	3.6 3.6 3.6	2.25 2.25 2.25	DVE100150 DVE100160 DVE100180
20.0 22.0 25.0	3.6 3.6 4.8	2.25 2.25 3.10	DVE100200 DVE100220 DVE200250
28.0 30.0 32.0	4.8 4.8 4.8	3.10 3.10 3.10	DVE200280 DVE200300 DVE200320
35.0 36.0 40.0	4.8 4.8 4.8	3.10 3.10 3.10	DVE200350 DVE200360 DVE200400
42.0 45.0 48.0	4.8 4.8 7.1	3.10 3.10 4.70	DVE200420 DVE200450 DVE300480
50.0 52.0 55.0	7.1 7.1 7.1	4.70 4.70 4.70	DVE300500 DVE300520 DVE300550
56.0 60.0 63.0	7.1 7.1 7.1	4.70 4.70 4.70	DVE300560 DVE300600 DVE300630
65.0 70.0 75.0	7.1 7.1 7.1	4.70 4.70 4.70	DVE300650 DVE300700 DVE300750
80.0 85.0 90.0	7.1 7.1 7.1	4.70 4.70 4.70	DVE300800 DVE300850 DVE300900
95.0 100.0 105.0	7.1 7.1 7.1	4.70 4.70 4.70	DVE300950 DVE301000 DVE301050
110.0 115.0 120.0	7.1 7.1 7.1	4.70 4.70 4.70	DVE301100 DVE301150 DVE301200
122.0 125.0 130.0	7.1 9.5 9.5	4.70 6.10 6.10	DVE301220 DVE401250 DVE401300
135.0 140.0 150.0	9.5 9.5 9.5	6.10 6.10 6.10	DVE401350 DVE401400 DVE401500
160.0 170.0 180.0	9.5 9.5 9.5	6.10 6.10 6.10	DVE401600 DVE401700 DVE401800
190.0 200.0 210.0	9.5 9.5 9.5	6.10 6.10 6.10	DVE401900 DVE402000 DVE402100
220.0 230.0 240.0	9.5 9.5 9.5	6.10 6.10 6.10	DVE402200 DVE402300 DVE402400

Groove Outside Diameter	Groove Width	Groove Depth	TSS Part No.
d <sub>7</sub> H11 mm	b <sub>4</sub> mm	h <sup>1)</sup> mm	
250.0 280.0 300.0	9.5 9.5 9.5	6.10 6.10 6.10	DVE402500 DVE402800 DVE403000
320.0 350.0 360.0	9.5 9.5 9.5	6.10 6.10 6.10	DVE403200 DVE403500 DVE403600
400.0 420.0 450.0	9.5 9.5 9.5	6.10 6.10 6.10	DVE404000 DVE404200 DVE404500
480.0 500.0	9.5 9.5	6.10 6.10	DVE404800 DVE405000

All intermediate sizes up to 500 mm diameter can be supplied. Sizes > 500 mm diameter up to 2500 mm diameter on request.

<sup>1)</sup> Tolerances for groove depth, see Table XIX.

## ■ Installation Recommendations for Turcon® Variseal® HF Flange Seals for External Pressure / Vacuum

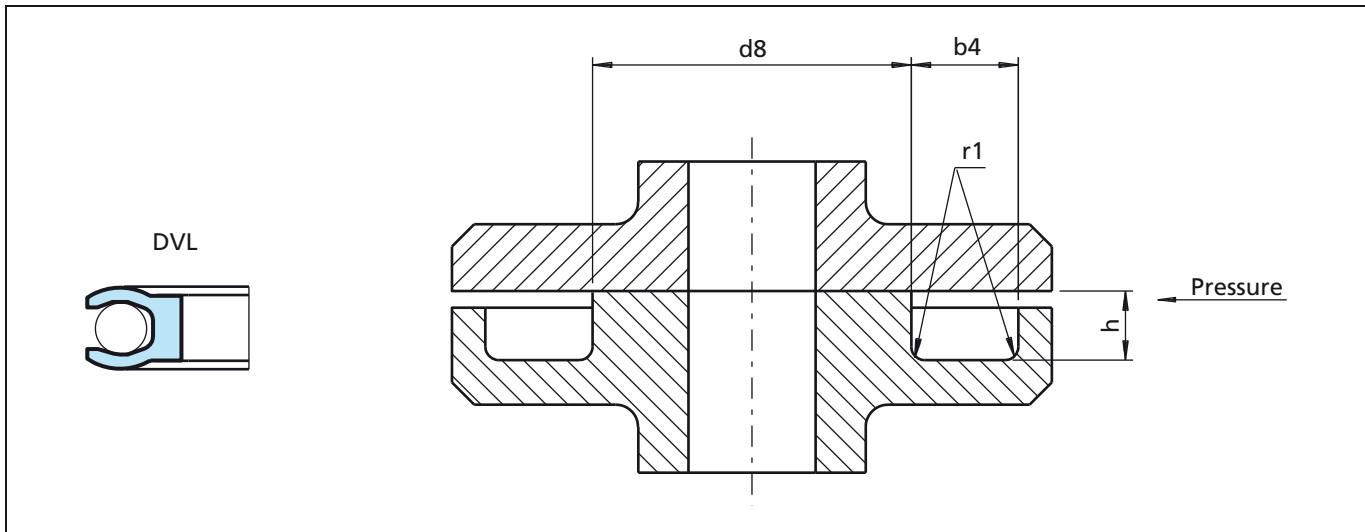

Figure 21 Installation drawing

**Table XXI Installation Dimensions**

TSS Series No.	Groove Inside Diameter $d_8$ H11 mm		Groove Width $b_4$ mm	Groove Depth		Radius $r_1$ mm
	Recommended Range	Extended Range <sup>1)</sup>		h mm	Tol. mm	
DVL0	3 - 9.9	3 - 40	2.4	1.45	+0.03	0.4
DVL1	10 - 19.9	8 - 200	3.6	2.25	+0.05	0.4
DVL2	20 - 39.9	12 - 400	4.8	3.10	+0.08	0.6
DVL3	40 - 119.9	20 - 700 <sup>*)</sup>	7.1	4.70	+0.10	0.8
DVL4	120 - 999.9 <sup>**)</sup>	35 - 1000 <sup>**)</sup>	9.5	6.10	+0.15	0.8
DVL5	1000 - 2500.0 <sup>***)</sup>	80 - 2500 <sup>***)</sup>	15.0	9.50	+0.20	0.8

<sup>\*)</sup> For diameters above 600 mm  $b_4$  min. = 8.0 mm

<sup>1)</sup> Available on request

<sup>\*\*)</sup> For diameters above 600 mm  $b_4$  min. = 11.0 mm

<sup>\*\*\*)</sup> For diameters above 1000 mm  $b_4$  min. = 18.0 mm

### Ordering Example

Turcon® Variseal® HF for external pressure, Series DVL3 (from Table XXI).

Groove inside diameter:  $d_8 = 80.0$  mm

TSS Part No.: DVL300800 (from Table XXII)

Materials:

Seal ring materials, see page 5, Table III.

Spring materials, see page 9, Table IV.

<sup>\*\*</sup> For diameters  $\geq 1000$ mm multiply only by factor 1.

Example: DVL5 for diameter 1200mm.

Order number.: DVL5X1200 - T40S.

TSS Article No.	DVL3	0	0800	-	T05	S
TSS Series No.						
Type (Standard)						
Groove Ins. Diam. x 10 <sup>**</sup>						
Quality Index (Standard)						
Material code - Seal ring						
Material code - Spring						

Table XXII Preferred Series / TSS Part numbers for External Pressure / Vacuum

Groove Inside Diameter	Groove Width	Groove Depth	TSS Part No.
$d_8$ h11 mm	$b_4$ mm	$h^{1)}$ mm	
4.0	2.4	1.4	DVL000040
5.0	2.4	1.4	DVL000050
6.0	2.4	1.4	DVL000060
8.0	2.4	1.4	DVL000080
10.0	3.6	2.2	DVL100100
12.0	3.6	2.2	DVL100120
14.0	3.6	2.2	DVL100140
15.0	3.6	2.2	DVL100150
16.0	3.6	2.2	DVL100160
18.0	3.6	2.2	DVL100180
20.0	4.8	3.1	DVL200200
22.0	4.8	3.1	DVL200220
25.0	4.8	3.1	DVL200250
28.0	4.8	3.1	DVL200280
30.0	4.8	3.1	DVL200300
32.0	4.8	3.1	DVL200320
35.0	4.8	3.1	DVL200350
36.0	4.8	3.1	DVL200360
40.0	7.1	4.7	DVL300400
42.0	7.1	4.7	DVL300420
45.0	7.1	4.7	DVL300450
48.0	7.1	4.7	DVL300480
50.0	7.1	4.7	DVL300500
52.0	7.1	4.7	DVL300520
55.0	7.1	4.7	DVL300550
56.0	7.1	4.7	DVL300560
60.0	7.1	4.7	DVL300600
63.0	7.1	4.7	DVL300630
65.0	7.1	4.7	DVL300650
70.0	7.1	4.7	DVL300700
75.0	7.1	4.7	DVL300750
80.0	7.1	4.7	DVL300800
85.0	7.1	4.7	DVL300850
90.0	7.1	4.7	DVL300900
95.0	7.1	4.7	DVL300950
100.0	7.1	4.7	DVL301000
105.0	7.1	4.7	DVL301050
110.0	7.1	4.7	DVL301100
115.0	7.1	4.7	DVL301150
120.0	9.5	6.1	DVL401200
125.0	9.5	6.1	DVL401250
130.0	9.5	6.1	DVL401300
135.0	9.5	6.1	DVL401350
140.0	9.5	6.1	DVL401400
150.0	9.5	6.1	DVL401500
160.0	9.5	6.1	DVL401600
170.0	9.5	6.1	DVL401700
180.0	9.5	6.1	DVL401800
190.0	9.5	6.1	DVL401900
200.0	9.5	6.1	DVL402000
210.0	9.5	6.1	DVL402100

Groove Inside Diameter	Groove Width	Groove Depth	TSS Part No.
$d_8$ h11 mm	$b_4$ mm	$h^{1)}$ mm	
220.0	9.5	6.1	DVL402200
230.0	9.5	6.1	DVL402300
240.0	9.5	6.1	DVL402400
250.0	9.5	6.1	DVL402500
280.0	9.5	6.1	DVL402800
300.0	9.5	6.1	DVL403000
320.0	9.5	6.1	DVL403200
350.0	9.5	6.1	DVL403500
360.0	9.5	6.1	DVL403600
400.0	9.5	6.1	DVL404000
420.0	9.5	6.1	DVL404200
450.0	9.5	6.1	DVL404500
480.0	9.5	6.1	DVL404800
500.0	9.5	6.1	DVL405000

All intermediate sizes up to 500 mm diameter can be supplied.  
 Sizes > 500 mm diameter up to 2500 mm diameter on request.

<sup>1)</sup> Tolerances for groove depth, see Table XXI.

## ■ Turcon® Roto Variseal®

### Description

Roto Variseal® is excellent in rotary, reciprocating and static applications, when there is a need to lock the seal in the groove.

The standard Variseal® for rotary applications, Turcon® Roto Variseal® is a single acting seal consisting of a U-shaped jacket and a V-shaped corrosion resistant spring.

Roto Variseal® has a flanged heel, which prevents the seal from rotating in the groove and a short heavy dynamic lip that reduces friction. This gives a long service life and good scraping ability, even in media of high viscosity.

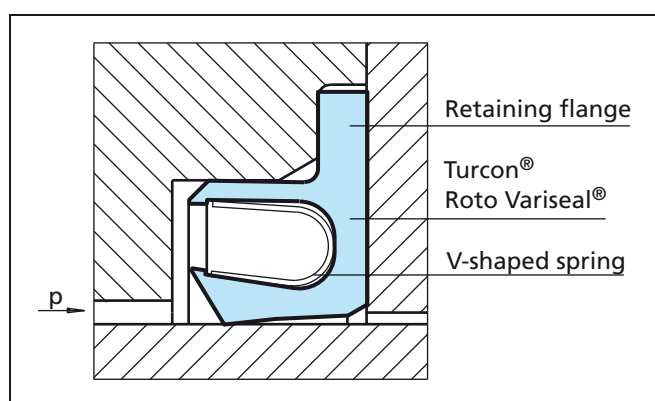

Figure 22 Turcon® Roto Variseal®

### Areas of Application

- Rotary shafts on general hydraulic applications
- Plastic injection molding machines
- Rotating and pivoting arms
- Gearbox shafts

### Advantages

- Suitable for rotary, reciprocating and static applications
- Protects against mechanical torsion
- Low coefficient of friction
- Remains tight in groove even when subject to oscillating or helical movements
- Withstands rapid changes in temperature
- High abrasion resistance
- Excellent resistance to ageing
- Good scraping ability
- Can be sterilized
- Available in Hi-Clean version

### Technical Data

Operating pressure: Maximum dynamic load: 15 MPa (150 bar, 2175 psi)  
Maximum static load: 25 MPa (250 bar, 3626 psi)

Speed: Reciprocating up to 10 m/s (33 ft/sec)  
Rotating up to 2 m/s (6.5 ft/sec)

Temperature: -100 °C (-148 °F) up to +260 °C (+500 °F)

Media compatibility: Virtually all fluids, chemicals and gases

Note: At high temperatures operating pressures and speeds are lower.

### Standard Materials

Jacket: Material compound **T40**

Spring material: Spring code **S** (stainless steel), Material No. 1.4310 (AISI 301)

### Series Designation

Roto Variseal® **TVM**

Our installation recommendations can be found on page 30 and 31.

## Frictional Force

Indicative values for frictional force are included in Figure 23. Frictional force is given as a function of sliding speed and operating pressure for a shaft diameter of 50 mm (2 inches) at an oil temperature of 60 °C (140 °F). The operating limits are lower at higher temperatures.

Indicative values for other shaft diameters can be calculated from the formula:

$$P \cong P_{50} \times \left( \frac{d}{50 \text{ mm}} \right) \text{ [W]}$$

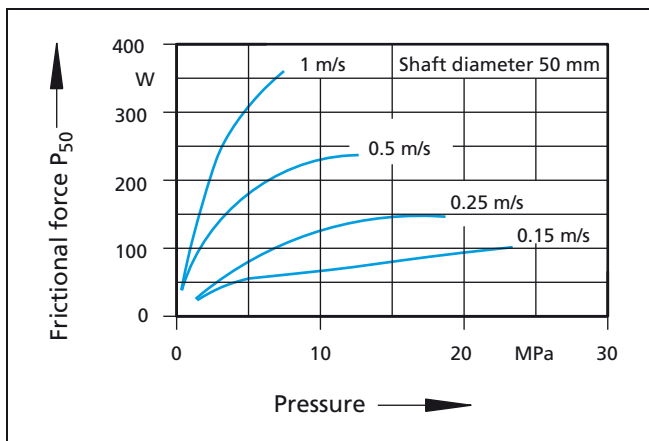

Figure 23 Frictional Force for Turcon® Roto Variseal®

The indicative values apply for constant operating conditions. Changes in these, such as pressure fluctuations or direction of rotation can result in significantly higher frictional values.

## Application Limits

The maximum operating limits for temperature, pressure and speed are dependent upon one another and therefore cannot all apply at the same time.

The lubrication properties of the media to be sealed and heat dissipation must also be taken into consideration.

The following pv values can be used as general guidelines:

- Poor lubrication up to pv = 2 MPa x m/s
- Good lubrication up to pv = 5 MPa x m/s
- Very good cooling up to pv = 8 MPa x m/s

These values are lower for diameters < 50 mm (2 inches). Tests of these characteristics are recommended to establish application limits.

## Mating Surface Materials

Sealing of applications with rotating movements require very good mating surfaces. A minimum hardness 55 HRC is recommended to a hardening depth of at least 0.3 mm.

Particular attention must be paid to coated surfaces and good heat dissipation through the coating is required.

Note: Table XIII on page 12 gives permissible eccentricity for Turcon® Roto Variseal®.

## ■ Installation Recommendation for Turcon® Roto Variseal®

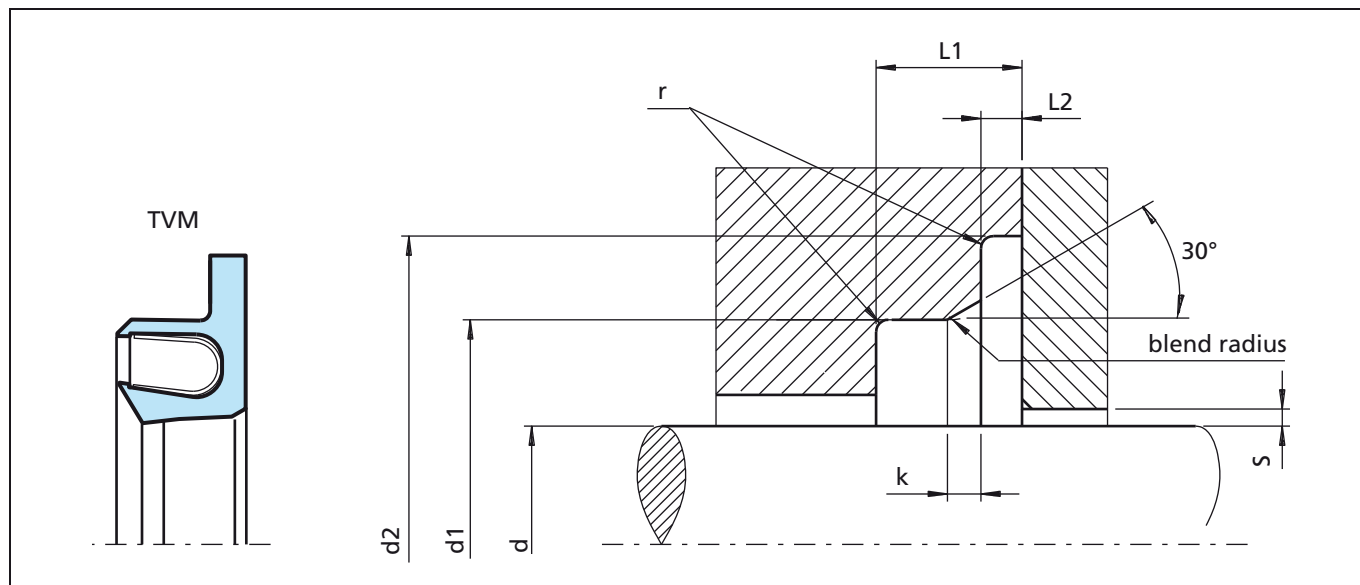

Figure 24 Installation drawing

**Table XXIII Installation Dimensions**

TSS Series No.	Rod Diameter d f8/h9 mm		Groove Diameter		Groove Width		Lead-in Chamfer k mm	Radius r max. mm	Radial Clearance S max. mm		
	Standard Range	Extended <sup>1)2)</sup> Range	d1 H9 mm	d2 H10 mm	L1 min mm	L2 mm			<2 MPa (20 bar)	<10 MPa (100 bar)	<20 MPa (200 bar)
TVM1	5.0 - 19.9	20.0 - 200.0	d + 5.0	d + 9.0	3.6	0.85 <sub>+0 / -0.1</sub>	0.8	0.3	0.25	0.15	0.10
TVM2	20.0 - 39.9	10.0 - 400.0	d + 7.0	d + 12.5	4.8	1.35 <sub>+0 / -0.15</sub>	1.1	0.4	0.35	0.20	0.15
TVM3	40.0 - 399.9	20.0 - 700.0	d + 10.5	d + 17.5	7.1	1.80 <sub>+0 / -0.20</sub>	1.4	0.5	0.50	0.25	0.20
TCM4	400.0 - 999.9	35.0 - 999.9	d + 14.0	d + 22.0	9.5	2.80 <sub>+0 / -0.20</sub>	1.6	0.5	0.60	0.30	0.25

<sup>1)</sup> Available on request    <sup>2)</sup> For diameters larger than the standard range contact Trelleborg

### Ordering Example

Turcon® Roto Variseal®, standard series TVM3 (from Table XXIII).

Rod diameter: d = 80.0 mm

TSS Part No. TVM300800 (from Table XXIV)

Materials:

Seal ring materials, see page 5, Table III.

Spring materials, see page 9, Table IV.

Installation instructions, see page 12

\*\* For diameters ≥ 1000mm multiply only by factor 1.

Example: TVM4 for diameter 1200mm.

Order number: TVM4X1200 - T40S.

TSS Article No.	TVM3	0	0800	-	T40	S	(D)
TSS Series No.							
Type (Standard)							
Rod Diameter x 10**							
Quality Index (Standard)							
Material code - Seal ring							
Material code - Spring							
Hi-Clean - (option)							

**Table XXIV Preferred Series / TSS Part numbers for Turcon® Roto Variseal®**

Rod Diameter	Groove Diameter	Groove Width	TSS Part No.
d f8/h9 mm	d <sub>1</sub> H9 mm	L <sub>1</sub> min. mm	
<b>5.0</b>	<b>10.0</b>	<b>3.6</b>	<b>TVM100050</b>
<b>6.0</b>	<b>11.0</b>	<b>3.6</b>	<b>TVM100060</b>
<b>8.0</b>	<b>13.0</b>	<b>3.6</b>	<b>TVM100080</b>
<b>10.0</b>	<b>15.0</b>	<b>3.6</b>	<b>TVM100100</b>
<b>12.0</b>	<b>17.0</b>	<b>3.6</b>	<b>TVM100120</b>
<b>14.0</b>	<b>19.0</b>	<b>3.6</b>	<b>TVM100140</b>
15.0	20.0	3.6	TVM100150
<b>16.0</b>	<b>21.0</b>	<b>3.6</b>	<b>TVM100160</b>
<b>18.0</b>	<b>23.0</b>	<b>3.6</b>	<b>TVM100180</b>
<b>20.0</b>	<b>27.0</b>	<b>4.8</b>	<b>TVM200200</b>
<b>22.0</b>	<b>29.0</b>	<b>4.8</b>	<b>TVM200220</b>
<b>25.0</b>	<b>32.0</b>	<b>4.8</b>	<b>TVM200250</b>
<b>28.0</b>	<b>35.0</b>	<b>4.8</b>	<b>TVM200280</b>
30.0	37.0	4.8	TVM200300
<b>32.0</b>	<b>39.0</b>	<b>4.8</b>	<b>TVM200320</b>
35.0	42.0	4.8	TVM200350
<b>36.0</b>	<b>43.0</b>	<b>4.8</b>	<b>TVM200360</b>
<b>40.0</b>	<b>50.5</b>	<b>7.1</b>	<b>TVM300400</b>
42.0	52.5	7.1	TVM300420
<b>45.0</b>	<b>55.5</b>	<b>7.1</b>	<b>TVM300450</b>
48.0	58.5	7.1	TVM300480
<b>50.0</b>	<b>60.5</b>	<b>7.1</b>	<b>TVM300500</b>
52.0	62.5	7.1	TVM300520
55.0	65.5	7.1	TVM300550
<b>56.0</b>	<b>66.5</b>	<b>7.1</b>	<b>TVM300560</b>
60.0	70.5	7.1	TVM300600
<b>63.0</b>	<b>73.5</b>	<b>7.1</b>	<b>TVM300630</b>
65.0	75.5	7.1	TVM300650
<b>70.0</b>	<b>80.5</b>	<b>7.1</b>	<b>TVM300700</b>
75.0	85.5	7.1	TVM300750
<b>80.0</b>	<b>90.5</b>	<b>7.1</b>	<b>TVM300800</b>
85.0	95.5	7.1	TVM300850
<b>90.0</b>	<b>100.5</b>	<b>7.1</b>	<b>TVM300900</b>
95.0	105.5	7.1	TVM300950
<b>100.0</b>	<b>110.5</b>	<b>7.1</b>	<b>TVM301000</b>
105.0	115.5	7.1	TVM301050
<b>110.0</b>	<b>120.5</b>	<b>7.1</b>	<b>TVM301100</b>
115.0	125.5	7.1	TVM301150
120.0	130.5	7.1	TVM301200
<b>125.0</b>	<b>135.5</b>	<b>7.1</b>	<b>TVM301250</b>
130.0	140.5	7.1	TVM301300
135.0	145.5	7.1	TVM301350
<b>140.0</b>	<b>150.5</b>	<b>7.1</b>	<b>TVM301400</b>
150.0	160.5	7.1	TVM301500
<b>160.0</b>	<b>170.5</b>	<b>7.1</b>	<b>TVM301600</b>
170.0	180.5	7.1	TVM301700
<b>180.0</b>	<b>190.5</b>	<b>7.1</b>	<b>TVM301800</b>
190.0	200.5	7.1	TVM301900
<b>200.0</b>	<b>210.5</b>	<b>7.1</b>	<b>TVM302000</b>
210.0	220.5	7.1	TVM302100
<b>220.0</b>	<b>230.5</b>	<b>7.1</b>	<b>TVM302200</b>

Rod Diameter	Groove Diameter	Groove Width	TSS Part No.
d f8/h9 mm	d <sub>1</sub> H9 mm	L <sub>1</sub> min. mm	
230.0	240.5	7.1	TVM302300
240.0	250.5	7.1	TVM302400
<b>250.0</b>	<b>260.5</b>	<b>7.1</b>	<b>TVM302500</b>
<b>280.0</b>	<b>290.5</b>	<b>7.1</b>	<b>TVM302800</b>
300.0	310.5	7.1	TVM303000
<b>320.0</b>	<b>330.5</b>	<b>7.1</b>	<b>TVM303200</b>
350.0	360.5	7.1	TVM303500
<b>360.0</b>	<b>370.5</b>	<b>7.1</b>	<b>TVM303600</b>
400.0	414.0	9.5	TVM404000
420.0	434.0	9.5	TVM404200
450.0	464.0	9.5	TVM404500
480.0	494.0	9.5	TVM404800
500.0	514.0	9.5	TVM405000
600.0	614.0	9.5	TVM406000
700.0	714.0	9.5	TVM407000

The rod diameters in **bold type** correspond to the recommendations of ISO 3320.

Other dimensions and intermediate sizes up to 2500 mm diameter, including imperial (inch) sizes can be supplied.

## ■ Special Types

### Turcon® Variseal® Hi-Clean

Turcon® Variseal® M2, M2S and Roto Variseal® are available with the spring groove filled with high temperature silicone. Extremely important in food and pharmaceutical processing, this prevents trapping of contaminants within the seal, making it easier to clean.

Variseal® Hi-Clean is also ideal for dirty environments where it may be in contact with mud, slurry or sand. In these applications, the silicone maintains the flexibility of the spring and seal lips.

### Advantages

- No dead space
- Can be sterilized easily
- Silicone compound increases sealing pressure

When ordering Variseal® Hi-Clean, add the letter **D** to the end of the material code.

### Turcon® Variseal® with Extended Heel

All Turcon® Variseal® types except the Turcon® Roto Variseal® can be supplied with an extended heel as an alternative to existing O-Ring groove versions, with or without back-up ring (Figure 26 + 27).

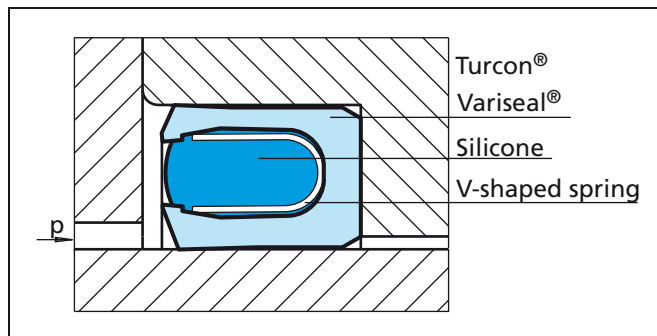

Figure 25 Turcon® Variseal® Hi-Clean

### TSS Article Number Example

RVC200350 - T40SD

This version is recommended also for high-pressure applications or when the extrusion gap is larger than prescribed.

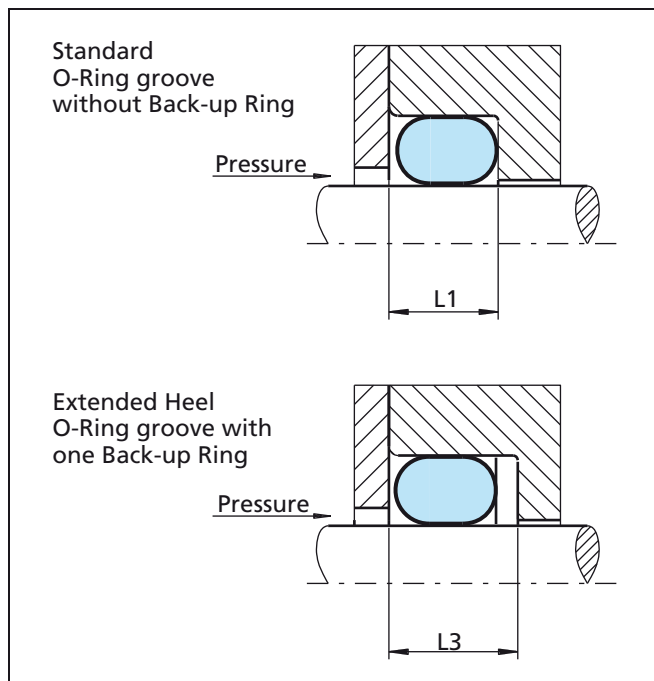

Figure 26 Standard O-Ring groove without and with Back-up Ring

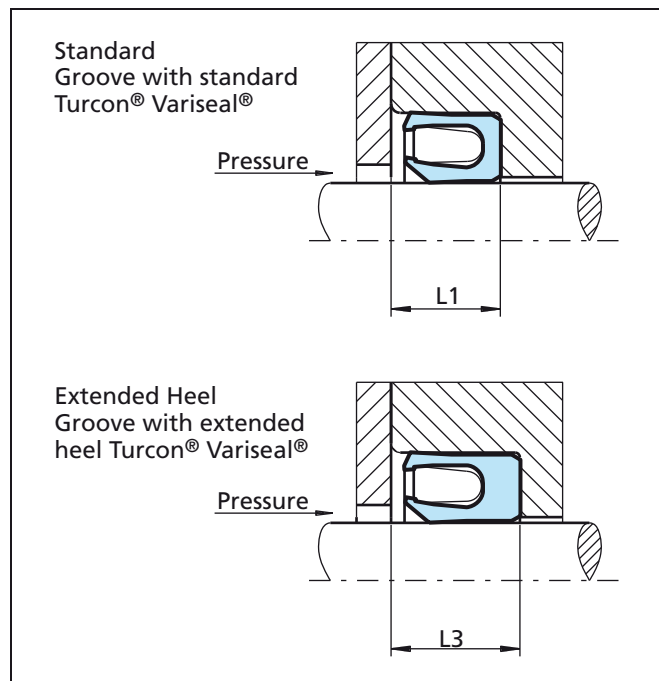

Figure 27 Standard Turcon® Variseal® and Turcon® Variseal® with extended heel

**Table XXV Groove Widths**

Series No. Rod Piston	Groove Width	
	L <sub>1</sub> mm	L <sub>3</sub> mm
RV_0 PV_0	2.40	3.80
RV_1 PV_1	3.60	4.65
RV_2 PV_2	4.80	5.70
RV_3 PV_3	7.10	8.50
RV_4 PV_4	9.50	11.20
RV_5 PV_5	15.00	20.00

Groove widths for standard grooves L<sub>1</sub> and grooves with one Back-up Ring to L<sub>3</sub>.

**Table XXVI Determining the TSS Article Number**

Turcon Variseal® Types	Standard Rod/Piston	With Extended Heel Rod/Piston
Turcon Variseal® M2	RVA/PVA	RVB/PVB
Turcon Variseal® M2S	RVC/PVC	RVD/PVD
Turcon Variseal® W	RVW/PVW	RVX/PVX
Turcon Variseal® H	RVE/PVE	RVF/PVF
Turcon Variseal® HF	DVE/DVL	DVF/DVN

When ordering the above seal types, use the first two letters of the standard TSS Article Number and replace the third letter as shown in Table XXVI.

### TSS Article Number Example

RVB200350-T40S

A wide range of special and customized Variseal® designs are available. These may be slight modification to standard designs or a completely new configuration, if required.

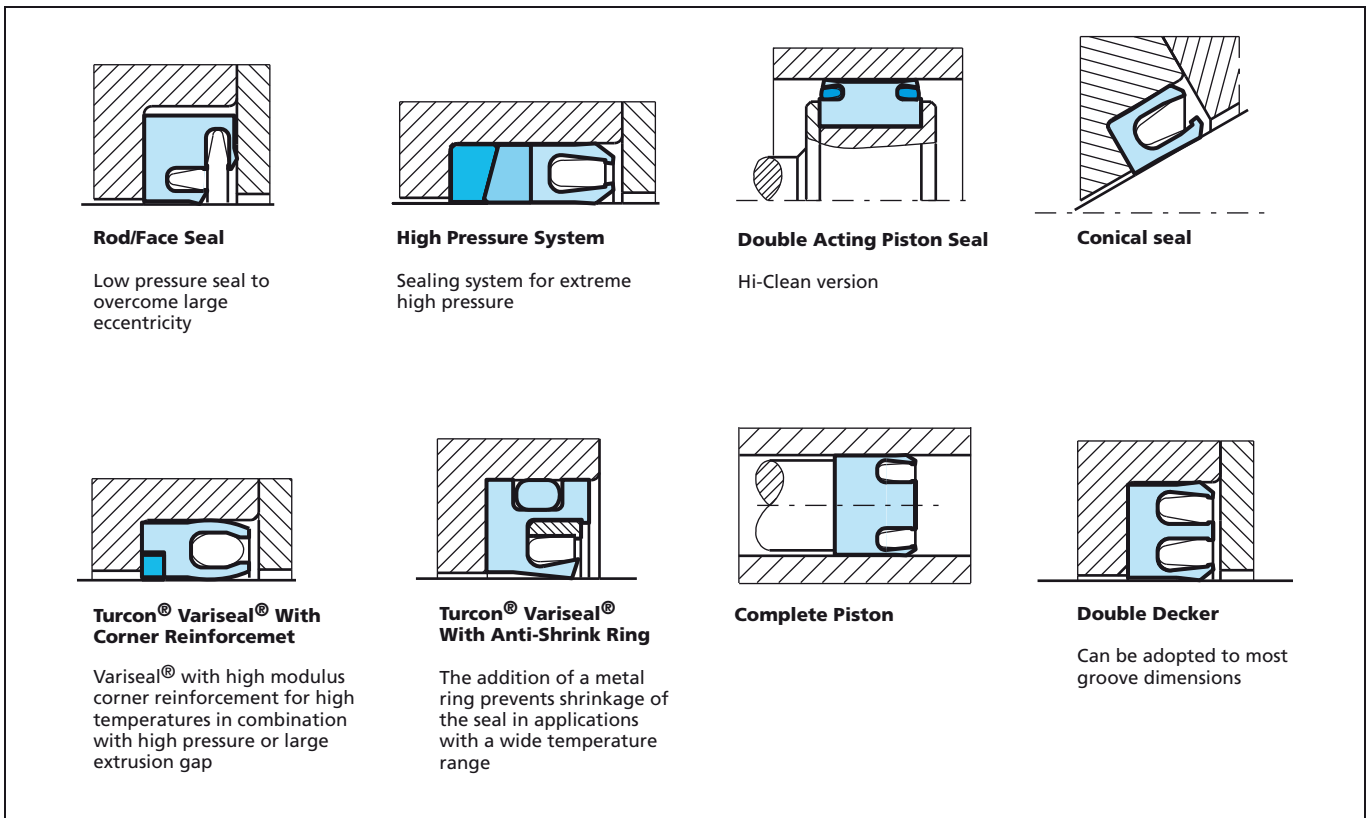

Figure 28 Customized designs

## ■ Storage Instructions

If seals and bearings are stored, the following guidelines should be followed to optimize their storage life.

- Do not store seals in a deformed condition
- Store dry under normal atmospheric conditions (65% relative moisture  $\pm$ 10%)
- Ideal temperature for storage is between +5 °C and +25 °C (41 °F and 77 °F)
- Exposure to heat, moisture, light, oxygen, ozone and liquids can have a detrimental effect on performance characteristics of some materials
- Direct contact with heat sources should be avoided
- Ensure seals cannot be physically damaged by anything within the storage area
- Keep in the original sealed packaging

# Conversion Tables

**Table XXVII SI - Basic Units**

Measures	Units	Symbol
Length	Metre	m
Mass	Kilogram	kg
Time	Second	s

**Table XXIX Length**

	inch	foot	yard	mm	metre
1 inch =		0.0833	0.0278	25.4	0.0254
1 foot =	12		0.333	304.8	0.3048
1 yard =	36	3		914.4	0.9144
1 mm =	0.03937	0.0033	0.00109		0.001
1 metre =	39.37	3.2808	1.0936	1,000	

**Table XXX Torque**

	inch-ounce	inch-pound	foot-pound	kg-metre	Newton-metre
1 inch-ounce =		0.0625	0.0052	$7.2 \times 10^{-4}$	$7.06 \times 10^{-3}$
1 inch-pound =	16		0.0833	$1.152 \times 10^{-2}$	0.1130
1 foot-pound =	192	12		0.1383	1.356
1 kg-metre =	1,388.7	86.796	7.233		9.80665
1 Newton-metre =	141.6	8.850	0.7375	0.1020	

**Table XXXI Area**

	inch <sup>2</sup>	foot <sup>2</sup>	yard <sup>2</sup>	mm <sup>2</sup>	m <sup>2</sup>
1 inch <sup>2</sup> =		0.0069	0.00077	645.16	$6.45 \times 10^{-4}$
1 foot <sup>2</sup> =	144		0.111	92,903	0.0929
1 yard <sup>2</sup> =	1,296	9		836,100	0.8361
1 mm <sup>2</sup> =	0.0016	$1.0764 \times 10^{-5}$	$1.196 \times 10^{-6}$		$10^{-6}$
1 m <sup>2</sup> =	1,550	10.764	1.196	$10^6$	

**Table XXXII Volume**

	inch <sup>3</sup>	US quart	imp. gallon	foot <sup>3</sup>	US gallon	liter
1 inch <sup>3</sup> =		0.0173	0.0036	0.00058	0.0043	0.0164
1 US quart =	57.75		0.2082	0.0334	0.25	0.9464
1 imp. gallon =	277	4.8		0.1604	1.2	4.546
1 foot <sup>3</sup> =	1,728	29.922	6.23		7.48	28.317
1 US gallon =	231	4	0.8327	0.1337		3.785
1 liter =	61.024	1.0567	0.220	0.0353	0.264	

**Table XXXVIII Pressure**

	inch Hg	psi	atmosphere	torr	mm Hg	bar	MPa	kg/cm <sup>2</sup>
1 inch Hg =		0.491	0.0334	25.4	25.4	0.0339	0.00339	0.0345
1 psi =	2.036		0.0680	51.715	51.715	0.0689	0.00689	0.0703
1 atmosphere =	29.921	14.696		760	760	1.0133	0.10133	1.0332
1 torr =	0.0394	0.0193	0.0013		1	0.0013	0.00013	0.00136
1 mm Hg =	0.0394	0.0193	0.0013	1		0.0013	0.00013	0.00136
1 bar =	29.53	14.504	0.987	749.87	749.87		0.1	1.020
1 MPa =	295.3	145.04	9.869	7498.7	7498.7	10		10.2
1 kg/cm <sup>2</sup> =	28.950	14.22	0.968	735.35	735.35	0.980	0.098	

Measures	Units	Symbol
Electric current	Ampere	A
Temperature	Kelvin	K
Luminous intensity	Candela	cd
Amount of substance	Mol	mol

**Table XXXIII Temperature**

	°K (Kelvin)	°C	°F
°K =		°C + 273.15	(°F - 459.67) 5/9
°C =	°K - 273.15		(°F - 32) 5/9
°F =	°K 9/5 - 459.67	°C 9/5 + 32	

**Table XXXIV Density**

	ounce/inch <sup>3</sup>	pound/foot <sup>3</sup>	g/cm <sup>3</sup>
1 ounce/inch <sup>3</sup> =		108	1.73
1 pound/foot <sup>3</sup> =	0.0092		0.016
1 g/cm <sup>3</sup> =	0.578	62.43	

**Table XXXV Force**

	Newton (N)	kilopond (kp)	pound force
1 Newton (N) =		0.10197	0.22481
1 kilopond (kp) =	9.80665		2.20463
1 pound force =	4.4482	0.45359	

**Table XXXVI Velocity (Speed)**

	foot/s	foot/min	mile/hour	metre/s	km/hour
1 foot/s =		60	0.6818	0.3048	1.097
1 ft/min =	0.017		0.0114	0.00508	0.01829
1 mile/hour =	1.4667	88		0.447	1.609
1 metre/s =	3.280	196.848	2.237		3.6
1 km/h =	0.9113	54.68	0.6214	0.278	

**Table XXXVII Mass**

	ounce	pound	kg
1 ounce =		0.0625	0.0283
1 pound =	16		0.4536
1 kg =	35.274	2.2046	



**Contact your local marketing company for further information:**

<b>Europe</b>	<b>Telephone</b>	<b>Americas</b>	<b>Telephone</b>
<b>AUSTRIA - Vienna</b> <small>(ALBANIA, BOSNIA AND HERZEGOVINA, MACEDONIA, SERBIA AND MONTENEGRO, SLOVENIA)</small>	+43 (0) 1 406 47 33	<b>AMERICAS - REGIONAL</b>	+1 260 749 9631
<b>BELGIUM - Dion-Valmont</b> <small>(LUXEMBOURG)</small>	+32 (0) 10 22 57 50	<b>BRAZIL - São Paulo</b>	+55 11 3372 4500
<b>BULGARIA - Sofia</b> <small>(ROMANIA)</small>	+359 (0)2 969 95 99	<b>CANADA - Etobicoke, ON</b>	+1 416 213 9444
<b>CROATIA - Zagreb</b>	+385 (0) 1 24 56 387	<b>MEXICO - Mexico City</b>	+52 55 57 19 50 05
<b>CZECH REPUBLIC - Rakovnik</b> <small>(SLOVAKIA)</small>	+420 313 529 111	<b>USA, East - Conshohocken, PA</b>	+1 610 828 3209
<b>DENMARK - Hillerød</b>	+45 48 22 80 80	<b>USA, Great Lakes - Fort Wayne, IN</b>	+1 260 482 4050
<b>FINLAND - Vantaa</b> <small>(ESTONIA, LATVIA)</small>	+358 (0) 207 12 13 50	<b>USA, Midwest - Lombard, IL</b>	+1 630 268 9915
<b>FRANCE - Maisons-Laffitte</b>	+33 (0) 1 30 86 56 00	<b>USA, Mountain - Broomfield, CO</b>	+1 303 469 1357
<b>GERMANY - Stuttgart</b>	+49 (0) 711 7864 0	<b>USA, Northern California - Fresno, CA</b>	+1 559 449 6070
<b>GREECE</b>	+41 (0) 21 631 41 11	<b>USA, Northwest - Portland, OR</b>	+1 503 595 6565
<b>HUNGARY - Budaörs</b>	+36 (06) 23 50 21 21	<b>USA, South - N. Charleston, SC</b>	+1 843 747 7656
<b>ITALY - Livorno</b>	+39 0586 22 6111	<b>USA, Southwest - Houston, TX</b>	+1 713 461 3495
<b>THE NETHERLANDS - Barendrecht</b>	+31 (0) 10 29 22 111	<b>USA, West - Torrance, CA</b>	+1 310 371 1025
<b>NORWAY - Oslo</b>	+47 22 64 60 80		
<b>POLAND - Warsaw</b> <small>(LITHUANIA, UKRAINE, BELARUS)</small>	+48 (0) 22 863 30 11	<b>Asia Pacific</b>	<b>Telephone</b>
<b>RUSSIA - Moscow</b>	+7 495 982 39 21	<b>ASIA PACIFIC REGIONAL</b>	+65 6 577 1778
<b>SPAIN - Madrid</b> <small>(PORTUGAL)</small>	+34 (0) 91 71057 30	<b>CHINA - Hong Kong</b>	+852 2366 9165
<b>SWEDEN - Jönköping</b>	+46 (0) 36 34 15 00	<b>CHINA - Shanghai</b>	+86 (0) 21 6145 1830
<b>SWITZERLAND - Crissier</b>	+41 (0) 21 631 41 11	<b>INDIA - Bangalore</b>	+91 (0) 80 2245 5157
<b>TURKEY</b>	+41 (0) 21 631 41 11	<b>JAPAN - Tokyo</b>	+81 (0) 3 5633 8008
<b>UNITED KINGDOM - Solihull</b> <small>(EIRE)</small>	+44 (0) 121 744 1221	<b>KOREA - Anyang</b>	+82 (0) 31 386 3283
<b>AFRICA REGIONAL</b>	+41 (0) 21 631 41 11	<b>MALAYSIA - Kuala Lumpur</b>	+60 (0) 3 9059 6388
<b>MIDDLE EAST REGIONAL</b>	+41 (0) 21 631 41 11	<b>TAIWAN - Taichung</b>	+886 4 2382 8886
		<b>THAILAND - Bangkok</b>	+66 (0) 2732-2861
		<b>SINGAPORE</b>	
		<b>and all other countries in Asia</b>	+65 6 577 1778

[www.tss.trelleborg.com](http://www.tss.trelleborg.com)

