

Radial Oil Seals

Typ TRJ/TRL

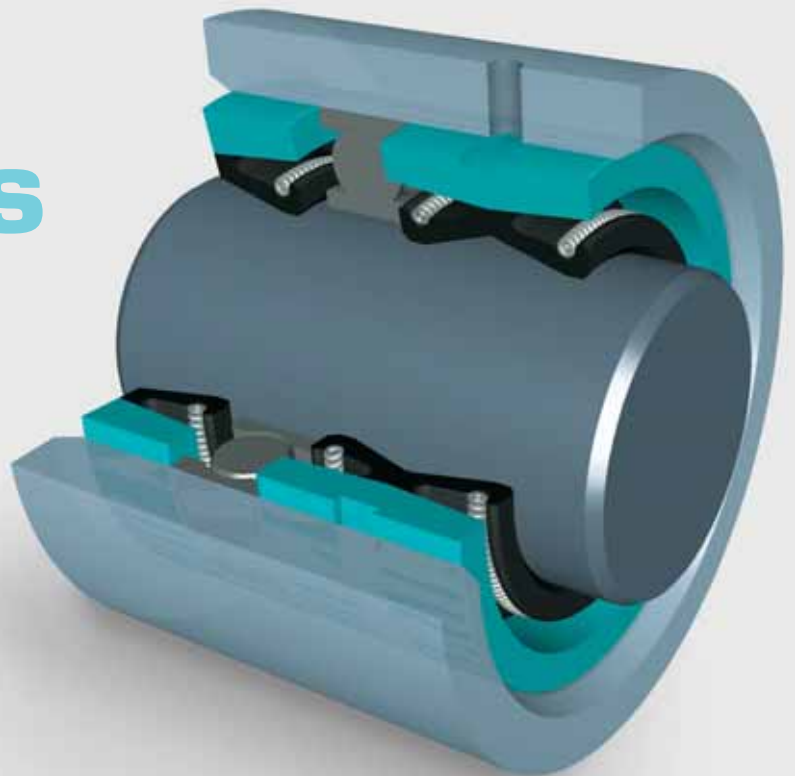

Your Partner for Sealing Technology



Your Partner for Sealing Technology

Trelleborg Sealing Solutions is a major international sealing force, uniquely placed to offer dedicated design and development from our market-leading product and material portfolio: a one-stop-shop providing the best in elastomer, thermoplastic, PTFE and composite technologies for applications in aerospace, industrial and automotive industries.

With 50 years of experience, Trelleborg Sealing Solutions engineers support customers with design, prototyping, production, test and installation using state-of-the-art design tools. An international network of over 70 facilities worldwide includes 30 manufacturing sites, strategically positioned research and development centers, including materials and development laboratories and locations specializing in design and applications.

Developing and formulating materials in-house, we utilize the resource of our material database, including over 2,000 proprietary compounds and a range of unique products.

Trelleborg Sealing Solutions fulfills challenging service requirements, supplying standard parts in volume or a single custom-manufactured component, through our integrated logistical support, which effectively delivers over 40,000 sealing products to customers worldwide.

Facilities are certified to ISO 9001:2000 and ISO/TS 16949:2002. Trelleborg Sealing Solutions is backed by the experiences and resources of one of the world's foremost experts in polymer technology: the Trelleborg Group.

ISO 9001:2000

ISO/TS 16949:2002

The information in this brochure is intended to be for general reference purposes only and is not intended to be a specific recommendation for any individual application. The application limits for pressure, temperature, speed and media given are maximum values determined in laboratory conditions. In application, due to the interaction of operating parameters, maximum values may not be achieved. It is vital therefore, that customers satisfy themselves as to the suitability of product and material for each of their individual applications. Any reliance on information is therefore at the user's own risk. In no event will Trelleborg Sealing Solutions be liable for any loss, damage, claim or expense directly or indirectly arising or resulting from the use of any information provided in this brochure. While every effort is made to ensure the accuracy of information contained herewith, Trelleborg Sealing Solutions cannot warrant the accuracy or completeness of information.

To obtain the best recommendation for a specific application, please contact your local Trelleborg Sealing Solutions marketing company.

This edition supersedes all previous brochures.
This brochure or any part of it may not be reproduced without permission.

© All trademarks are the property of Trelleborg Group.
The turquoise color is a registered trademark of Trelleborg Group.
© 2008, Trelleborg Group. All rights reserved.



■ Description

Fibre reinforced oil seals for large diameter

Fibre reinforced oil seals contain no metal parts with the exception of the spring. Instead of the metal insert, a reinforced fibre component is moulded into the body of the seal. Damage through transport and mounting is consequently excluded.

Fibre reinforced oil seals are mainly used for installation in constructions and equipment with large diameters.

The use of an axial retaining plate is necessary except for the type TRJ/F and respectively for the type TRL/F. See figure 7.

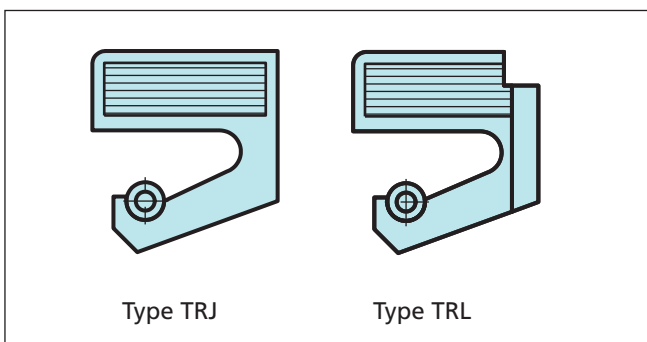

Figure 1 Fibres reinforced design for large diameters

Split version

To ease the mounting or in case of repair the types TRJ and TRL are also available in split version.

To ensure effective sealing at the split ends, a full rubber section is moulded at the join so that contact between homogeneous elastic surfaces maximises the sealing effect. See figure 1a.

The interface should always be above the oil level.

If two seals in split version are mounted together, the interface should be turned a minimum of 30° to the side.

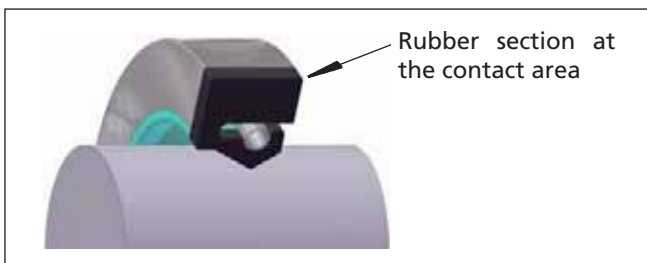

Figure 1a

Separation of two media with type TRL

A single oil seal should not be used for the separation of two Media.

In such cases two seals are fitted in a back to back arrangement. The type TRL is suitable for the sealing of large diameters. It is a special design with peripheral and radial grooves where a lubricant could be applied.

The peripheral groove on the seal reduces the need to cut a groove in the housing. See figure 2: Type TRL mounted back to back.

The seal can be used for:

- Isolation of two media
- If a lubrication is necessary from the outside

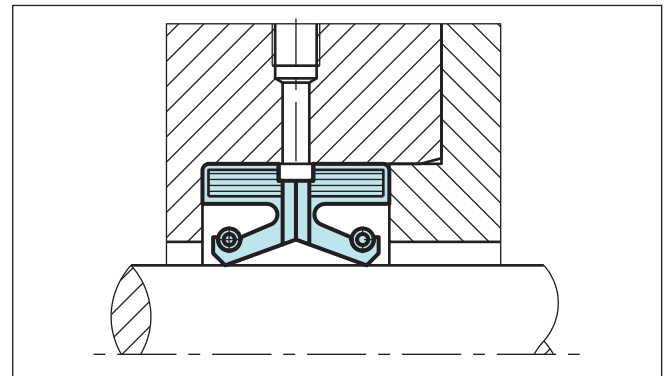

Figure 2 Type TRL mounted back to back

Special design TRJ/F and TRL/F with reinforced shoulder

Whenever a retaining plate cannot be fitted we can supply a seal made in a special hardened compound namely type TRJ/F and TRL/L, which makes the seal self-retaining and providing effective sealing also at the O.D.

Trelleborg Sealing Solutions type TRJ/F and TRL/F are supplied in standard form and are not available in split version. See figure 3.

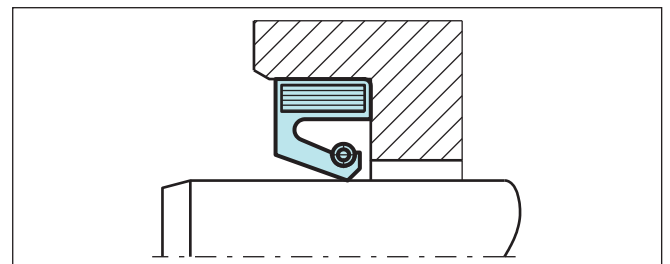

Figure 3 Type TRJ/F mounted without axial retaining plate



Design Instructions

Installation on the shaft

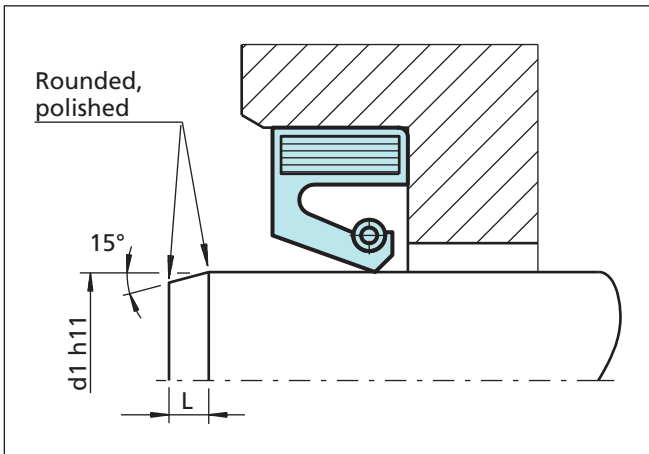

Figure 4 Installation of the oil seal

To facilitate the installation of the seal with minimum risk of lip damage, the shaft should have a 15° chamfer with length "L" as function of its diameter "d1" as indicated in figure 5.

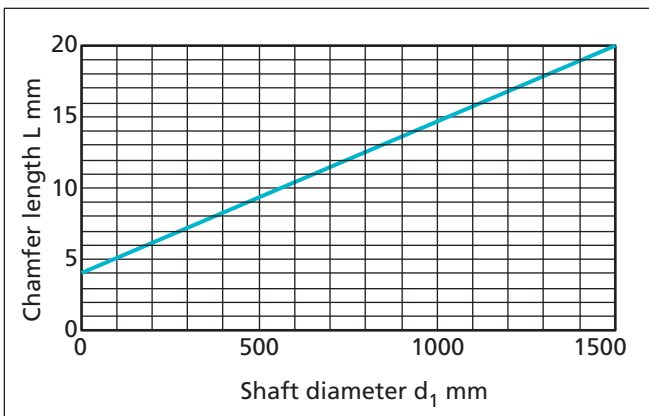

Figure 5 Chamfer length as function of the shaft diameter

Eccentricity

Eccentricity between shaft and housing bore centers should be avoided in order to eliminate unilateral load of the lip. See table I.

Table I Static Eccentricity

| d ₁ | b x f (mm) | max. stat. Ecc. (mm) |
|----------------|------------|----------------------|
| 100 - 250 | 16 x 20 | 0.50 |
| 250 - 400 | 20 x 22 | 0.55 |
| 400 - 600 | 22 x 25 | 0.62 |
| >600 | 25 x 32 | 0.70 |

Shaft run out

Shaft run out should be avoided or kept within a minimum. At higher speeds there is a risk that the inertia of the sealing lip prevents it from following the shaft movement. The seal must be located next to the bearing and the bearing play be maintained at the minimum value possible. See figure 6.

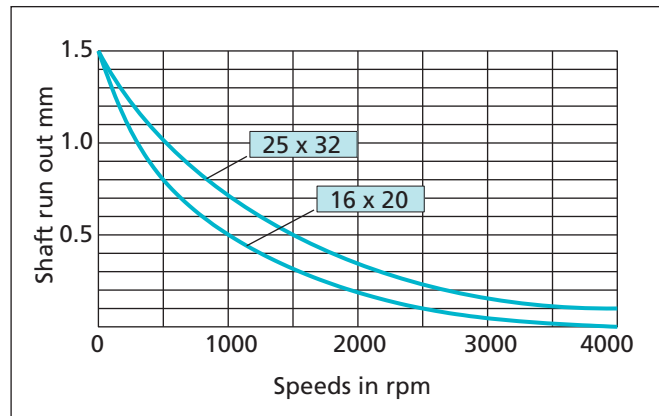

Figure 6 Shaft run out

Installation in the gland

The static seal in the mounting bore is provided by the corresponding force fit allowance at the outer sheath of the seal.

The bore tolerance is specified to DIN ISO 286T2-H8.

Values for the surface roughness in the gland are specified in ISO 6194/1.

General values: Ra = 1.6 - 6.3µm
Rz = 10 - 20µm
Rmax. = 16 - 25µm

For gas sealing, a good score-free and spiral-free surface finish is necessary. If the rotary shaft lip seal is bonded into the housing, ensure that no adhesive comes into contact with the sealing lip or the shaft.

The bore d₂ of the sealing housing indicated in table II as function of shaft diameter. (d₂= d₁+2 x f). See page 4.

The width(b) including the tolerance is also given in table II.



Installation, Type TRJ

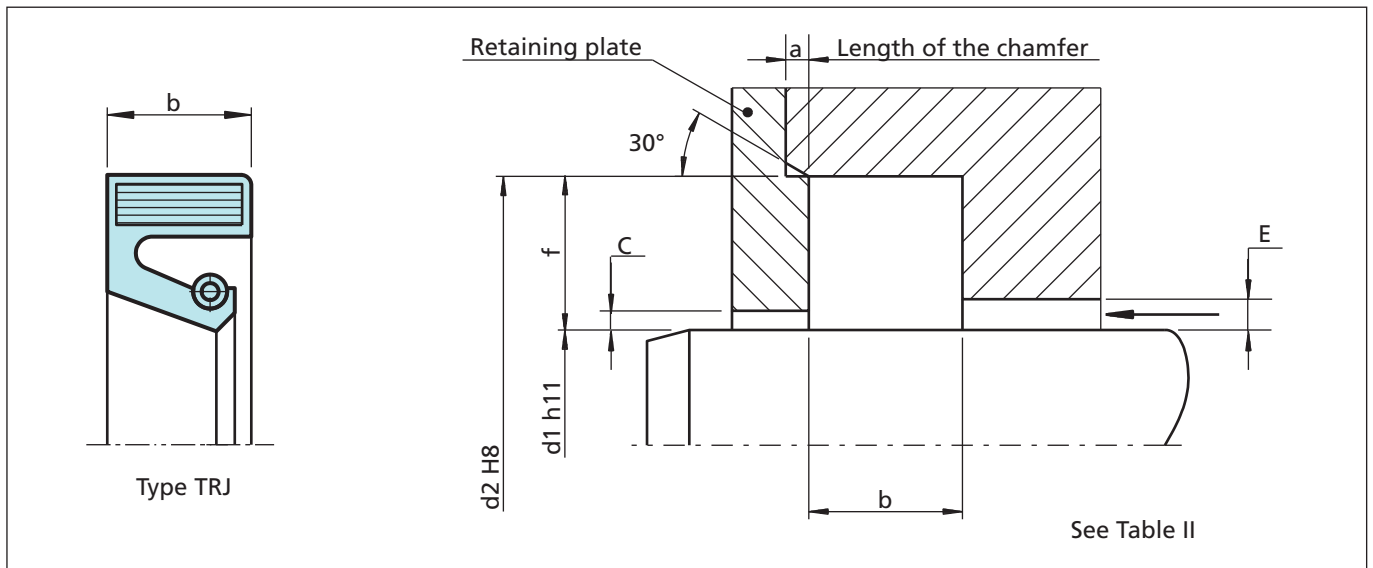

Figure 7 Installation drawing

Installation, Type TRL

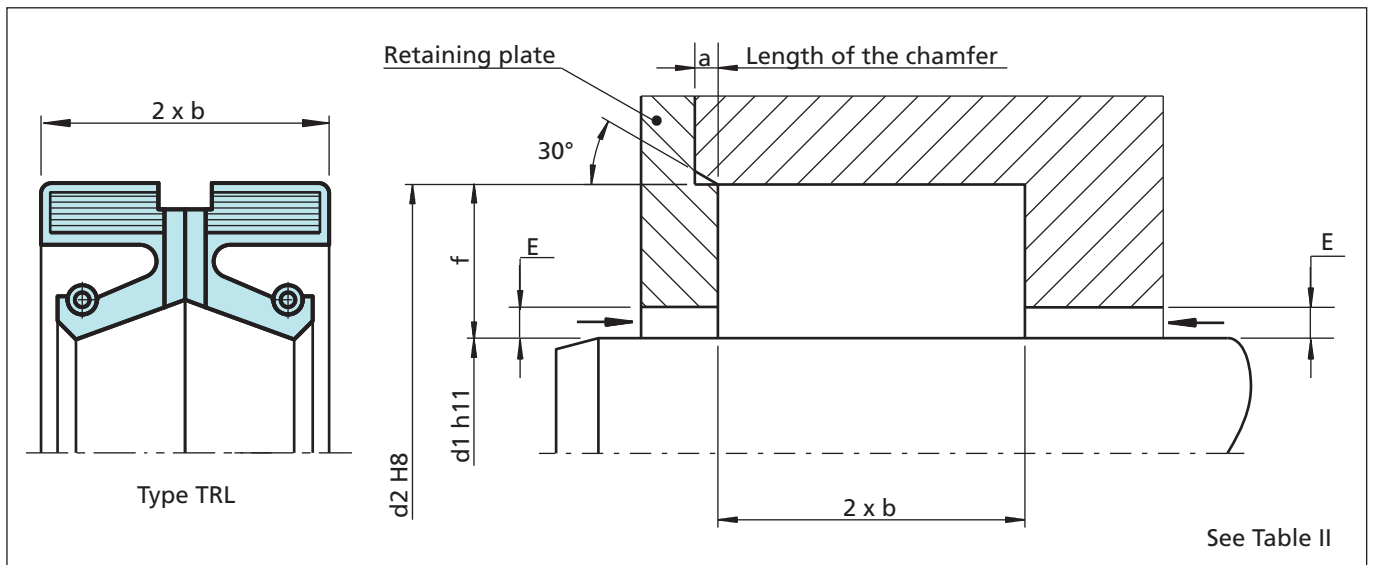

Figure 8 Installation drawing

Table II Dimensions

| d1 | bx f | a | E | C | b |
|-----------|---------|-----|----|---|--------|
| 100 - 250 | 16 x 20 | 2.0 | 9 | 4 | 16±0.1 |
| 250 - 400 | 20 x 22 | 2.2 | 11 | 6 | 20±0.2 |
| 400 - 600 | 22 x 25 | 2.5 | 11 | 7 | 22±0.2 |
| >600 | 25 x 32 | 3.2 | 14 | 8 | 25±0.2 |



Hardness of the shaft

The shaft design is of vital significance for the performance as well as for the life of the seal (see page 3). As a basic principle, the hardness of the shaft should be higher for increasing peripheral speeds. The Standard DIN 3760 specifies that the shaft must be hardened to at least 45 HRC.

As the peripheral speeds increase, the hardness must be increased and at 10 m/s a hardness of 60 HRC is required. The choice of a suitable hardness is dependent not only on the peripheral speed but also on such factors as lubrication and the presence of abrasive particles. Poor lubrication and difficult environmental conditions require a higher hardness of the shaft.

Surface finish and machining methods

DIN 3760 specifies a surface roughness of $R_t=1\mu\text{m}$ to $4\mu\text{m}$. Laboratory tests have however proved that the most suitable roughness is $R_t=2\mu\text{m}$ ($R_a=0.3\mu\text{m}$). Rougher as well as smoother surfaces generate higher friction, resulting in increased temperature and wear. We suggest a surface roughness of $R_t=2-3\mu\text{m}$ ($R_a=0.3-0.8\mu\text{m}$).

Measurements of friction and temperature have also shown that grinding of the shaft is the best method of machining. However spiral grinding marks may cause a pumping effect and leakage and plunge grinding should therefore be applied, during which even ratios between grinding wheel speed and work-piece should be avoided. Polishing of the shaft surface with polishing cloth produces a surface which causes higher friction and heat generated as compared with plunge grinding. In certain cases it maybe impossible to provide the necessary hardness, surface finish and corrosion resistance of the shaft. This problem can be solved by fitting a separate sleeve onto the shaft. If wear should occur, only the sleeve need to be replaced.

Profile forms of surfaces

The functional reliability and service life of a seal depend to a very great extent on the quality and surface finish of the mating surface to be sealed. Scores, scratches, pores, concentric or spiral machining marks are not permitted. Higher demands must be made on the surface finish of dynamic mating surfaces than to static mating surfaces.

The characteristics most frequently used to describe the surface microfinish, R_a , R_z and R_{max} are defined in ISO 4287. These characteristics alone, however, are not sufficient for assessing the suitability in seal engineering. In addition, the material contact area R_{mr} in accordance with ISO 4287 should be considered. The significance of these surface specifications is illustrated in Figure 9. It shows clearly that specification of R_a or R_z alone does not describe the profile form accurately enough and is thus not sufficient for assessing suitability in seal engineering.

The material contact area R_{mr} is essential for assessing surfaces, as this parameter is determined by the specific profile form. This in term is directly depending on the machining process employed.

| Surface profile | R_a | R_z | R_{mr} |
|---|-------|-------|----------|
| closed profile form  | 0.1 | 1.0 | 70% |
| open profile form  | 0.2 | 1.0 | 15% |

Figure 9 Profile forms of surfaces

Dismantling and replacement

The dismantling of seals does not normally present any problems. A screwdriver or similar tool can generally be used. The seal will then be deformed. After repair or maintenance of a machine a new rotary shaft lip seal must always be installed, even if the old ones seem to be still usable. The sealing edge of the new seal must not ride on the old contact area on the shaft. This can be achieved by:

- replacement of shaft sleeves
- fitting the seal into the bore to a different depth
- rework of the shaft and assemble a wear sleeve

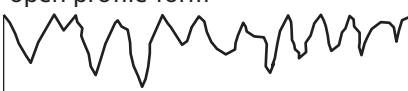

Materials

Sealing element

The demands made on the material must take into account the environmental conditions and the function of the seal.

Some of the requirements associated with environmental considerations are:

- good chemical resistance
- good resistance to heat and low temperature
- good resistance to ozone and weathering

The functional demands include:

- high resistance to wear
- Low friction
- Low compression set
- Good elasticity

In addition, cost considerations render good processability a desirable feature. No material is available today which satisfies all these requirements. The choice of materials is therefore always a compromise between the relative significance of the factors involved.

Type and designations of materials

The materials normally used are:

- Nitrile rubber (NBR)
- Fluorinated rubber (FKM)
- Hydrogenated Nitrile rubber (HNBR)

A further development of the Nitrile rubber has led to the so called hydrogenated Nitrile rubber (HNBR or HSN). The heat and ozone resistance is significantly better. This material can replace Acrylic rubber and in certain cases also Fluorinated rubber. In order to satisfy the wide range of demands made on seals, a special composition has been developed for each type of rubber. Other compositions are also available to meet some extreme requirements.

Table III Material recommendations

| Materials for sealing common media | | Material designation | | |
|---|------------------------------|--|-------------------------|--|
| | | Acrylonitrile Butadiene Rubber NBR | Fluorocarbon Rubber FKM | Hydrogenated Acrylonitrile Butadiene Rubber HNBR |
| | | Material Abbreviation | | |
| | | N | V | H |
| | | Max. permissible constant temperature (°C) | | |
| Mineral fluids | Engine oils | 100 | 170 | 130 |
| | Transmission oils | 80 | 150 | 110 |
| | Hypoid transmission oils | 80 | 150 | 110 |
| | ATF-oils | 100 | 170 | 130 |
| | Hydraulic fluids (DIN 51524) | 90 | 150 | 130 |
| | Greases | 90 | - | 100 |
| Flame retardant hydraulic fluids (VDMA24317) (VDMA 24320) | Oil-water emulsion | 70 | - | 70 |
| | Water-oil emulsion | 70 | - | 70 |
| | Aqueous solutions | 70 | - | 70 |
| | Water-free fluids | - | 150 | - |
| Other media | Fuel oils | 90 | - | 100 |
| | Water (without additives) | 90 | 100 | 100 |
| | Lyes | 90 | 100 | 100 |
| | Air | 100 | 200 | 130 |

All temperature ranges in the table can only be used as a guideline due to the different media configurations. Significant deviations are possible.



Description of rubber materials Nitrile Rubber (NBR)

Advantages:

- Good oil resistance
- Good heat resistance up to +100°C in oil
- High tensile strength
- High elongation at break
- Low swelling in water

Limitations:

- Poor weather and ozone resistance
- Poor resistance against polar fluids (esters, ethers, ketones and aniline)
- Poor resistance against chlorinated hydrocarbons (carbon tetrachloride, trichlorethylene)
- Poor resistance against aromatic hydrocarbons (e.g. benzene, toluene)

Fluids, mineral oils and above all high-alloyed mineral oils (hypoid oils) containing larger quantities of aromatic hydrocarbons are critical as they have a highly swelling effect on NBR compounds. The swelling behavior can be improved by increasing the acrylonitrile content.

However an inferior cold flexibility and resistance to compression set must be accepted. The additives in high-alloyed oils can in certain cases cause an additional interaction between the elastomer and the additive, thus influencing the elasticity.

Hydrogenated nitrile rubber (HNBR)

Advantages:

- Good oil resistance, also in hypoid oils
- Good heat resistance, up to +150°C
- Good mechanical properties
- Good weather and ozone resistance

Limitations:

- Poor resistance against polar fluids (esters, ethers, ketones, acetone and aniline)
- Poor resistance against chlorinated hydrocarbons (carbon tetrachloride, trichlorethylene)
- Poor resistance against aromatic hydrocarbons (e.g. benzene, toluene)

Fluorinated rubber (FKM)

Advantages:

- The resistance against oils and fuels is better than for any other rubber type
- The only rubber material, which is resistant to aromatic and chlorinated hydrocarbons
- Excellent heat resistance, up to +200°C
- Excellent weather and ozone resistance
- Excellent acid resistance (only inorganic acids; not suitable for organic acids e.g. acetic acid)

Limitations:

- Limited cold flexibility, to approx. -20°C
- Limited tensile and tear strength, especially above +100°C
- Limited wear resistance
- Poor resistance to polaric solvents (e.g. acetone)



Temperature resistance

Increasing temperature accelerates the ageing of the rubber, the material becomes hard and brittle, the elongation decreases and the compression set increases. Axial cracks at the sealing edge are a typical indication that the seal has been exposed to excessively high temperature. The ageing of the rubber has appreciable significance on the useful life of the seal. The temperature limits for the principal material are illustrated in figure 10. They should only be regarded as approximate, since the materials are also affected by the medium. It can generally be said that a temperature increase of 10°C (in air) will halve the theoretical useful life of the rubber.

Oil resistance

Innumerable types of oil are available on the market and each of these has a different effect on the rubber.

In addition, a given type of oil from different manufactures may have a different influence. The rubber is generally affected by the additives in the oil. This is the case with hypoid oil which contains sulfur. Since sulfur is used as vulcanizing agent for nitrile rubber, the sulfur additive in the oil acts as a vulcanizing agent at temperatures above + 80°C. As a result of this secondary curing, Nitrile rubber will rapidly become hard and brittle. Hydrogenated Nitrile, Acrylic and Fluorinated rubbers which are not vulcanized with sulfur, can therefore be used for this type of oil, even though the operating temperature may not require these. Oxidized oils represent another example illustrating the difficulty of tabulating the oil resistance of rubber materials. These oils are oxidized during operation and their properties will therefore change substantially. Such oils break down silicone rubber. The values specified in fig. III must thus be regarded as only approximate.

In case of doubt always contact TSS company

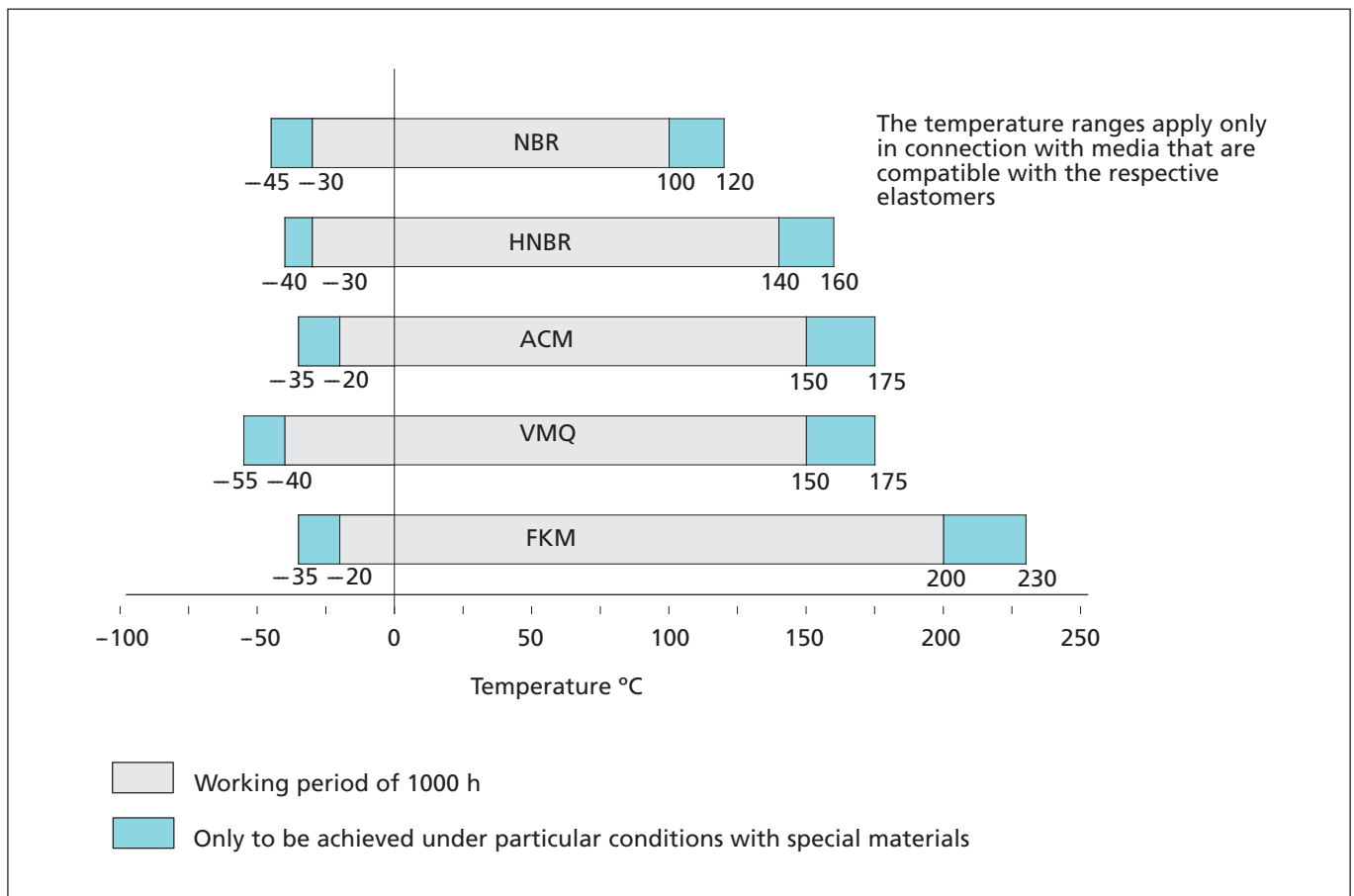

Figure 10 Temperature limits for some common types of rubber



Radial Oil Seal TRJ/TRL

Peripheral speed and number of revolutions

Different designs of the sealing element affect the magnitude of the friction generated and thus the resulting temperature rises. As a result the various designs of the sealing element allow different maximum peripheral speeds. Figure 11 shows the approximate maximum values for the permissible speed for sealing elements (without dust lip), made with materials NBR, ACM, FKM and MVQ, with no differential pressure, and where adequate lubrication or cooling of the sealing edge by the sealed medium exists.

In addition the maximum permissible operating temperature shown in Table III must not be exceeded. The curve shows that higher peripheral speeds are permissible for larger shaft diameters than for smaller. This is due to the fact that the cross-sectional area increases in proportion to the square of the diameter, thus increasing the heat dissipation capacity.

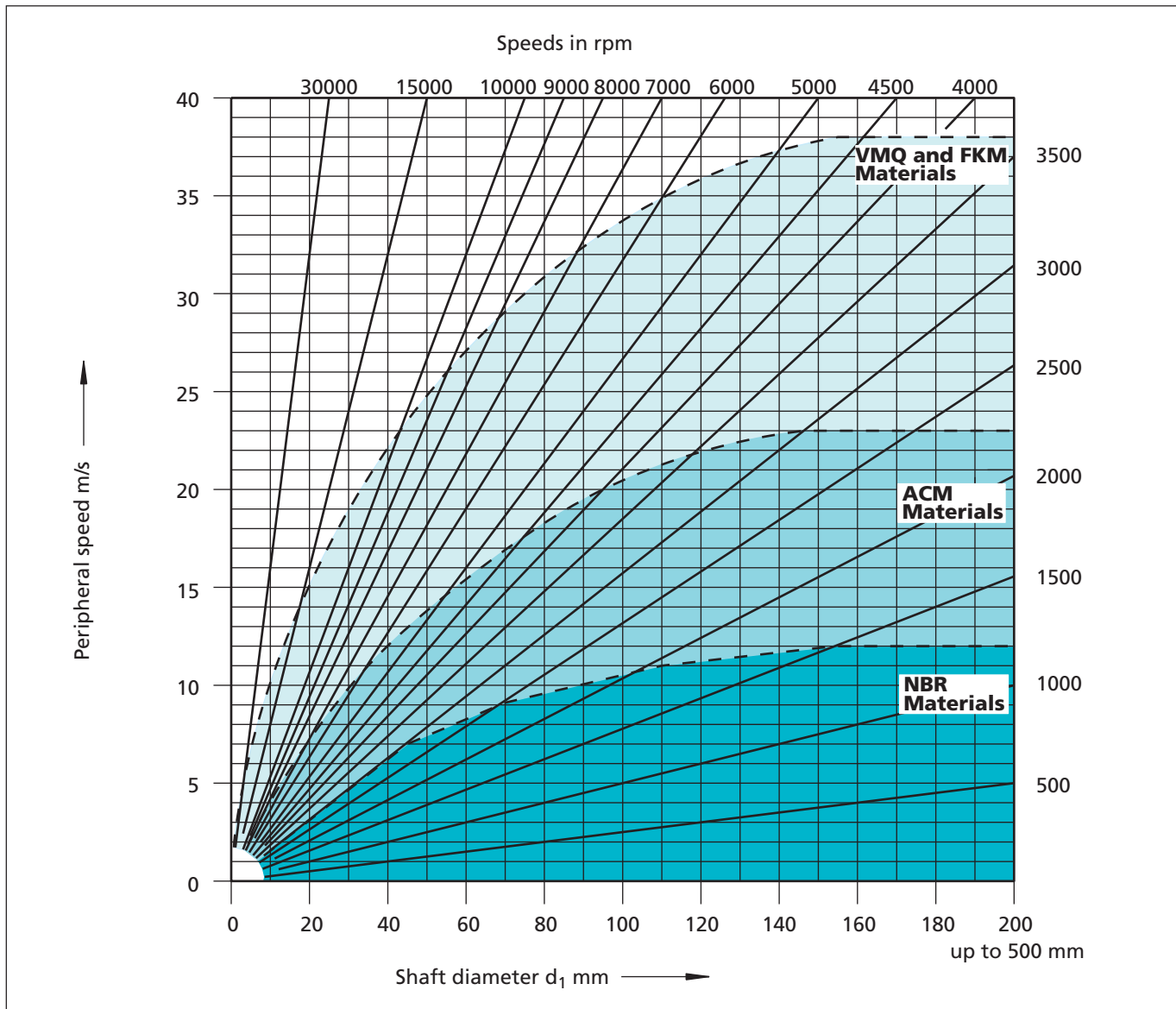

Figure 11 Permissible speeds in pressure- free state to DIN 3761



■ Technical Data, Type TRJ and TRL*

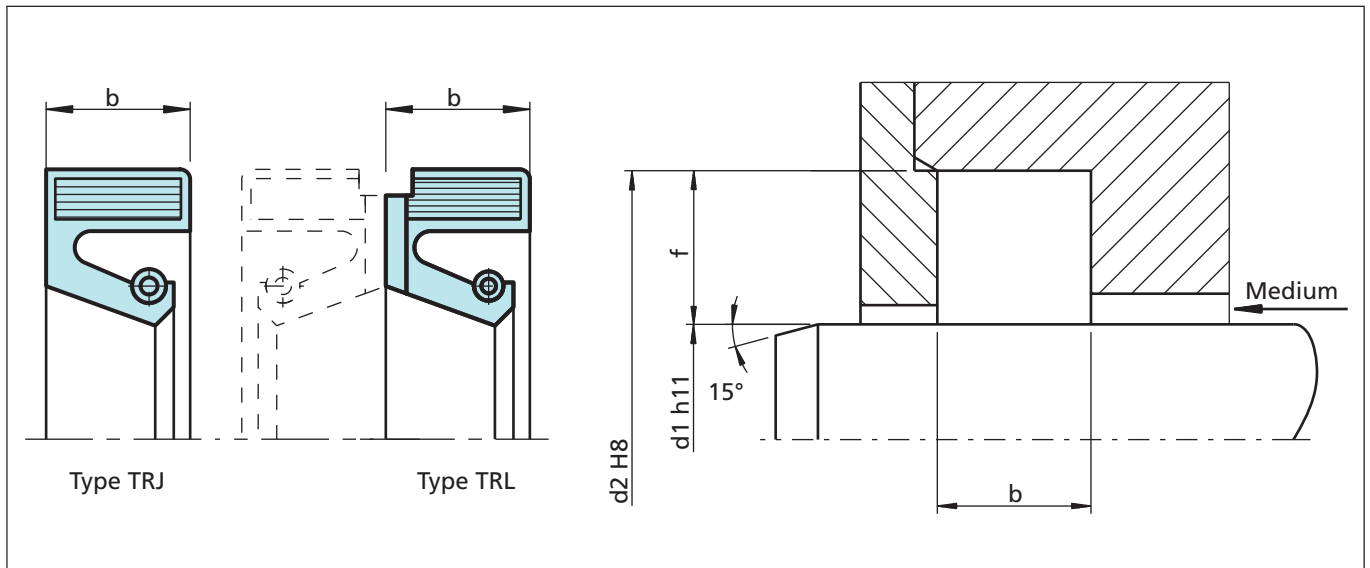

Figure 12 Installation drawing

Table IV Material

| Standard-material* | TSS Material code | Standard-spring** |
|--------------------|-------------------|-------------------|
| NBR (75 Shore A) | 4NC01 | Carbon steel |
| HNBR (75 Shore A) | 4HC01 | Carbon steel |
| FKM (75 Shore A) | 4VC02 | Stainless steel |

**The spring can be supplied in different materials on request.

Table V Technical Data

| Type | Temperature | Speed | Pressure | Dimensions |
|------|-----------------|--------------|----------|------------|
| TRJ | -30°C to +200°C | up to 25 m/s | 0.05 MPa | 100 - 1890 |
| TRL | -30°C to +200°C | up to 25 m/s | 0.05 MPa | 100 - 1890 |

Important Note:

The above data are maximum values and cannot be used at the same time, e.g. the maximum operating speed depends on material type, pressure and temperature.



Radial Oil Seal TRJ/TRL

Table VI Dimensions for Type TRJ/TRL

| Dimensions | | | | Type | |
|----------------|----------------|-------------|-------------|----------|----------|
| d ₁ | d ₂ | b | f | TRJ | TRL |
| 100.0 | 115.0 | 8.9 | 7.5 | X | ○ |
| 100.0 | 115.0 | 9.0 | 7.5 | X | ○ |
| 100.0 | 120.0 | 13.0 | 10.0 | X | ○ |
| 100.0 | 125.0 | 13.0 | 12.5 | X | ○ |
| 100.0 | 125.0 | 15.0 | 12.5 | X | ○ |
| 100.0 | 125.4 | 12.7 | 12.7 | X | X |
| 100.0 | 130.0 | 12.0 | 15.0 | X | ○ |
| 100.0 | 130.0 | 15.0 | 15.0 | X | ○ |
| 100.0 | 132.0 | 12.5 | 16.0 | X | X |
| 100.0 | 140.0 | 16.0 | 20.0 | X | ○ |
| 105.0 | 129.0 | 13.0 | 12.0 | X | ○ |
| 105.0 | 130.0 | 12.0 | 12.5 | X | ○ |
| 105.0 | 130.0 | 13.0 | 12.5 | X | ○ |
| 105.0 | 133.5 | 12.7 | 14.3 | X | ○ |
| 105.0 | 137.0 | 16.0 | 16.0 | X | ○ |
| 105.0 | 140.0 | 12.0 | 17.5 | X | ○ |
| 105.0 | 143.0 | 16.0 | 19.0 | X | ○ |
| 105.0 | 145.0 | 16.0 | 20.0 | X | ○ |
| 110.0 | 126.0 | 9.0 | 8.0 | X | ○ |
| 110.0 | 126.0 | 12.0 | 8.0 | X | ○ |
| 110.0 | 130.0 | 9.0 | 10.0 | X | ○ |
| 110.0 | 130.0 | 12.0 | 10.0 | X | ○ |
| 110.0 | 130.0 | 13.0 | 10.0 | X | ○ |
| 110.0 | 135.0 | 12.0 | 12.5 | X | ○ |
| 110.0 | 140.0 | 12.0 | 15.0 | X | ○ |
| 110.0 | 140.0 | 14.0 | 15.0 | X | ○ |
| 110.0 | 140.0 | 15.0 | 15.0 | X | ○ |
| 110.0 | 140.0 | 16.0 | 15.0 | X | ○ |
| 110.0 | 141.0 | 13.7 | 15.5 | X | ○ |
| 110.0 | 145.0 | 19.0 | 17.5 | X | ○ |
| 110.0 | 150.0 | 16.0 | 20.0 | X | ○ |
| 115.0 | 137.0 | 8.8 | 11.0 | X | ○ |
| 115.0 | 137.0 | 9.0 | 11.0 | | X |
| 115.0 | 140.0 | 12.0 | 12.5 | X | ○ |
| 115.0 | 140.0 | 13.0 | 12.5 | X | X |
| 115.0 | 140.4 | 9.5 | 12.7 | X | ○ |
| 115.0 | 145.0 | 12.0 | 15.0 | X | ○ |
| 115.0 | 145.0 | 15.0 | 15.0 | X | ○ |
| 115.0 | 150.0 | 15.0 | 17.5 | X | ○ |

| Dimensions | | | | Type | |
|----------------|----------------|-------------|-------------|----------|----------|
| d ₁ | d ₂ | b | f | TRJ | TRL |
| 115.0 | 155.0 | 16.0 | 20.0 | X | ○ |
| 118.0 | 140.0 | 14.0 | 11.0 | X | ○ |
| 120.0 | 140.0 | 12.5 | 10.0 | X | ○ |
| 120.0 | 140.0 | 13.0 | 10.0 | X | ○ |
| 120.0 | 140.0 | 14.5 | 10.0 | X | ○ |
| 120.0 | 144.0 | 15.5 | 12.0 | X | ○ |
| 120.0 | 145.0 | 15.5 | 12.5 | X | ○ |
| 120.0 | 150.0 | 13.0 | 15.0 | X | ○ |
| 120.0 | 150.0 | 15.0 | 15.0 | X | ○ |
| 120.0 | 150.0 | 16.0 | 15.0 | X | ○ |
| 120.0 | 152.0 | 16.0 | 16.0 | X | ○ |
| 120.0 | 160.0 | 12.0 | 20.0 | X | ○ |
| 120.0 | 160.0 | 16.0 | 20.0 | X | X |
| 120.0 | 170.0 | 15.0 | 25.0 | X | ○ |
| 125.0 | 140.0 | 10.0 | 7.5 | X | ○ |
| 125.0 | 150.0 | 12.0 | 12.5 | X | ○ |
| 125.0 | 150.0 | 15.0 | 12.5 | X | ○ |
| 125.0 | 153.5 | 12.7 | 14.2 | X | ○ |
| 125.0 | 155.0 | 12.0 | 15.0 | X | ○ |
| 125.0 | 160.0 | 12.0 | 17.5 | X | ○ |
| 125.0 | 160.0 | 13.0 | 17.5 | X | ○ |
| 125.0 | 160.0 | 15.0 | 17.5 | X | ○ |
| 125.0 | 165.0 | 15.0 | 20.0 | X | ○ |
| 125.0 | 165.0 | 16.0 | 20.0 | X | ○ |
| 127.0 | 157.0 | 15.0 | 15.0 | X | ○ |
| 128.0 | 165.0 | 15.0 | 18.5 | X | ○ |
| 130.0 | 150.0 | 10.0 | 10.0 | X | ○ |
| 130.0 | 150.0 | 12.0 | 10.0 | X | ○ |
| 130.0 | 155.0 | 10.0 | 12.5 | X | ○ |
| 130.0 | 155.0 | 15.5 | 12.5 | X | ○ |
| 130.0 | 160.0 | 12.0 | 15.0 | X | ○ |
| 130.0 | 160.0 | 15.0 | 15.0 | X | ○ |
| 130.0 | 160.0 | 16.0 | 15.0 | X | ○ |
| 130.0 | 165.0 | 13.0 | 17.5 | X | ○ |
| 130.0 | 170.0 | 13.0 | 20.0 | X | ○ |
| 130.0 | 170.0 | 16.0 | 20.0 | X | ○ |
| 133.0 | 165.0 | 12.5 | 16.0 | | X |
| 134.0 | 169.0 | 15.0 | 17.5 | X | ○ |
| 135.0 | 157.0 | 8.0 | 11.0 | X | ○ |

"X" Tools available.

"○" As special part available on request.

Dimensions printed in **bold** are preferred sizes. Further sizes on request.

Radial Oil Seal TRJ/TRL



| Dimensions | | | | Type | |
|----------------|----------------|-------------|-------------|----------|----------|
| d ₁ | d ₂ | b | f | TRJ | TRL |
| 135.0 | 160.0 | 12.0 | 12.5 | X | ○ |
| 135.0 | 165.0 | 13.0 | 15.0 | X | ○ |
| 135.0 | 167.0 | 15.0 | 16.0 | X | ○ |
| 135.0 | 170.0 | 12.0 | 17.5 | X | ○ |
| 135.0 | 170.0 | 13.0 | 17.5 | X | ○ |
| 135.0 | 170.0 | 16.5 | 17.5 | X | ○ |
| 135.0 | 175.0 | 16.0 | 20.0 | X | ○ |
| 136.0 | 160.0 | 10.0 | 12.0 | X | ○ |
| 138.0 | 180.0 | 15.0 | 21.0 | X | ○ |
| 139.0 | 155.0 | 10.0 | 8.0 | X | ○ |
| 139.0 | 169.0 | 14.6 | 15.0 | X | ○ |
| 140.0 | 155.0 | 10.0 | 7.5 | X | ○ |
| 140.0 | 160.0 | 13.0 | 10.0 | X | ○ |
| 140.0 | 165.0 | 15.0 | 12.5 | X | ○ |
| 140.0 | 168.0 | 21.0 | 14.0 | X | ○ |
| 140.0 | 170.0 | 15.0 | 15.0 | X | ○ |
| 140.0 | 180.0 | 12.0 | 20.0 | X | ○ |
| 140.0 | 180.0 | 15.0 | 20.0 | X | ○ |
| 140.0 | 180.0 | 16.0 | 20.0 | X | X |
| 140.0 | 190.0 | 15.0 | 25.0 | X | ○ |
| 143.0 | 165.0 | 10.0 | 11.0 | X | ○ |
| 144.0 | 180.0 | 15.0 | 18.0 | X | ○ |
| 145.0 | 170.0 | 13.0 | 12.5 | X | ○ |
| 145.0 | 170.0 | 15.0 | 12.5 | X | ○ |
| 145.0 | 180.0 | 12.0 | 17.5 | X | ○ |
| 145.0 | 180.0 | 14.0 | 17.5 | X | ○ |
| 149.0 | 179.0 | 13.0 | 15.0 | X | ○ |
| 149.0 | 180.0 | 16.0 | 15.5 | X | ○ |
| 150.0 | 172.0 | 12.7 | 11.0 | X | ○ |
| 150.0 | 180.0 | 12.0 | 15.0 | X | X |
| 150.0 | 180.0 | 13.0 | 15.0 | X | ○ |
| 150.0 | 180.0 | 14.0 | 15.0 | X | ○ |
| 150.0 | 180.0 | 15.0 | 15.0 | X | ○ |
| 150.0 | 185.0 | 15.0 | 17.5 | X | ○ |
| 150.0 | 188.0 | 16.0 | 19.0 | X | ○ |
| 150.0 | 190.0 | 16.0 | 20.0 | X | X |
| 150.0 | 190.0 | 20.0 | 20.0 | X | ○ |
| 152.0 | 180.0 | 14.0 | 14.0 | X | ○ |
| 152.0 | 190.0 | 19.0 | 19.0 | X | ○ |

| Dimensions | | | | Type | |
|----------------|----------------|-------------|-------------|----------|----------|
| d ₁ | d ₂ | b | f | TRJ | TRL |
| 154.0 | 180.0 | 12.2 | 13.0 | X | ○ |
| 155.0 | 175.0 | 10.8 | 10.0 | X | ○ |
| 155.0 | 180.0 | 12.5 | 12.5 | X | ○ |
| 155.0 | 180.0 | 15.0 | 12.5 | X | ○ |
| 155.0 | 190.0 | 13.0 | 17.5 | X | ○ |
| 156.0 | 195.0 | 15.0 | 19.5 | | X |
| 159.0 | 200.0 | 16.0 | 20.5 | X | ○ |
| 160.0 | 188.0 | 21.0 | 14.0 | X | ○ |
| 160.0 | 190.0 | 15.0 | 15.0 | X | ○ |
| 160.0 | 190.0 | 16.0 | 15.0 | X | ○ |
| 160.0 | 200.0 | 16.0 | 20.0 | X | X |
| 165.0 | 190.0 | 15.0 | 12.5 | X | ○ |
| 165.0 | 195.0 | 15.0 | 15.0 | X | X |
| 165.0 | 200.0 | 15.0 | 17.5 | X | ○ |
| 165.0 | 203.0 | 19.0 | 19.0 | X | ○ |
| 165.0 | 205.0 | 16.0 | 20.0 | X | ○ |
| 168.0 | 200.0 | 16.0 | 16.0 | X | ○ |
| 169.0 | 200.0 | 12.0 | 15.5 | X | ○ |
| 169.0 | 201.0 | 12.5 | 16.0 | X | ○ |
| 170.0 | 192.0 | 10.7 | 11.0 | X | ○ |
| 170.0 | 195.0 | 14.2 | 12.5 | X | ○ |
| 170.0 | 200.0 | 12.0 | 15.0 | X | X |
| 170.0 | 200.0 | 15.0 | 15.0 | X | ○ |
| 170.0 | 205.0 | 18.0 | 17.5 | X | ○ |
| 170.0 | 210.0 | 16.0 | 20.0 | X | X |
| 170.0 | 220.0 | 15.0 | 25.0 | X | ○ |
| 170.0 | 223.0 | 20.0 | 26.5 | X | ○ |
| 174.0 | 214.0 | 16.0 | 20.0 | X | ○ |
| 175.0 | 200.0 | 15.0 | 12.7 | X | ○ |
| 175.0 | 205.0 | 15.0 | 15.0 | X | X |
| 175.0 | 215.0 | 15.0 | 20.0 | X | ○ |
| 175.0 | 215.0 | 16.0 | 20.0 | X | ○ |
| 180.0 | 200.0 | 15.0 | 10.0 | X | ○ |
| 180.0 | 205.0 | 12.5 | 12.5 | X | ○ |
| 180.0 | 210.0 | 12.0 | 15.0 | X | ○ |
| 180.0 | 210.0 | 15.0 | 15.0 | X | X |
| 180.0 | 212.0 | 16.0 | 16.0 | X | ○ |
| 180.0 | 215.0 | 15.0 | 17.5 | X | ○ |
| 180.0 | 216.0 | 21.8 | 18.0 | X | ○ |

"X" Tools available.

"○" As special part available on request.

Dimensions printed in **bold** are preferred sizes. Further sizes on request.



Radial Oil Seal TRJ/TRL

| Dimensions | | | | Type | |
|----------------|----------------|-------------|-------------|----------|----------|
| d ₁ | d ₂ | b | f | TRJ | TRL |
| 180.0 | 220.0 | 13.0 | 20.0 | X | ○ |
| 180.0 | 220.0 | 16.0 | 20.0 | X | X |
| 180.0 | 230.0 | 16.0 | 25.0 | X | ○ |
| 182.0 | 215.0 | 16.0 | 16.5 | X | ○ |
| 185.0 | 210.0 | 13.0 | 12.5 | X | ○ |
| 185.0 | 215.0 | 15.0 | 15.0 | | X |
| 185.0 | 215.0 | 16.0 | 15.0 | X | ○ |
| 185.0 | 220.0 | 16.0 | 17.5 | X | ○ |
| 185.0 | 225.0 | 16.0 | 20.0 | X | X |
| 185.0 | 230.0 | 16.0 | 22.5 | X | ○ |
| 190.0 | 210.0 | 15.0 | 10.0 | X | ○ |
| 190.0 | 212.0 | 11.7 | 11.0 | X | ○ |
| 190.0 | 215.0 | 16.0 | 12.5 | X | ○ |
| 190.0 | 220.0 | 15.0 | 15.0 | X | X |
| 190.0 | 220.0 | 16.0 | 15.0 | X | ○ |
| 190.0 | 225.0 | 18.0 | 17.5 | X | ○ |
| 190.0 | 230.0 | 15.0 | 20.0 | X | ○ |
| 190.0 | 230.0 | 16.0 | 20.0 | X | X |
| 195.0 | 220.0 | 15.0 | 12.5 | X | ○ |
| 195.0 | 230.0 | 15.0 | 17.5 | X | ○ |
| 195.0 | 230.0 | 16.0 | 17.5 | X | ○ |
| 195.0 | 235.0 | 16.0 | 20.0 | X | ○ |
| 196.0 | 228.0 | 16.0 | 16.0 | X | ○ |
| 196.0 | 235.0 | 19.0 | 19.5 | X | ○ |
| 200.0 | 225.0 | 15.0 | 12.5 | X | ○ |
| 200.0 | 230.0 | 15.0 | 15.0 | X | X |
| 200.0 | 230.0 | 16.0 | 15.0 | X | ○ |
| 200.0 | 235.0 | 18.2 | 17.5 | X | ○ |
| 200.0 | 240.0 | 15.0 | 20.0 | X | ○ |
| 200.0 | 240.0 | 16.0 | 20.0 | X | X |
| 200.0 | 250.0 | 15.0 | 25.0 | X | ○ |
| 200.0 | 250.0 | 18.0 | 25.0 | X | ○ |
| 205.0 | 230.0 | 16.0 | 12.5 | X | ○ |
| 205.0 | 245.0 | 16.0 | 20.0 | X | ○ |
| 205.0 | 245.0 | 20.0 | 20.0 | X | ○ |
| 205.0 | 250.0 | 16.0 | 22.5 | X | ○ |
| 210.0 | 240.0 | 13.0 | 15.0 | X | ○ |
| 210.0 | 245.0 | 15.0 | 17.5 | X | ○ |
| 210.0 | 245.0 | 18.0 | 17.5 | X | ○ |

| Dimensions | | | | Type | |
|----------------|----------------|-------------|-------------|----------|----------|
| d ₁ | d ₂ | b | f | TRJ | TRL |
| 210.0 | 246.0 | 16.0 | 18.0 | X | ○ |
| 210.0 | 250.0 | 15.0 | 20.0 | X | ○ |
| 210.0 | 250.0 | 16.0 | 20.0 | X | X |
| 210.0 | 274.0 | 26.0 | 32.0 | X | ○ |
| 213.0 | 248.0 | 16.0 | 17.5 | X | ○ |
| 215.0 | 240.0 | 12.0 | 12.5 | X | ○ |
| 215.0 | 245.0 | 16.0 | 15.0 | X | X |
| 215.0 | 247.0 | 12.5 | 16.0 | X | ○ |
| 215.0 | 248.0 | 15.0 | 16.5 | X | ○ |
| 215.0 | 251.0 | 12.5 | 18.0 | X | ○ |
| 215.0 | 265.0 | 17.0 | 25.0 | X | ○ |
| 216.0 | 241.5 | 12.7 | 12.7 | X | ○ |
| 216.0 | 254.0 | 16.0 | 19.0 | X | ○ |
| 216.0 | 254.0 | 19.0 | 19.0 | X | ○ |
| 216.9 | 254.0 | 19.0 | 18.5 | X | ○ |
| 218.0 | 245.0 | 12.5 | 13.5 | X | ○ |
| 218.0 | 270.0 | 22.0 | 26.0 | X | ○ |
| 220.0 | 245.0 | 12.5 | 12.5 | | X |
| 220.0 | 250.0 | 12.0 | 15.0 | X | ○ |
| 220.0 | 250.0 | 15.0 | 15.0 | X | X |
| 220.0 | 250.0 | 16.0 | 15.0 | X | ○ |
| 220.0 | 250.0 | 19.0 | 15.0 | X | ○ |
| 220.0 | 254.0 | 16.0 | 17.0 | X | ○ |
| 220.0 | 255.0 | 16.0 | 17.5 | X | ○ |
| 220.0 | 255.0 | 18.0 | 17.5 | X | ○ |
| 220.0 | 258.0 | 25.4 | 19.0 | X | ○ |
| 220.0 | 260.0 | 15.0 | 20.0 | X | ○ |
| 220.0 | 260.0 | 16.0 | 20.0 | X | X |
| 220.0 | 260.0 | 20.0 | 20.0 | X | ○ |
| 220.0 | 260.0 | 22.0 | 20.0 | X | ○ |
| 220.0 | 270.0 | 16.0 | 25.0 | X | ○ |
| 225.0 | 250.0 | 12.5 | 12.5 | X | ○ |
| 225.0 | 260.0 | 16.0 | 17.5 | X | ○ |
| 225.0 | 270.0 | 16.0 | 22.5 | X | ○ |
| 226.0 | 258.0 | 16.0 | 16.0 | X | ○ |
| 228.0 | 268.0 | 16.0 | 20.0 | | X |
| 228.0 | 268.0 | 20.0 | 20.0 | X | ○ |
| 230.0 | 255.0 | 10.0 | 12.5 | X | ○ |
| 230.0 | 255.0 | 11.7 | 12.5 | X | ○ |

"X" Tools available.

"○" As special part available on request.

Dimensions printed in **bold** are preferred sizes. Further sizes on request.

Radial Oil Seal TRJ/TRL



| Dimensions | | | | Type | |
|----------------|----------------|-------------|-------------|----------|----------|
| d ₁ | d ₂ | b | f | TRJ | TRL |
| 230.0 | 255.0 | 15.0 | 12.5 | X | ○ |
| 230.0 | 260.0 | 12.5 | 15.0 | X | ○ |
| 230.0 | 260.0 | 15.0 | 15.0 | X | ○ |
| 230.0 | 260.0 | 16.0 | 15.0 | X | ○ |
| 230.0 | 265.0 | 18.0 | 17.5 | X | ○ |
| 230.0 | 270.0 | 16.0 | 20.0 | X | X |
| 230.0 | 280.0 | 15.0 | 25.0 | X | ○ |
| 230.0 | 280.0 | 23.0 | 25.0 | | X |
| 230.0 | 285.0 | 23.0 | 27.5 | X | ○ |
| 234.9 | 273.0 | 19.0 | 19.1 | X | ○ |
| 235.0 | 270.0 | 16.0 | 17.5 | X | ○ |
| 235.0 | 270.0 | 18.0 | 17.5 | X | ○ |
| 235.0 | 275.0 | 20.0 | 17.5 | X | ○ |
| 236.0 | 276.0 | 16.0 | 20.0 | | X |
| 240.0 | 270.0 | 15.0 | 15.0 | X | ○ |
| 240.0 | 270.0 | 17.0 | 15.0 | X | ○ |
| 240.0 | 275.0 | 18.0 | 20.0 | X | ○ |
| 240.0 | 276.0 | 18.0 | 18.0 | X | ○ |
| 240.0 | 278.0 | 17.0 | 19.0 | X | ○ |
| 240.0 | 280.0 | 16.0 | 20.0 | X | X |
| 240.0 | 280.0 | 17.5 | 20.0 | X | ○ |
| 245.0 | 270.0 | 13.0 | 12.5 | X | ○ |
| 245.0 | 270.0 | 16.0 | 12.5 | X | X |
| 250.0 | 280.0 | 15.0 | 15.0 | X | ○ |
| 250.0 | 280.0 | 16.0 | 15.0 | X | X |
| 250.0 | 285.0 | 18.0 | 17.5 | X | ○ |
| 250.0 | 285.0 | 20.0 | 17.5 | X | ○ |
| 250.0 | 288.0 | 19.0 | 19.0 | X | ○ |
| 250.0 | 290.0 | 16.0 | 20.0 | X | X |
| 250.0 | 300.0 | 20.0 | 25.0 | X | ○ |
| 250.0 | 303.0 | 20.0 | 26.5 | X | ○ |
| 250.0 | 310.0 | 25.0 | 30.0 | X | ○ |
| 253.0 | 285.0 | 11.0 | 16.0 | X | ○ |
| 254.0 | 279.0 | 9.3 | 12.5 | X | ○ |
| 254.0 | 292.0 | 15.9 | 19.0 | X | ○ |
| 255.0 | 285.0 | 11.0 | 15.0 | X | X |
| 255.0 | 285.0 | 15.0 | 15.0 | X | ○ |
| 255.0 | 295.0 | 16.0 | 20.0 | X | X |
| 255.0 | 310.0 | 18.0 | 27.5 | X | ○ |

| Dimensions | | | | Type | |
|----------------|----------------|-------------|-------------|----------|----------|
| d ₁ | d ₂ | b | f | TRJ | TRL |
| 258.0 | 290.0 | 16.0 | 16.0 | X | X |
| 260.0 | 285.0 | 18.0 | 12.5 | X | ○ |
| 260.0 | 290.0 | 16.0 | 15.0 | X | X |
| 260.0 | 290.0 | 19.0 | 15.0 | X | ○ |
| 260.0 | 292.0 | 12.5 | 16.0 | X | ○ |
| 260.0 | 298.0 | 17.0 | 19.0 | X | ○ |
| 260.0 | 300.0 | 18.0 | 20.0 | X | ○ |
| 260.0 | 300.0 | 20.0 | 20.0 | X | ○ |
| 260.0 | 304.0 | 20.0 | 22.0 | X | X |
| 260.0 | 305.0 | 16.0 | 22.5 | X | ○ |
| 260.0 | 305.0 | 22.0 | 22.5 | X | ○ |
| 260.0 | 310.0 | 16.0 | 25.0 | X | ○ |
| 260.0 | 310.0 | 18.0 | 25.0 | X | ○ |
| 264.0 | 309.0 | 21.5 | 22.5 | X | ○ |
| 265.0 | 300.0 | 16.0 | 17.5 | X | X |
| 265.0 | 310.0 | 16.0 | 22.5 | X | ○ |
| 265.0 | 310.0 | 22.0 | 22.5 | X | ○ |
| 270.0 | 300.0 | 15.0 | 15.0 | X | X |
| 270.0 | 310.0 | 16.0 | 20.0 | X | ○ |
| 270.0 | 310.0 | 20.0 | 20.0 | X | ○ |
| 270.0 | 314.0 | 20.0 | 22.0 | X | X |
| 272.0 | 304.0 | 16.0 | 16.0 | X | ○ |
| 272.0 | 304.0 | 16.5 | 16.0 | X | ○ |
| 273.0 | 317.0 | 19.0 | 22.0 | X | ○ |
| 275.0 | 310.0 | 15.0 | 17.5 | X | ○ |
| 277.0 | 317.0 | 19.0 | 20.0 | X | ○ |
| 280.0 | 310.0 | 15.0 | 15.0 | X | ○ |
| 280.0 | 310.0 | 16.0 | 15.0 | X | ○ |
| 280.0 | 318.0 | 15.0 | 19.0 | X | ○ |
| 280.0 | 320.0 | 16.0 | 20.0 | X | X |
| 280.0 | 320.0 | 18.0 | 20.0 | X | ○ |
| 280.0 | 320.0 | 20.0 | 20.0 | X | ○ |
| 280.0 | 324.0 | 20.0 | 22.0 | X | ○ |
| 280.0 | 325.0 | 24.0 | 22.5 | X | ○ |
| 285.0 | 310.0 | 16.0 | 12.5 | X | ○ |
| 285.0 | 325.0 | 16.0 | 20.0 | | X |
| 285.0 | 325.0 | 18.0 | 20.0 | X | ○ |
| 286.0 | 330.0 | 16.0 | 22.0 | X | ○ |
| 290.0 | 320.0 | 15.0 | 15.0 | X | ○ |

"X" Tools available.

"○" As special part available on request.

Dimensions printed in **bold** are preferred sizes. Further sizes on request.



Radial Oil Seal TRJ/TRL

| Dimensions | | | | Type | |
|----------------|----------------|-------------|-------------|----------|----------|
| d ₁ | d ₂ | b | f | TRJ | TRL |
| 290.0 | 322.0 | 12.5 | 16.0 | X | ○ |
| 290.0 | 330.0 | 16.0 | 20.0 | X | ○ |
| 290.0 | 330.0 | 18.0 | 20.0 | X | ○ |
| 290.0 | 330.0 | 20.0 | 20.0 | X | ○ |
| 290.0 | 334.0 | 20.0 | 22.0 | X | X |
| 290.0 | 335.0 | 20.0 | 22.5 | X | ○ |
| 290.0 | 350.0 | 25.0 | 30.0 | X | ○ |
| 295.0 | 325.0 | 15.0 | 15.0 | X | ○ |
| 295.0 | 335.0 | 15.0 | 20.0 | | X |
| 295.0 | 335.0 | 16.0 | 20.0 | X | ○ |
| 295.0 | 339.0 | 20.0 | 22.0 | X | ○ |
| 300.0 | 330.0 | 14.0 | 15.0 | | X |
| 300.0 | 332.0 | 15.0 | 16.0 | X | ○ |
| 300.0 | 332.0 | 16.0 | 16.0 | X | ○ |
| 300.0 | 335.0 | 16.0 | 17.5 | X | ○ |
| 300.0 | 335.0 | 18.0 | 17.5 | X | X |
| 300.0 | 340.0 | 16.0 | 20.0 | X | X |
| 300.0 | 340.0 | 18.0 | 20.0 | X | X |
| 300.0 | 340.0 | 20.0 | 20.0 | X | ○ |
| 300.0 | 340.0 | 25.0 | 20.0 | X | ○ |
| 300.0 | 344.0 | 20.0 | 22.0 | X | X |
| 300.0 | 344.0 | 22.0 | 22.0 | X | ○ |
| 300.0 | 350.0 | 22.0 | 25.0 | X | ○ |
| 300.0 | 350.0 | 25.0 | 25.0 | X | ○ |
| 300.0 | 360.0 | 25.0 | 30.0 | X | ○ |
| 300.0 | 364.0 | 25.0 | 32.0 | X | ○ |
| 300.0 | 370.0 | 18.0 | 35.0 | X | ○ |
| 305.0 | 340.0 | 15.0 | 17.5 | X | ○ |
| 305.0 | 349.0 | 20.0 | 22.0 | X | ○ |
| 305.0 | 355.0 | 15.0 | 25.0 | X | ○ |
| 305.0 | 362.0 | 19.0 | 28.5 | X | ○ |
| 310.0 | 350.0 | 17.5 | 20.0 | X | ○ |
| 310.0 | 350.0 | 18.0 | 20.0 | X | X |
| 310.0 | 354.0 | 20.0 | 22.0 | X | ○ |
| 310.0 | 355.0 | 24.0 | 22.5 | X | ○ |
| 310.0 | 370.0 | 28.0 | 30.0 | X | ○ |
| 314.0 | 355.0 | 20.0 | 20.5 | X | ○ |
| 315.0 | 347.0 | 13.0 | 16.0 | X | ○ |
| 315.0 | 355.0 | 18.0 | 20.0 | X | ○ |

| Dimensions | | | | Type | |
|----------------|----------------|-------------|-------------|----------|----------|
| d ₁ | d ₂ | b | f | TRJ | TRL |
| 315.0 | 359.0 | 20.0 | 22.0 | X | ○ |
| 315.0 | 360.0 | 20.0 | 22.5 | | X |
| 315.0 | 365.0 | 20.0 | 25.0 | X | ○ |
| 315.0 | 380.0 | 29.0 | 32.5 | X | ○ |
| 317.0 | 361.0 | 20.0 | 22.0 | X | X |
| 320.0 | 350.0 | 15.0 | 15.0 | X | ○ |
| 320.0 | 355.0 | 16.0 | 17.5 | X | X |
| 320.0 | 360.0 | 18.0 | 20.0 | X | X |
| 320.0 | 360.0 | 20.0 | 20.0 | X | X |
| 320.0 | 364.0 | 20.0 | 22.0 | X | X |
| 323.0 | 363.0 | 16.0 | 20.0 | X | ○ |
| 325.0 | 365.0 | 16.0 | 20.0 | X | X |
| 325.0 | 365.0 | 20.0 | 20.0 | X | ○ |
| 325.0 | 365.0 | 22.0 | 20.0 | X | ○ |
| 325.0 | 369.0 | 20.0 | 22.0 | X | ○ |
| 325.0 | 375.0 | 22.0 | 25.0 | | X |
| 328.0 | 372.0 | 20.2 | 22.0 | X | ○ |
| 330.0 | 370.0 | 18.0 | 20.0 | X | ○ |
| 330.0 | 370.0 | 20.0 | 20.0 | X | X |
| 330.0 | 374.0 | 19.0 | 22.0 | X | ○ |
| 330.0 | 374.0 | 20.0 | 22.0 | X | X |
| 330.0 | 374.0 | 22.0 | 22.0 | X | ○ |
| 335.0 | 375.0 | 18.0 | 20.0 | X | ○ |
| 335.0 | 379.0 | 20.0 | 22.0 | X | X |
| 335.0 | 400.0 | 35.0 | 32.5 | X | ○ |
| 338.0 | 382.0 | 20.0 | 22.0 | X | ○ |
| 340.0 | 370.0 | 15.0 | 15.0 | X | ○ |
| 340.0 | 370.0 | 18.0 | 15.0 | X | ○ |
| 340.0 | 370.0 | 20.0 | 15.0 | X | ○ |
| 340.0 | 372.0 | 16.0 | 16.0 | X | ○ |
| 340.0 | 373.0 | 16.0 | 16.5 | X | ○ |
| 340.0 | 378.0 | 16.0 | 19.0 | X | ○ |
| 340.0 | 380.0 | 18.0 | 20.0 | X | ○ |
| 340.0 | 380.0 | 20.0 | 20.0 | X | ○ |
| 340.0 | 384.0 | 20.0 | 22.0 | X | ○ |
| 340.0 | 400.0 | 28.0 | 30.0 | X | ○ |
| 345.0 | 389.0 | 20.0 | 22.0 | X | ○ |
| 345.0 | 395.0 | 20.0 | 25.0 | X | ○ |
| 346.0 | 390.0 | 20.0 | 22.0 | X | ○ |

"X" Tools available.

"○" As special part available on request.

Dimensions printed in **bold** are preferred sizes. Further sizes on request.

Radial Oil Seal TRJ/TRL



| Dimensions | | | | Type | |
|----------------|----------------|-------------|-------------|----------|----------|
| d ₁ | d ₂ | b | f | TRJ | TRL |
| 348.0 | 380.0 | 16.0 | 16.0 | X | ○ |
| 350.0 | 380.0 | 16.0 | 15.0 | X | ○ |
| 350.0 | 390.0 | 15.0 | 20.0 | X | ○ |
| 350.0 | 390.0 | 16.0 | 20.0 | X | ○ |
| 350.0 | 390.0 | 18.0 | 20.0 | X | ○ |
| 350.0 | 390.0 | 20.0 | 20.0 | X | X |
| 350.0 | 394.0 | 20.0 | 22.0 | X | X |
| 350.0 | 394.0 | 22.0 | 22.0 | X | ○ |
| 350.0 | 405.0 | 20.0 | 27.5 | X | ○ |
| 355.0 | 379.0 | 20.0 | 12.0 | X | ○ |
| 355.0 | 385.0 | 16.0 | 15.0 | | X |
| 355.0 | 394.0 | 20.0 | 19.5 | X | ○ |
| 355.0 | 410.0 | 25.0 | 27.5 | | X |
| 360.0 | 390.0 | 18.0 | 15.0 | X | ○ |
| 360.0 | 400.0 | 16.0 | 20.0 | X | ○ |
| 360.0 | 400.0 | 18.0 | 20.0 | X | ○ |
| 360.0 | 400.0 | 20.0 | 20.0 | X | ○ |
| 360.0 | 404.0 | 20.0 | 22.0 | X | X |
| 360.0 | 410.0 | 22.0 | 25.0 | X | ○ |
| 362.0 | 400.0 | 20.0 | 19.0 | X | ○ |
| 362.0 | 406.0 | 19.5 | 22.0 | X | ○ |
| 362.0 | 406.0 | 20.0 | 22.0 | X | ○ |
| 362.0 | 406.0 | 22.0 | 22.0 | X | ○ |
| 363.0 | 418.0 | 20.0 | 27.5 | X | ○ |
| 365.0 | 405.0 | 18.0 | 20.0 | X | ○ |
| 365.0 | 409.0 | 20.0 | 22.0 | X | X |
| 370.0 | 410.0 | 15.0 | 20.0 | X | ○ |
| 370.0 | 410.0 | 18.0 | 20.0 | | X |
| 370.0 | 410.0 | 20.0 | 20.0 | X | ○ |
| 370.0 | 414.0 | 19.0 | 22.0 | X | X |
| 370.0 | 414.0 | 20.0 | 22.0 | X | X |
| 370.0 | 414.0 | 25.0 | 22.0 | X | ○ |
| 375.0 | 419.0 | 20.0 | 22.0 | X | ○ |
| 375.0 | 419.0 | 22.2 | 22.0 | X | ○ |
| 375.0 | 420.0 | 16.0 | 22.5 | X | ○ |
| 378.0 | 428.0 | 18.5 | 25.0 | X | ○ |
| 380.0 | 410.0 | 12.5 | 15.0 | X | ○ |
| 380.0 | 420.0 | 15.0 | 20.0 | X | ○ |
| 380.0 | 420.0 | 15.0 | 20.0 | | X |

| Dimensions | | | | Type | |
|----------------|----------------|-------------|-------------|----------|----------|
| d ₁ | d ₂ | b | f | TRJ | TRL |
| 380.0 | 420.0 | 18.0 | 20.0 | X | X |
| 380.0 | 420.0 | 20.0 | 20.0 | X | ○ |
| 380.0 | 420.0 | 20.0 | 20.0 | X | ○ |
| 380.0 | 420.0 | 22.0 | 20.0 | X | ○ |
| 380.0 | 424.0 | 20.0 | 22.0 | X | X |
| 380.0 | 435.0 | 25.0 | 27.5 | X | ○ |
| 380.0 | 438.0 | 23.0 | 29.0 | X | ○ |
| 380.0 | 440.0 | 25.0 | 30.0 | X | ○ |
| 381.0 | 432.0 | 25.0 | 25.5 | X | ○ |
| 384.0 | 414.0 | 15.0 | 15.0 | X | ○ |
| 384.0 | 428.0 | 20.0 | 22.0 | | X |
| 385.0 | 430.0 | 25.0 | 22.5 | X | ○ |
| 385.0 | 438.0 | 32.0 | 26.5 | X | ○ |
| 387.0 | 431.0 | 22.5 | 22.0 | X | X |
| 390.0 | 420.0 | 14.0 | 15.0 | X | ○ |
| 390.0 | 420.0 | 16.0 | 15.0 | X | ○ |
| 390.0 | 430.0 | 18.0 | 20.0 | X | ○ |
| 390.0 | 430.0 | 20.0 | 20.0 | X | ○ |
| 390.0 | 434.0 | 19.2 | 22.0 | X | ○ |
| 390.0 | 434.0 | 20.0 | 22.0 | X | X |
| 390.0 | 440.0 | 22.0 | 25.0 | | X |
| 390.0 | 464.0 | 20.0 | 37.0 | | X |
| 395.0 | 430.0 | 18.0 | 17.5 | X | X |
| 395.0 | 431.0 | 18.0 | 18.0 | X | ○ |
| 395.0 | 439.0 | 20.0 | 22.0 | X | X |
| 400.0 | 438.0 | 17.5 | 19.0 | X | ○ |
| 400.0 | 440.0 | 14.0 | 20.0 | | X |
| 400.0 | 440.0 | 18.0 | 20.0 | X | ○ |
| 400.0 | 440.0 | 20.0 | 20.0 | X | X |
| 400.0 | 444.0 | 19.2 | 22.0 | X | ○ |
| 400.0 | 444.0 | 20.0 | 22.0 | X | X |
| 400.0 | 445.5 | 22.0 | 22.7 | X | ○ |
| 400.0 | 450.0 | 20.0 | 25.0 | X | ○ |
| 400.0 | 450.0 | 22.0 | 25.0 | X | X |
| 405.0 | 455.0 | 22.0 | 25.0 | X | ○ |
| 410.0 | 450.0 | 18.0 | 20.0 | | X |
| 410.0 | 450.0 | 20.0 | 20.0 | X | ○ |
| 413.0 | 455.0 | 20.0 | 21.0 | X | ○ |
| 415.0 | 445.0 | 20.0 | 15.0 | X | ○ |

"X" Tools available.

"○" As special part available on request.

Dimensions printed in **bold** are preferred sizes. Further sizes on request.



Radial Oil Seal TRJ/TRL

| Dimensions | | | | Type | |
|----------------|----------------|-------------|-------------|----------|----------|
| d ₁ | d ₂ | b | f | TRJ | TRL |
| 415.0 | 455.0 | 20.0 | 20.0 | X | ○ |
| 415.0 | 459.0 | 20.0 | 22.0 | X | ○ |
| 417.0 | 467.0 | 25.0 | 25.0 | X | ○ |
| 420.0 | 460.0 | 18.0 | 20.0 | | X |
| 420.0 | 460.0 | 19.0 | 20.0 | X | ○ |
| 420.0 | 460.0 | 20.0 | 20.0 | X | ○ |
| 420.0 | 470.0 | 20.0 | 25.0 | X | ○ |
| 420.0 | 470.0 | 22.0 | 25.0 | X | X |
| 420.0 | 470.0 | 25.0 | 25.0 | X | ○ |
| 430.0 | 470.0 | 20.0 | 20.0 | X | ○ |
| 430.0 | 474.0 | 20.0 | 22.0 | X | ○ |
| 430.0 | 480.0 | 20.0 | 25.0 | X | ○ |
| 430.0 | 480.0 | 22.0 | 25.0 | X | X |
| 430.0 | 480.0 | 25.0 | 25.0 | X | ○ |
| 430.0 | 490.0 | 25.0 | 30.0 | X | ○ |
| 435.0 | 485.0 | 22.0 | 25.0 | X | ○ |
| 435.0 | 485.0 | 30.0 | 25.0 | | X |
| 437.0 | 487.0 | 19.8 | 25.0 | X | ○ |
| 437.0 | 487.0 | 21.5 | 25.0 | X | ○ |
| 440.0 | 469.0 | 12.5 | 14.5 | X | ○ |
| 440.0 | 480.0 | 20.0 | 20.0 | X | ○ |
| 440.0 | 490.0 | 20.0 | 25.0 | X | ○ |
| 440.0 | 490.0 | 20.5 | 25.0 | X | ○ |
| 440.0 | 490.0 | 22.0 | 25.0 | X | X |
| 440.0 | 490.0 | 25.0 | 25.0 | X | ○ |
| 440.0 | 490.0 | 28.0 | 25.0 | | X |
| 445.0 | 495.0 | 22.0 | 25.0 | X | ○ |
| 446.0 | 486.0 | 16.0 | 20.0 | X | X |
| 447.0 | 497.0 | 22.0 | 25.0 | X | ○ |
| 450.0 | 490.0 | 18.0 | 20.0 | | X |
| 450.0 | 494.0 | 20.0 | 22.0 | X | ○ |
| 450.0 | 500.0 | 20.0 | 25.0 | X | ○ |
| 450.0 | 500.0 | 20.0 | 25.0 | | X |
| 450.0 | 500.0 | 22.0 | 25.0 | X | X |
| 450.0 | 500.0 | 25.0 | 25.0 | X | ○ |
| 454.0 | 500.0 | 18.0 | 23.0 | X | ○ |
| 455.0 | 505.0 | 22.0 | 25.0 | | X |
| 458.0 | 494.0 | 12.0 | 18.0 | X | ○ |
| 460.0 | 500.0 | 18.0 | 20.0 | X | ○ |

| Dimensions | | | | Type | |
|----------------|----------------|-------------|-------------|----------|----------|
| d ₁ | d ₂ | b | f | TRJ | TRL |
| 460.0 | 500.0 | 20.0 | 20.0 | X | ○ |
| 460.0 | 510.0 | 22.0 | 25.0 | X | X |
| 460.0 | 510.0 | 25.0 | 25.0 | X | ○ |
| 460.0 | 510.8 | 20.6 | 25.4 | X | ○ |
| 460.0 | 510.8 | 25.4 | 25.4 | X | ○ |
| 460.0 | 520.0 | 30.0 | 30.0 | X | ○ |
| 467.0 | 510.0 | 20.0 | 21.5 | X | ○ |
| 467.0 | 510.0 | 25.0 | 21.5 | | X |
| 470.0 | 520.0 | 22.0 | 25.0 | X | X |
| 470.0 | 520.0 | 25.0 | 25.0 | X | ○ |
| 474.0 | 514.0 | 20.0 | 20.0 | X | ○ |
| 475.0 | 530.0 | 18.0 | 27.5 | X | X |
| 475.0 | 530.0 | 20.0 | 27.5 | X | ○ |
| 477.0 | 527.0 | 22.0 | 25.0 | | X |
| 480.0 | 520.0 | 16.0 | 20.0 | X | ○ |
| 480.0 | 520.0 | 20.0 | 20.0 | X | ○ |
| 480.0 | 530.0 | 22.0 | 25.0 | X | X |
| 480.0 | 530.0 | 25.0 | 25.0 | X | ○ |
| 482.0 | 530.0 | 20.0 | 24.0 | X | ○ |
| 485.0 | 535.0 | 22.0 | 25.0 | X | ○ |
| 490.0 | 540.0 | 22.0 | 25.0 | | X |
| 495.0 | 545.0 | 25.0 | 25.0 | | X |
| 497.0 | 538.0 | 20.0 | 20.5 | X | ○ |
| 500.0 | 540.0 | 20.0 | 20.0 | X | ○ |
| 500.0 | 544.0 | 20.0 | 22.0 | X | ○ |
| 500.0 | 550.0 | 20.0 | 25.0 | X | X |
| 500.0 | 550.0 | 22.0 | 25.0 | X | X |
| 503.0 | 552.0 | 20.0 | 24.5 | X | ○ |
| 508.0 | 555.0 | 22.0 | 23.5 | X | ○ |
| 508.0 | 558.0 | 22.0 | 25.0 | X | ○ |
| 508.0 | 558.0 | 25.0 | 25.0 | X | ○ |
| 510.0 | 550.0 | 20.0 | 20.0 | X | ○ |
| 510.0 | 554.0 | 20.0 | 22.0 | X | ○ |
| 510.0 | 560.0 | 20.0 | 25.0 | X | ○ |
| 510.0 | 560.0 | 22.0 | 25.0 | X | ○ |
| 520.0 | 564.0 | 20.0 | 22.0 | X | ○ |
| 520.0 | 570.0 | 19.0 | 25.0 | X | ○ |
| 520.0 | 570.0 | 22.0 | 25.0 | X | ○ |
| 520.0 | 570.0 | 25.0 | 25.0 | X | ○ |

"X" Tools available.

"○" As special part available on request.

Dimensions printed in **bold** are preferred sizes. Further sizes on request.

Radial Oil Seal TRJ/TRL



| Dimensions | | | | Type | |
|----------------|----------------|-------------|-------------|----------|----------|
| d ₁ | d ₂ | b | f | TRJ | TRL |
| 520.0 | 570.8 | 20.6 | 25.4 | X | ○ |
| 520.0 | 572.0 | 25.0 | 26.0 | X | ○ |
| 525.0 | 575.0 | 22.0 | 25.0 | X | X |
| 527.0 | 587.0 | 30.0 | 30.0 | X | ○ |
| 527.0 | 587.0 | 38.0 | 30.0 | | X |
| 528.0 | 578.0 | 22.0 | 25.0 | | X |
| 530.0 | 565.0 | 20.0 | 17.5 | X | ○ |
| 530.0 | 566.0 | 18.0 | 18.0 | X | ○ |
| 530.0 | 570.0 | 22.0 | 20.0 | X | ○ |
| 530.0 | 580.0 | 20.0 | 25.0 | X | ○ |
| 530.0 | 580.0 | 22.0 | 25.0 | X | ○ |
| 530.0 | 580.0 | 25.0 | 25.0 | X | ○ |
| 530.0 | 580.8 | 22.2 | 25.4 | X | ○ |
| 533.0 | 577.0 | 25.0 | 22.0 | X | ○ |
| 540.0 | 584.0 | 20.0 | 22.0 | X | ○ |
| 540.0 | 590.0 | 22.0 | 25.0 | X | X |
| 540.0 | 590.0 | 25.0 | 25.0 | | X |
| 542.0 | 578.0 | 18.0 | 18.0 | X | ○ |
| 545.0 | 595.0 | 22.0 | 25.0 | X | ○ |
| 550.0 | 600.0 | 22.0 | 25.0 | X | X |
| 550.0 | 610.0 | 25.0 | 30.0 | X | ○ |
| 555.0 | 605.0 | 22.0 | 25.0 | | X |
| 556.0 | 600.0 | 22.0 | 22.0 | X | ○ |
| 558.0 | 589.0 | 19.0 | 15.5 | X | ○ |
| 560.0 | 598.0 | 19.0 | 19.0 | X | ○ |
| 560.0 | 610.0 | 20.0 | 25.0 | X | ○ |
| 560.0 | 610.0 | 22.0 | 25.0 | X | ○ |
| 570.0 | 620.0 | 22.0 | 25.0 | X | X |
| 570.0 | 620.0 | 25.0 | 25.0 | X | ○ |
| 575.0 | 611.0 | 16.0 | 18.0 | X | ○ |
| 575.0 | 625.0 | 22.0 | 25.0 | X | ○ |
| 580.0 | 605.4 | 12.7 | 12.7 | X | ○ |
| 580.0 | 615.0 | 20.0 | 17.5 | X | ○ |
| 580.0 | 616.0 | 16.0 | 18.0 | X | X |
| 580.0 | 630.0 | 22.0 | 25.0 | X | ○ |
| 580.0 | 630.0 | 34.0 | 25.0 | X | ○ |
| 586.0 | 646.0 | 22.0 | 30.0 | X | ○ |
| 590.0 | 640.0 | 20.0 | 25.0 | X | ○ |
| 590.0 | 640.0 | 22.0 | 25.0 | X | ○ |

| Dimensions | | | | Type | |
|----------------|----------------|-------------|-------------|----------|----------|
| d ₁ | d ₂ | b | f | TRJ | TRL |
| 596.0 | 646.0 | 22.0 | 25.0 | X | ○ |
| 600.0 | 632.0 | 12.5 | 16.0 | X | ○ |
| 600.0 | 640.0 | 20.0 | 20.0 | X | ○ |
| 600.0 | 650.0 | 22.0 | 25.0 | X | ○ |
| 600.0 | 650.0 | 30.0 | 25.0 | X | ○ |
| 600.0 | 664.0 | 25.0 | 32.0 | | X |
| 603.0 | 640.0 | 16.0 | 18.5 | X | ○ |
| 604.0 | 640.0 | 18.0 | 18.0 | X | ○ |
| 610.0 | 660.0 | 22.0 | 25.0 | X | ○ |
| 614.0 | 659.0 | 20.0 | 22.5 | X | ○ |
| 615.0 | 665.0 | 24.5 | 25.0 | X | ○ |
| 615.0 | 679.0 | 25.0 | 32.0 | X | ○ |
| 620.0 | 670.0 | 22.0 | 25.0 | X | ○ |
| 620.0 | 684.0 | 25.0 | 32.0 | X | X |
| 625.0 | 689.0 | 25.0 | 32.0 | X | ○ |
| 640.0 | 680.0 | 20.0 | 20.0 | | X |
| 650.0 | 689.0 | 19.0 | 19.5 | X | ○ |
| 650.0 | 690.0 | 20.0 | 20.0 | X | ○ |
| 650.0 | 700.0 | 22.0 | 25.0 | | X |
| 650.0 | 714.0 | 25.0 | 32.0 | X | X |
| 650.0 | 720.0 | 28.5 | 35.0 | | X |
| 660.0 | 710.0 | 22.0 | 25.0 | X | ○ |
| 660.0 | 724.0 | 25.0 | 32.0 | X | ○ |
| 660.0 | 724.0 | 28.0 | 32.0 | | X |
| 665.0 | 729.0 | 25.0 | 32.0 | X | X |
| 670.0 | 714.0 | 22.0 | 22.0 | | X |
| 670.0 | 735.0 | 25.0 | 32.5 | X | ○ |
| 680.0 | 730.0 | 20.0 | 25.0 | X | ○ |
| 681.0 | 744.5 | 25.4 | 31.7 | X | ○ |
| 685.0 | 749.0 | 25.0 | 32.0 | X | ○ |
| 686.0 | 740.0 | 25.0 | 27.0 | X | ○ |
| 700.0 | 764.0 | 25.0 | 32.0 | X | X |
| 710.0 | 760.0 | 20.0 | 25.0 | X | ○ |
| 710.0 | 770.0 | 30.0 | 30.0 | X | ○ |
| 710.0 | 774.0 | 25.0 | 32.0 | X | X |
| 715.0 | 779.0 | 25.0 | 32.0 | X | ○ |
| 720.0 | 760.0 | 18.0 | 20.0 | | X |
| 730.0 | 794.0 | 25.0 | 32.0 | X | X |
| 735.0 | 793.0 | 25.0 | 29.0 | | X |

"X" Tools available.

"○" As special part available on request.

Dimensions printed in **bold** are preferred sizes. Further sizes on request.



Radial Oil Seal TRJ/TRL

| Dimensions | | | | Type | |
|----------------|----------------|-------------|-------------|----------|----------|
| d ₁ | d ₂ | b | f | TRJ | TRL |
| 740.0 | 780.0 | 18.0 | 20.0 | | X |
| 740.0 | 790.0 | 20.0 | 25.0 | X | ○ |
| 744.0 | 794.0 | 25.0 | 25.0 | | X |
| 744.0 | 808.0 | 25.0 | 32.0 | X | ○ |
| 750.0 | 780.0 | 18.0 | 15.0 | X | ○ |
| 750.0 | 789.0 | 19.0 | 19.5 | X | ○ |
| 750.0 | 810.0 | 30.0 | 30.0 | X | ○ |
| 750.0 | 814.0 | 25.0 | 32.0 | X | ○ |
| 760.0 | 800.0 | 20.0 | 20.0 | X | ○ |
| 760.0 | 820.0 | 30.0 | 30.0 | X | ○ |
| 762.0 | 803.0 | 25.4 | 20.5 | | X |
| 762.0 | 825.5 | 25.4 | 31.7 | X | ○ |
| 765.0 | 825.0 | 26.0 | 30.0 | X | ○ |
| 770.0 | 845.0 | 27.5 | 37.5 | | X |
| 775.0 | 839.0 | 25.0 | 32.0 | X | ○ |
| 775.0 | 839.0 | 31.0 | 32.0 | | X |
| 777.0 | 841.0 | 25.0 | 32.0 | X | ○ |
| 780.0 | 820.0 | 18.0 | 20.0 | X | X |
| 780.0 | 844.0 | 25.0 | 32.0 | X | ○ |
| 786.0 | 836.0 | 25.0 | 25.0 | X | ○ |
| 790.0 | 850.0 | 30.0 | 30.0 | X | ○ |
| 790.0 | 854.0 | 25.0 | 32.0 | X | ○ |
| 800.0 | 860.0 | 30.0 | 30.0 | X | ○ |
| 800.0 | 864.0 | 25.0 | 32.0 | X | X |
| 800.0 | 870.0 | 30.0 | 35.0 | X | ○ |
| 810.0 | 860.0 | 25.0 | 25.0 | X | ○ |
| 810.0 | 870.0 | 25.0 | 30.0 | X | ○ |
| 810.0 | 874.0 | 25.0 | 32.0 | | X |
| 820.0 | 884.0 | 25.0 | 32.0 | X | ○ |
| 832.0 | 870.0 | 19.0 | 19.0 | X | ○ |
| 840.0 | 904.0 | 25.0 | 32.0 | X | ○ |
| 850.0 | 914.0 | 25.0 | 32.0 | X | X |
| 860.0 | 920.0 | 25.0 | 30.0 | X | ○ |
| 860.0 | 924.0 | 25.0 | 32.0 | | X |
| 870.0 | 934.0 | 25.0 | 32.0 | | X |
| 880.0 | 944.0 | 25.0 | 32.0 | X | ○ |
| 889.0 | 970.0 | 21.0 | 40.5 | | X |
| 890.0 | 954.0 | 25.0 | 32.0 | X | ○ |
| 898.0 | 960.0 | 30.0 | 31.0 | | X |

| Dimensions | | | | Type | |
|----------------|----------------|-------------|-------------|----------|----------|
| d ₁ | d ₂ | b | f | TRJ | TRL |
| 900.0 | 960.0 | 30.0 | 30.0 | X | ○ |
| 910.0 | 966.0 | 25.0 | 28.0 | | X |
| 920.0 | 984.0 | 25.0 | 32.0 | X | ○ |
| 935.0 | 999.0 | 25.0 | 32.0 | X | ○ |
| 940.0 | 995.0 | 25.0 | 27.5 | | X |
| 940.0 | 1000.0 | 30.0 | 30.0 | X | ○ |
| 950.0 | 1000.0 | 25.0 | 25.0 | X | ○ |
| 950.0 | 1010.0 | 30.0 | 30.0 | X | ○ |
| 960.0 | 1024.0 | 25.0 | 32.0 | X | ○ |
| 1000.0 | 1050.0 | 25.0 | 25.0 | | X |
| 1000.0 | 1064.0 | 25.0 | 32.0 | X | ○ |
| 1020.0 | 1084.0 | 25.0 | 32.0 | X | ○ |
| 1055.0 | 1119.0 | 25.0 | 32.0 | | X |
| 1060.0 | 1124.0 | 25.0 | 32.0 | | X |
| 1150.0 | 1214.0 | 25.0 | 32.0 | X | ○ |
| 1220.0 | 1284.0 | 25.0 | 32.0 | | X |
| 1250.0 | 1300.0 | 22.0 | 25.0 | | X |
| 1250.0 | 1314.0 | 25.0 | 32.0 | X | ○ |
| 1320.0 | 1398.0 | 32.0 | 39.0 | X | ○ |
| 1320.0 | 1420.0 | 49.0 | 50.0 | | X |
| 1580.0 | 1644.0 | 25.0 | 32.0 | | X |
| 1790.0 | 1854.0 | 24.7 | 32.0 | | X |
| 1890.0 | 1954.0 | 25.0 | 32.0 | | X |

Ordering example

TSS Code: TRJ

Dimensions: Shaft diameter: 100 mm
Housing diameter: 115 mm
Width: 8.9 mm

Material: NBR
Material-Code: 4NC01

| | | | |
|-----------------|-----|-------------|-------|
| TSS Article No. | TRJ | 100x115x8,9 | 4NC01 |
| TSS Code | | | |
| Dimension | | | |
| Material | | | |

"X" Tools available.

"○" As special part available on request.

Dimensions printed in **bold** are preferred sizes. Further sizes on request.



■ Quality criteria

The cost-effective use of seals and bearings is highly influenced by the quality criteria applied in production. Seals and bearings from Trelleborg Sealing Solutions are continuously monitored according to strict quality standards from material acquisition through to delivery.

Certification of our production plants in accordance with international standards QS 9000 / ISO 9000 meets the specific requirements for design, quality control and management of purchasing, production and marketing functions.

Our quality policy is consistently controlled by strict procedures and guidelines which are implemented within all strategic areas of the company.

All testing of materials and products is performed in accordance with accepted test standards and specifications, e.g. random sample testing in accordance with DIN ISO 2859, part 1. Inspection specifications correspond to standards applicable to individual product groups (e.g. for O-Rings: ISO 3601).

Our sealing materials are produced free of chlorofluorinated hydrocarbons and carcinogenic elements.

The tenth digit of our part number defines the quality characteristics of the part. A hyphen indicates compliance with standard quality criteria outlined in this catalogue. Customer-specific requirements are indicated by a different symbol in this position. Customers who require special quality criteria should contact their local Trelleborg Sealing Solutions sales office for assistance. We have experience in meeting all Customer quality requirements.

■ Storage and shelf life

Seals and bearings are often stored as spare parts for prolonged periods. Most rubbers change in physical properties during storage and ultimately become unserviceable due to e.g. excessive hardening, softening, cracking, crazing or other surface degradation. These changes may be the result of particular factors or combination of factors, such as the action of deformation, oxygen, ozone, light, heat, humidity or oils and solvents.

With a few simple precautions, the shelf life of these products can be considerably lengthened.

Fundamental instructions on storage, cleaning and maintenance of elastomeric seal elements are described in international standards, such as:

DIN 7716 / BS 3F68:1977,

ISO 2230, or

DIN 9088

The standards give several recommendations for the storage and the shelf life of elastomers, depending on the material classes.

The following recommendations are based on the several standards and are intended to provide the most suitable conditions for storage of rubbers. They should be observed to maintain the optimum physical and chemical values of the parts:

Heat

The storage temperature should preferably be between +5 °C and +25 °C. Direct contact with sources of heat such as boilers, radiators and direct sunlight should be avoided. If the storage temperature is below +5 °C, care should be taken to avoid distorting them during handling at that temperature as they may have stiffened. In this case the temperature of the articles should be raised to approximately +20 °C before they are put into service.

Humidity

The relative humidity in the store room should be below 70 %. Very moist or very dry conditions should be avoided. Condensation should not occur.

Light

Elastomeric seals should be protected from light sources, in particular direct sunlight or strong artificial light with an ultraviolet content. The individual storage bags offer the best protection as long as they are UV resistant.

It is advisable to cover any windows of storage rooms with a red or orange coating or screen.



Radial Oil Seal TRJ/TRL

Radiation

Precaution should be taken to protect stored articles from all sources of ionising radiation likely to cause damage to stored articles.

Oxygen and ozone

Where possible, elastomeric materials should be protected from circulating air by wrapping, storage in airtight containers or by other suitable means.

As ozone is particularly deleterious to some elastomeric seals, storage rooms should not contain any equipment that is capable of generating ozone, such as mercury vapour lamps, high voltage electrical equipment, electric motors or other equipment which may give rise to electric sparks or silent electrical discharges. Combustion gases and organic vapour should be excluded from storage rooms as they may give rise to ozone via photochemical processes.

Deformation

Elastomeric materials should, wherever possible, be stored in a relaxed condition free from tension, compression or other deformation. Where articles are packed in a strain-free condition they should be stored in their original packaging.

Contact with liquid and semi-solid materials

Elastomeric seals should not be allowed to come into contact with solvents, oils, greases or any other semi-solid materials at any time during storage, unless so packed by the manufacturer.

Contact with metal and non-metals

Direct contact with certain metals, e.g. manganese, iron and particularly copper and its alloys, e.g. brass and compounds of these materials are known to have deleterious effects on some rubbers. Elastomeric seals should not be stored in contact with such metals.

Because of possible transfer of plasticisers or other ingredients, rubbers must not be stored in contact with PVC. Different rubbers should preferably be separated from each other.

Cleaning

Where necessary, cleaning should be carried out with the aid of soap and water or methylated spirits. Water should not, however, be permitted to come into contact with fabric reinforced components, bonded seals (because of corrosion) or polyurethane rubbers. Disinfectants or other organic solvents as well as sharp-edged objects must not be used. The articles should be dried at room temperature and not placed near a source of heat.

Shelf life and shelf life control

The useful life of a elastomeric seals will depend to a large extent on the type of rubber. When stored under the recommended conditions (above sections) the below given shelf life of several materials shown below should be considered.

| | |
|------------------------|-----------|
| AU, Thermoplastics | 4 years |
| NBR, HNBR, CR | 6 years |
| EPDM | 8 years |
| FKM, VMQ, FVMQ | 10 years |
| FFKM, Isolast® | 18 years |
| Turcon® and other PTFE | unlimited |

Elastomeric seals should be inspected after the given period. After this if the parts have not deteriorated an extension period is possible.

Rubber details and components less than 1.5 mm thick are liable to be more seriously affected by oxidation degradation even when stored in satisfactory conditions as recommended. Therefore they may be inspected and tested more frequently than it is mentioned above.

Rubber details / seals in assembled components

It is recommended that the units should be exercised at least every six months and that the maximum period a rubber detail be allowed to remain assembled within a stored unit, without inspection, be a total of the initial period stated above and the extension period. Naturally this will depend on the design of the unit concerned.



Contact your local marketing company for further information:

| Europe | Telephone | Americas | Telephone |
|---|-----------------------|--|----------------------|
| AUSTRIA - Vienna <small>(ALBANIA, BOSNIA AND HERZEGOVINA, MACEDONIA, SERBIA AND MONTENEGRO, SLOVENIA)</small> | +43 (0) 1 406 47 33 | AMERICAS - REGIONAL | +1 260 749 9631 |
| BELGIUM - Dion-Valmont <small>(LUXEMBOURG)</small> | +32 (0) 10 22 57 50 | BRAZIL - São Paulo | +55 11 3372 4500 |
| BULGARIA - Sofia <small>(ROMANIA)</small> | +359 (0)2 969 95 99 | CANADA - Etobicoke, ON | +1 416 213 9444 |
| CROATIA - Zagreb | +385 (0) 1 24 56 387 | MEXICO - Mexico City | +52 55 57 19 50 05 |
| CZECH REPUBLIC - Rakovnik <small>(SLOVAKIA)</small> | +420 313 529 111 | USA, East - Conshohocken, PA | +1 610 828 3209 |
| DENMARK - Hillerød | +45 48 22 80 80 | USA, Great Lakes - Fort Wayne, IN | +1 260 482 4050 |
| FINLAND - Vantaa <small>(ESTONIA, LATVIA)</small> | +358 (0) 207 12 13 50 | USA, Midwest - Lombard, IL | +1 630 268 9915 |
| FRANCE - Maisons-Laffitte | +33 (0) 1 30 86 56 00 | USA, Mountain - Broomfield, CO | +1 303 469 1357 |
| GERMANY - Stuttgart | +49 (0) 711 7864 0 | USA, Northern California - Fresno, CA | +1 559 449 6070 |
| GREECE | +41 (0) 21 631 41 11 | USA, Northwest - Portland, OR | +1 503 595 6565 |
| HUNGARY - Budaörs | +36 (0) 23 50 21 21 | USA, South - N. Charleston, SC | +1 843 747 7656 |
| ITALY - Livorno | +39 0586 22 6111 | USA, Southwest - Houston, TX | +1 713 461 3495 |
| THE NETHERLANDS - Barendrecht | +31 (0) 10 29 22 111 | USA, West - Torrance, CA | +1 310 371 1025 |
| NORWAY - Oslo | +47 22 64 60 80 | | |
| POLAND - Warsaw <small>(LITHUANIA, UKRAINE, BELARUS)</small> | +48 (0) 22 863 30 11 | Asia Pacific | Telephone |
| RUSSIA - Moscow | +7 495 982 39 21 | ASIA PACIFIC REGIONAL | +65 6 577 1778 |
| SPAIN - Madrid <small>(PORTUGAL)</small> | +34 (0) 91 71057 30 | CHINA - Hong Kong | +852 2366 9165 |
| SWEDEN - Jönköping | +46 (0) 36 34 15 00 | CHINA - Shanghai | +86 (0) 21 6145 1830 |
| SWITZERLAND - Crissier | +41 (0) 21 631 41 11 | INDIA - Bangalore | +91 (0) 80 2245 5157 |
| TURKEY | +41 (0) 21 631 41 11 | JAPAN - Tokyo | +81 (0) 3 5633 8008 |
| UNITED KINGDOM - Solihull <small>(EIRE)</small> | +44 (0) 121 744 1221 | KOREA - Anyang | +82 (0) 31 386 3283 |
| AFRICA REGIONAL | +41 (0) 21 631 41 11 | MALAYSIA - Kuala Lumpur | +60 (0) 3 9059 6388 |
| MIDDLE EAST REGIONAL | +41 (0) 21 631 41 11 | TAIWAN - Taichung | +886 4 2382 8886 |
| | | THAILAND - Bangkok | +66 (0) 2732-2861 |
| | | SINGAPORE | |
| | | and all other countries in Asia | +65 6 577 1778 |

www.tss.trelleborg.com

