

# Quad-Ring®

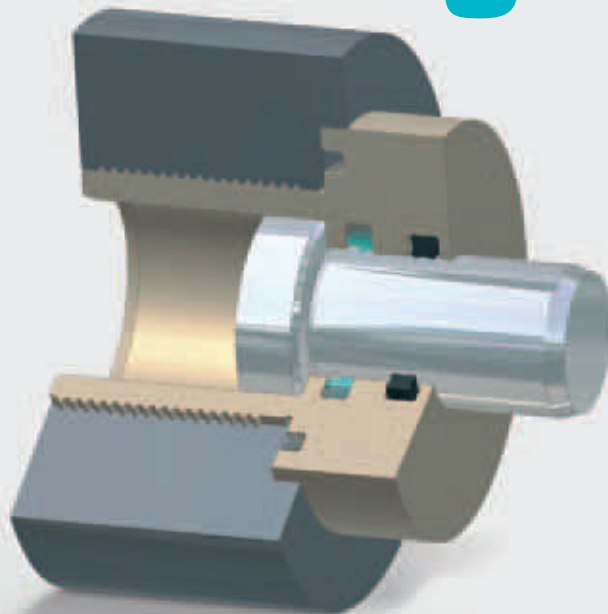

**Your Partner for Sealing Technology**



## Your Partner for Sealing Technology

Trelleborg Sealing Solutions is a major international sealing force, uniquely placed to offer dedicated design and development from our market-leading product and material portfolio: a one-stop-shop providing the best in elastomer, thermoplastic, PTFE and composite technologies for applications in aerospace, industrial and automotive industries.

With 50 years of experience, Trelleborg Sealing Solutions engineers support customers with design, prototyping, production, test and installation using state-of-the-art design tools. An international network of over 70 facilities worldwide includes over 25 manufacturing sites, strategically-positioned research and development centers, including materials and development laboratories and locations specializing in design and applications.

Developing and formulating materials in-house, we utilize the resource of our material database, including over 2,000 proprietary compounds and a range of unique products.

Trelleborg Sealing Solutions fulfills challenging service requirements, supplying standard parts in volume or a single custom-manufactured component, through our integrated logistical support, which effectively delivers over 40,000 sealing products to customers worldwide.

Facilities are certified to ISO 9001:2008 and ISO/TS 16949:2009. Trelleborg Sealing Solutions is backed by the experiences and resources of one of the world's foremost experts in polymer technology: the Trelleborg Group.

ISO 9001:2008

ISO/TS 16949:2009

The information in this brochure is intended to be for general reference purposes only and is not intended to be a specific recommendation for any individual application. The application limits for pressure, temperature, speed and media given are maximum values determined in laboratory conditions. In application, due to the interaction of operating parameters, maximum values may not be achieved. It is vital therefore, that customers satisfy themselves as to the suitability of product and material for each of their individual applications. Any reliance on information is therefore at the user's own risk. In no event will Trelleborg Sealing Solutions be liable for any loss, damage, claim or expense directly or indirectly arising or resulting from the use of any information provided in this brochure. While every effort is made to ensure the accuracy of information contained herewith, Trelleborg Sealing Solutions cannot warrant the accuracy or completeness of information.

**To obtain the best recommendation for a specific application, please contact your local Trelleborg Sealing Solutions marketing company.**

This edition supersedes all previous brochures.

This brochure or any part of it may not be reproduced without permission.

© All trademarks are the property of Trelleborg Group.

The turquoise color is a registered trademark of Trelleborg Group.

© 2011, Trelleborg Group. All rights reserved.

QUAD-RING® is a trademark of Quadion Corporation.



## Contents

Description .....	2
Applications .....	3
Materials .....	4
Characteristics and inspection of elastomers .....	4
Design Instructions .....	6
Installation Instructions .....	10
Installation Recommendations .....	11
Quad-Ring® Seal dimensions in dependence on the American O-Ring standard AS 568 .....	13
Installation Recommendation Quad-Ring® Seal with Back-up Ring for Radial-Dynamic Application (Reciprocating) - "Extentral Sealing" - .....	18
Installation Recommendation Quad-Ring® Seal with Back-up Ring for Radial-Dynamic Application (Reciprocating) - "Internal Sealing" - .....	21
Installation Recommendation Quad-Ring® Seal and Back-up Ring (Uncut) for Rotary Application - "Internal Sealing" - .....	24
General quality criteria .....	26
Guidelines for the storage of polymer products based on ISO 2230 .....	26
Conversion Tables .....	28



# Quad-Ring® Seal

## ■ Description

Original Quad-Ring® Seals are four lipped seals with a specially developed sealing profile.

A wide range of elastomer materials for both standard and special applications allows practically all liquid and gaseous media to be sealed.

Quad-Ring® Seals are vulcanized as a continuous ring. They are characterized by their annular form with a four lipped profile. Their dimensions are specified with the inside diameter  $d_1$  and the cross-section  $W$  (Figure 1).

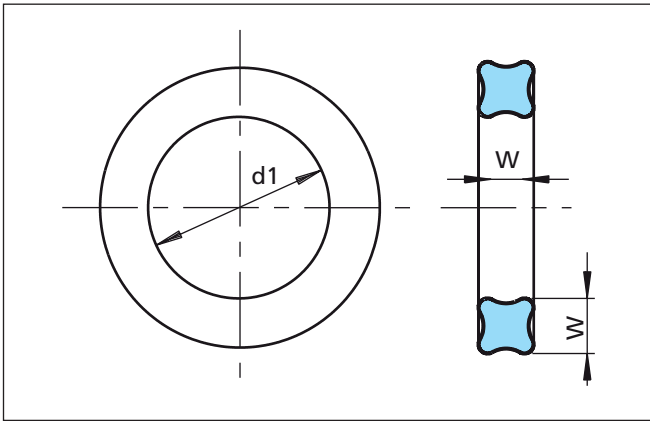

Figure 1 Quad-Ring® Seal dimensioning

Quad-Ring® Seals are supplied in dependence on the American O-Ring Standard AS 568.

## Advantages

In contrast to the O-Ring, Quad-Ring® Seal has the following advantages:

- Avoids twisting in the groove. Due to its special profile, the seal does not tend to roll in the groove during reciprocating movement.
- Low friction.
- Very good sealing efficiency. Due to an improved pressure profile over Quad-Ring® Seal cross-section, a high sealing effect is achieved.
- A lubricant reservoir formed between the sealing lips improves start up.
- Unlike an O-Ring, the mould line flash lies in the trough, between and away from the critical sealing lips.

## Method of Operation

Quad-Ring® Seals are self energizing double-acting sealing elements. The forces acting in radial or axial direction due to the installation give Quad-Ring® Seal its initial leak-tightness (initial squeeze). These forces are superimposed by the system pressure.

An overall sealing force is created which increases with increasing system pressure (Figure 2). Under pressure, the seal behaves in a similar way to a fluid with high viscosity and the pressure is transmitted uniformly to all sides.

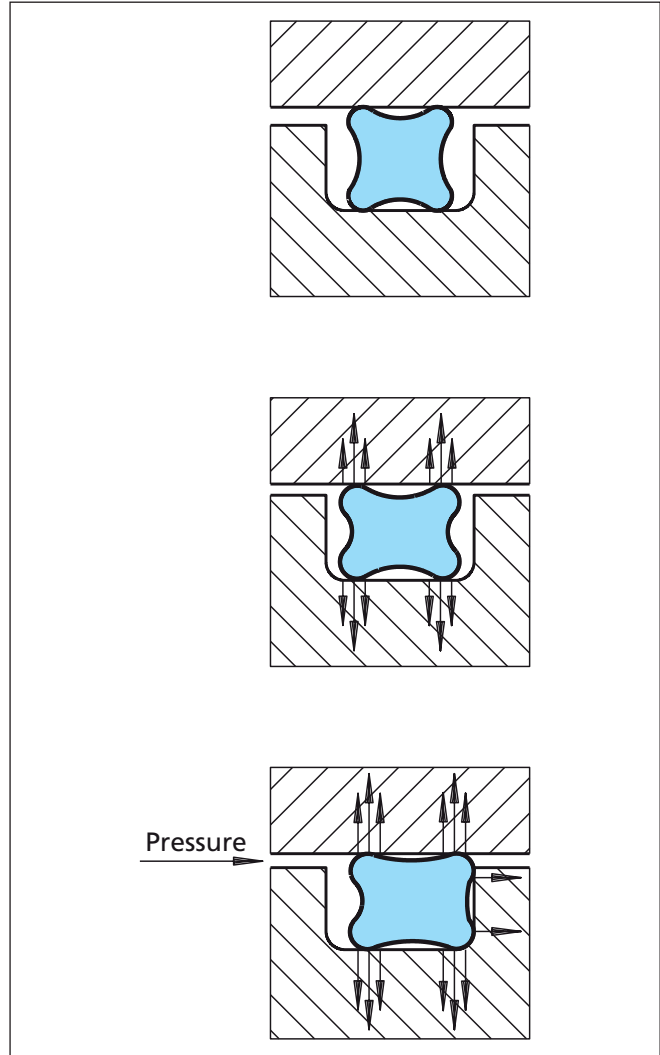

Figure 2 Quad-Ring® Seal squeeze with and without system pressure



## ■ Applications

### Fields of Application

Quad-Ring® Seals can be used for a wide range of different applications.

Quad-Ring® Seal is used predominantly for dynamic sealing functions. Its use is always limited by the pressure to be sealed and the velocity.

#### Dynamic applications

- For sealing of reciprocating pistons, rods, plungers, etc.
- For sealing oscillating, rotating or spiral movements on shafts, spindles, rotary transmission leadthroughs, etc.

#### Static applications

- As a radial-static seal, e.g. for bushings, covers, pipes, etc.
- As an axial-static seal, e.g. for flanges, plates, caps, etc.
- As an energizer element for elastomer energized hydraulic seals where there is a risk of the O-Ring twisting.

### Quad-Ring® Seal for rotary application

In applications with small cyclic periods of activity, Quad-Ring® Seal can also be used for sealing rotating shafts. The following points according to the rotary seal principle should be observed:

The rotary seal principle is based on the fact that an elongated elastomer ring contracts when heated (Joule effect). With the normal design criteria the seal ring inside diameter  $d_1$  will be slightly smaller than the shaft diameter, and the heat generated by friction would cause the ring to contract even more. This results in a higher pressure on the rotating shaft so that a lubricating film is prevented from forming under the seal and even higher friction occurs. The result would be increased wear and a premature failure of the seal.

Using the rotary seal principle, this is prevented by the seal ring being selected so that its inside diameter is approximately 2 to 5% larger than the shaft diameter to be sealed. The installation in the groove means that the seal ring is compressed radially and is pressed against the shaft by the groove diameter. The seal ring is thus slightly corrugated in the groove, a fact which helps to improve the lubrication.

The rotary seal principle can be neglected at peripheral speeds of less than 0.5 m/s.

When using the Quad-Ring® Seal as a rotary seal, the use of a suitable surface coating is recommended. Please note the information given in our brochure "Friction-free Running" or contact your local Trelleborg Sealing Solutions company for further details.

### Technical Data

Quad-Ring® Seals can be used for a wide range of applications. The choice of a suitable material is determined by the temperature, pressure and media. In order to assess the suitability of Quad-Ring® Seal as a sealing element for a given application, the interaction of all the operating parameters have to be taken into consideration.

Working pressure, dynamic application:

#### Reciprocating

up to 5 MPa (50 bar) without Back-up Ring  
up to 30 MPa (300 bar) with Back-up Ring

#### Rotating

up to 15 MPa (150 bar) with Back-up Ring

Working pressure, static application:

up to 5 MPa (50 bar) without Back-up Ring  
up to 40 MPa (400 bar) with Back-up Ring

Please note the permissible extrusion gaps, see Table IV.

Speed:

Reciprocating:		up to 0.5 m/s
Rotating:	briefly	up to 2.0 m/s

Operating temperature range:

depending on material and media resistance, for:

General applications, NBR:	-30 °C to + 100 °C
General applications, FKM:	-18 °C to + 200 °C

When assessing the application criteria, the transient peak and continuous operating temperature and the cyclic duration factor must be taken into consideration. For rotating applications, the increases in temperature due to frictional heat must be taken into account.

Media:

With the large range of materials, each with different properties, which are now available, it is possible to seal against practically all liquids, gases and chemicals. Please note when selecting the most suitable material the information given in the brochure Materials - Chemical Compatibility Guide.



## Materials

The available standard elastomer materials are shown in Table I.

If no particular specifications are given for the material, NBR (Nitrile Butadiene Elastomer) in 70 Shore A will be supplied.

**Table I Standard materials for Quad-Ring® Seals**

Material-Type	NBR Acrylonitrile-Butadien Rubber	FKM Fluorocarbon Rubber
Material code	N7004	V7002
Hardness Shore A (±5)	70	70
Colour	Black	Black
Operating temperature range (°C)	-30 °C to +100 °C	-18 °C to +200 °C
Description	Standard material for hydraulics and pneumatics. Mineral oil-based hydraulic fluids, animal and vegetable oils and fats, aliphatic hydrocarbons, silicone oils and greases, water up to +80°C	Mineral oils and greases, flame retardant liquids, aliphatic, aromatic and chlorinated hydrocarbons, petrol, 99 octane petrol, diesel fuels, silicone oils and greases

Further special materials on request.

Due to the different conditions in the field, e.g. different media, the given material properties and operating temperature ranges could be affected and changed. Tests should be done for each application.

## Characteristics and inspection of elastomers

### Hardness

One of the most often named properties regarding Polymer materials is hardness. Even so the values can be quite misleading.

Hardness is the resistance of a body against penetration of an even harder body - of a standard shape defined pressure.

There are two procedures for hardness tests regarding test samples and finished parts made out of elastomer material:

1. Shore A/D according to ISO 868 / ISO 7619 / DIN 53 505 / ASTM D 2240 Measurement for test samples
2. Durometer IRHD (International Rubber Hardness Degree) according to ISO 48 / ASTM 1414 and 1415 Measurement of test samples and finished parts

The hardness scale has a range of 0 (softest) to 100 (hardest). The measured values depend on the elastic qualities of the elastomers, especially on the tensile strength.

The test should be carried out at temperatures of  $23 \pm 2$  °C not earlier than 16 hours after the last vulcanisation process (manufacturing stage). If other temperatures are being used this should be mentioned in the test report.

Tests should only be carried out with samples which have not been previously stressed mechanically.

### Hardness tests according to Shore A/D

The hardness test device Shore A (indenter with pyramid base) is a sensible application in the hardness range 10 to 90. Samples with a larger hardness should be tested with the device Shore D (indenter with spike). Test specimen: Diameter min. 30 mm Thickness min. 6 mm Upper and lower sides smooth and flat When thin material is being tested it can be layered providing minimal sample thickness is achieved by a maximum of 3 layers. All layers must be at minimum 2 mm thick.

The measurement is done at three different places at a defined distance and time.

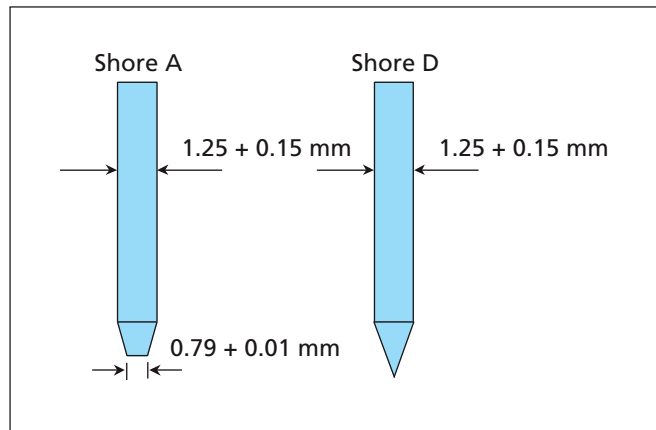

Figure 3 Indenter according to Shore A / D



## Hardness test according to IRHD

The test of the Durometer according to IRHD is used with test samples as well as with finished goods.

The thickness of the test material has to be adjusted according to the range of hardness. According to ISO 48 there are two hardness ranges.

Soft: 10 to 35 IRHD ⇒ Sample thickness  
10 to 15 mm / procedure "L"

Normal: over 35 IRHD ⇒ Sample thickness  
8 to 10 mm / procedure "N"  
Sample thickness  
1.5 to 2.5 mm /  
procedure "M"

The hardness determined with finished parts or samples usually vary in hardness determined from specimen samples, especially those with a curved surface.

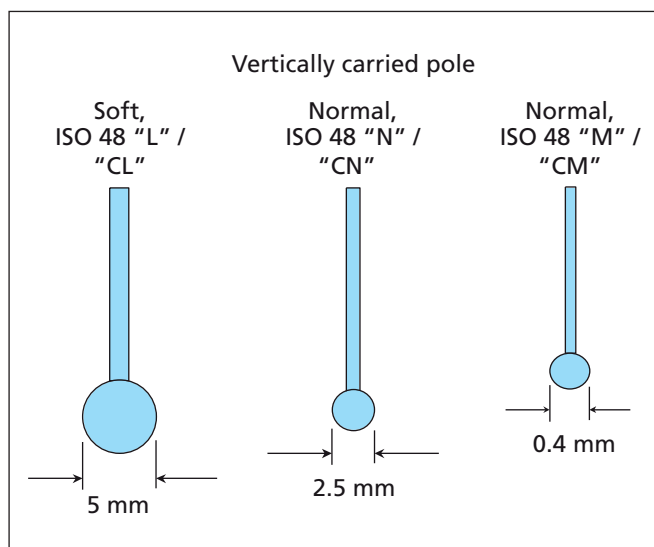

Figure 4 Indentor according to IRHD

## Influencing parameters on the hardness test for polymer materials

Various sample thicknesses and geometries as well as various tests can show different hardness values even though the same materials have been used.

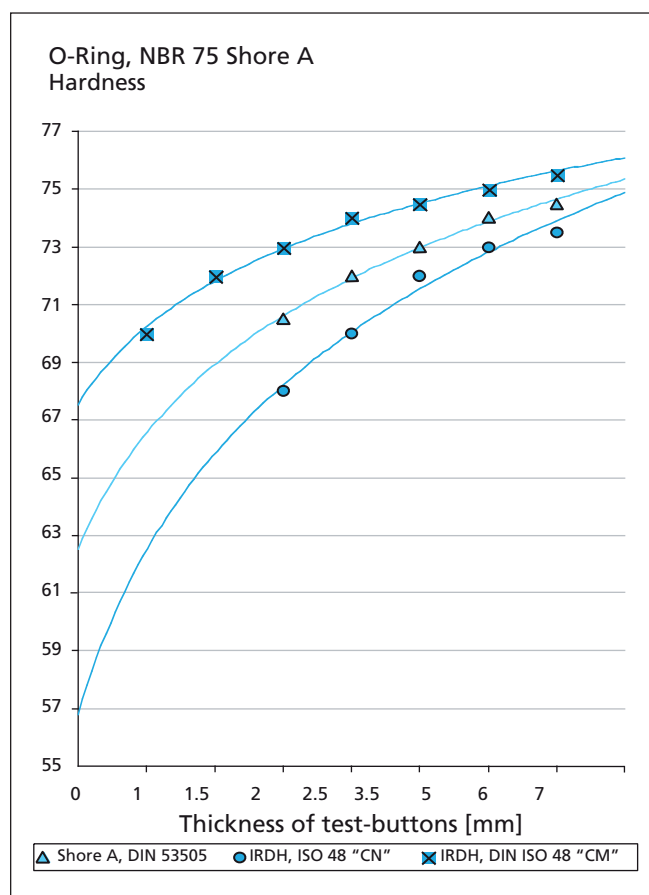

Figure 5 Range of hardness depending on sample thickness and test method

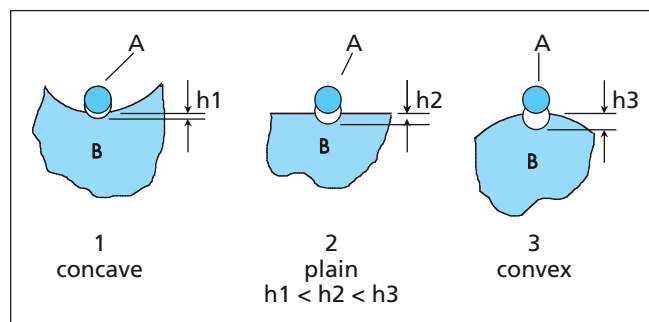

Figure 6 Range of hardness depending on surface geometry for the equivalent material characteristics

With equivalent material characteristics of the elastomer sample B, the indenter penetrates the deepest at the surface 3 (convex) and therefore establishes the softest area.

The measurement of hardness of small Quad-Ring® seals is difficult. The only way that the hardness can accurately be measured is to cut a slice from the Quad-Ring® and measure the hardness of this. However, if this is not possible, the



hardness of the small Quad-Ring® can be measured at the radius or sealing lip as agreed between the customer and Trelleborg Sealing Solutions. This hardness measurement though should only be used to compare the hardness values of different production lots and not to define the real hardness of the individual seal.

## ■ Design Instructions

### Choice of Quad-Ring® Seal size

The chosen cross section  $W$  should be in an appropriate ratio to the inside diameter  $d_1$ . For static applications, Quad-Ring® Seals with smaller cross sections may be used.

### Elongation - Compression

With a radial sealing configuration, Quad-Ring® Seal in an internal groove - "external sealing" - should be stretched over the root of the groove. The maximum elongation in the installed state is 6 % for Quad-Ring® Seals with an inner diameter >50 mm and 8% for Quad-Ring® Seals with an inner diameter <50 mm.

With external grooves - "internal sealing" applications - Quad-Ring® Seal is installed in compressed state. The maximum compression in the installed state is 3 %.

Information regarding elongation and compression are for guidance only.

Exceeding these values will result in an unallowable increase or decrease in Quad-Ring® Seal cross section. Consequently this can affect the service life of the seal. As a rule of thumb: a 1% increase in the inside diameter corresponds to a reduction in the cord diameter of approx. 0.5 %.

### Initial Squeeze

An initial squeeze of Quad-Ring® Seal in the groove is essential to ensure its function as a primary or secondary sealing element (Figure 7). It serves to:

- Achieve the initial sealing capability
- Bridge production-dependent tolerances
- Assure defined frictional forces
- Compensate for compression set
- Compensate for wear.

Depending on the application, the following values apply for the initial squeeze:

### Sealing force with and without system pressure

Dynamic applications:	6 to 18 %
Static applications:	8 to 25 %

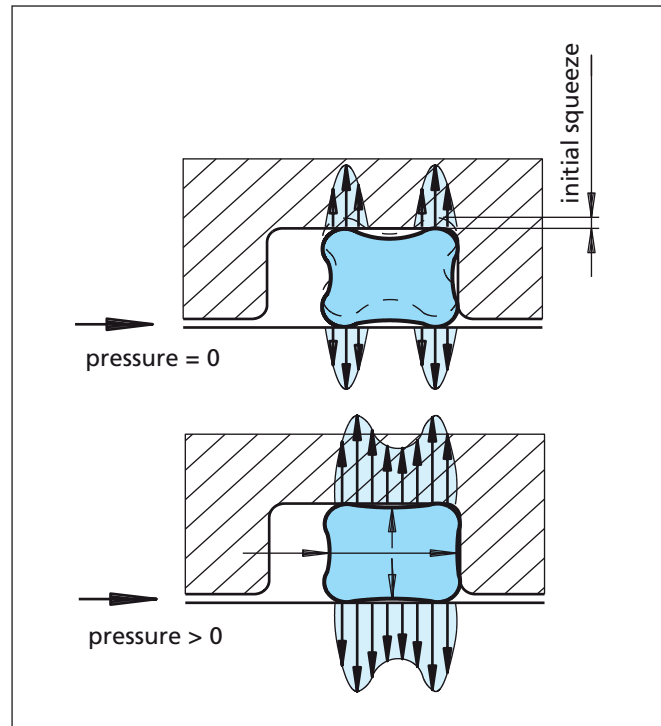

Figure 7 Sealing force with and without system pressure



## Methods of Installation of Quad-Ring® Seals

Quad-Ring® Seals can be used in components in a wide variety of ways.

At the design stage, the subsequent installation situation should be taken into consideration. To avoid damage during installation it is not recommended to assemble the Quad-Ring® Seal over edges or bores. Where long sliding movements are involved, the seal seat should be recessed, if possible, or the sealing elements arranged so they only have to travel short distances during installation.

### Radial Installation (static and dynamic)

Internal sealing

Quad-Ring® Seal size should be selected so that the inside diameter  $d_1$  has the smallest possible deviation from the diameter to be sealed  $d_5$  (Figure 8).

External sealing

Quad-Ring® Seal size should be selected so that the inside diameter  $d_1$  is equal to or smaller than the groove root diameter  $d_3$ .

### Axial-static Installation

During axial-static installation, the direction of the pressure should be taken into consideration when choosing Quad-Ring® Seal size (Figure 9).

With internal pressure, Quad-Ring® Seal outside diameter should be chosen approx. 1 to 2 % larger than the groove outside diameter.

With external pressure, Quad-Ring® Seal is chosen approx. 1 to 3 % smaller than the groove inside diameter.

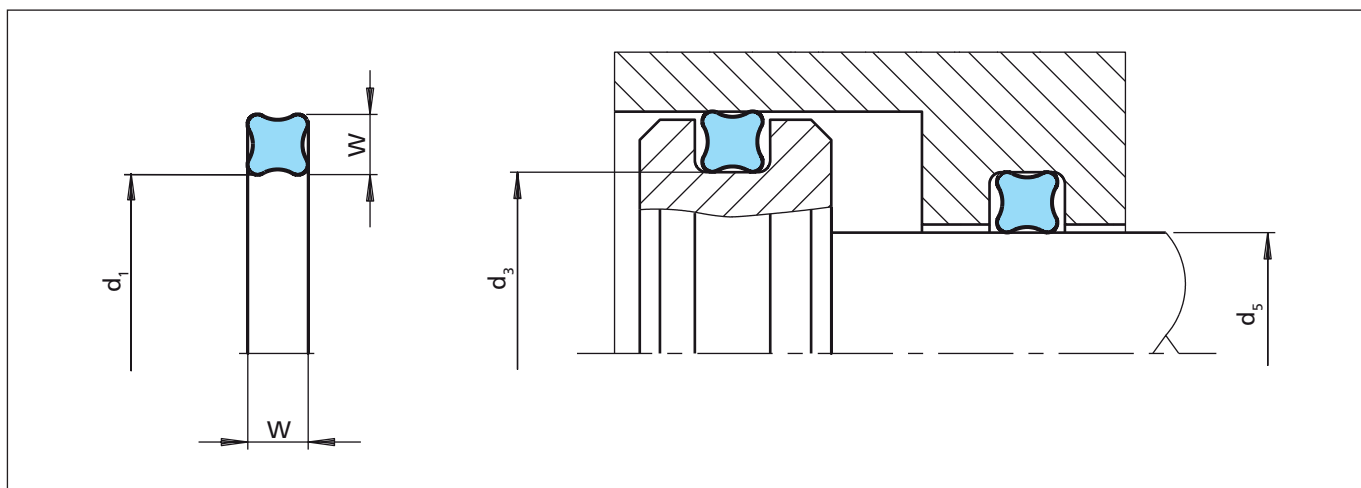

Figure 8 Radial installation, static and dynamic

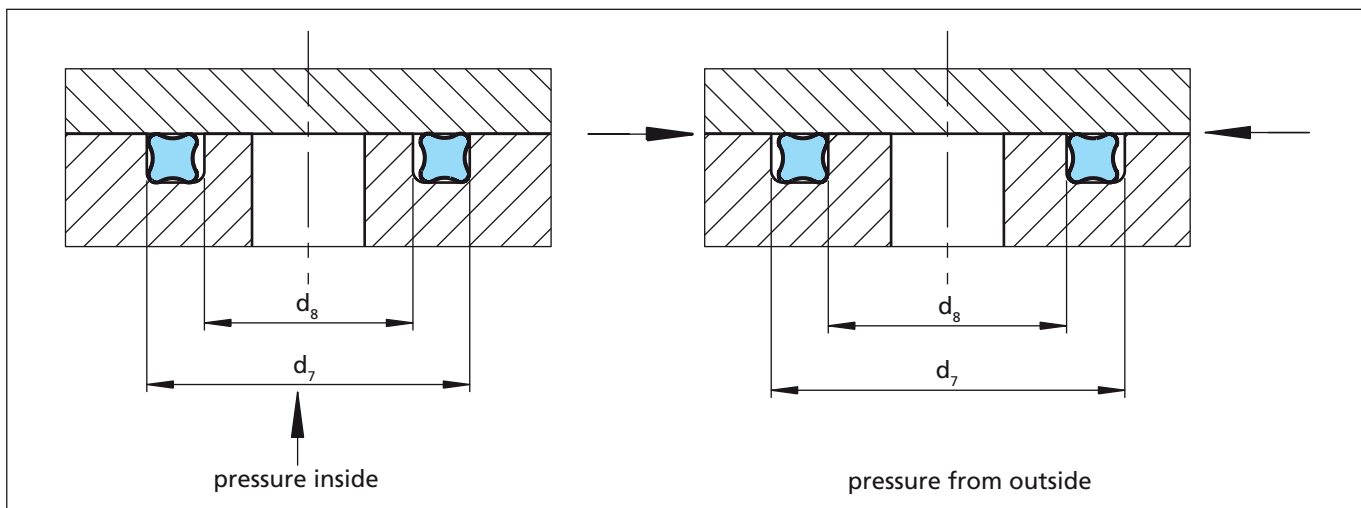

Figure 9 Axial installation, static



## Groove Design

### Rectangular Groove

Quad-Ring® Seals are installed in rectangular grooves. The groove widths specified in our recommendations already take into account a limited swelling of the seals. The maximum permissible gap (Table IV) must be taken into consideration.

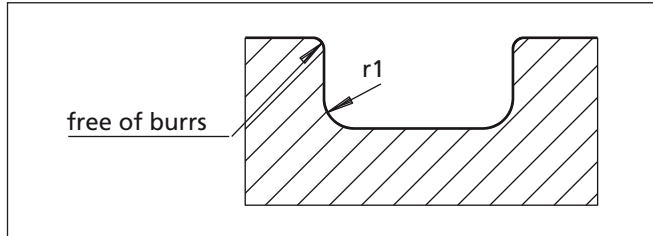

Figure 10 Groove Design

Table II Surface Finish

Type of Load	Surface	$R_t \mu\text{m}$	$R_z \mu\text{m}$	$R_a \mu\text{m}$
Radial-dynamic	Mating surface * (bore, rod, shaft)	$\leq 2.5$	$\leq 1.6$	$\leq 0.4$
	groove flanks, groove diameter	$\leq 10.0$	$\leq 6.3$	$\leq 1.6$
Radial-static Axial-static	Mating surface groove flanks, groove diameter	$\leq 10.0$ $\leq 16.0$	$\leq 6.3$	$\leq 1.6$
	For pulsating pressures Mating surface groove flanks, groove diameter	$\leq 6.3$ $\leq 10.0$	$\leq 6.3$	$\leq 0.8$ $\leq 1.6$

\* spiral free grinding.

The above is for guidance only and covers the majority of sealing applications. However Trelleborg Sealing Solutions should be consulted in areas of particular concern.

## Surfaces

Under pressure, elastomers adapt to irregular surfaces. For gas or liquid-tight joints, however, certain minimum demands must be made on the surface quality of the surfaces to be sealed.

Fundamentally grooves, scratches, pit marks, concentric or spiral machining scores, etc. are not permissible. Higher demands must be placed on the surface quality of dynamic mating surfaces than on static sealing surfaces.

At present, no uniform definitions exist for describing the mating surfaces. In practice, the specification of the  $R_a$  value is not sufficient to permit an assessment of the surface quality. Our recommendations therefore contain amongst others various terms and definitions in accordance with DIN 4768 and DIN EN ISO 4287.



## Lead-in Chamfers

Bearing in mind the subsequent installation requirements during the design of Quad-Ring® Seal can help to eliminate possible sources of damage and seal failure from the outset.

Since Quad-Ring® Seals are always fitted oversize, lead-in chamfers and rounded edges must be provided (Figure 11 and Figure 12).

The lengths of the Lead-in Chamfers are specified in Table III.

The permissible surface roughness of the Lead-in Chamfer is defined as follows:

$$R_z < 6.3 \mu\text{m} \quad R_a < 0.8 \mu\text{m}$$

**Table III Lead-in chamfers**

Lead-in chamfers length Z min.		Quad-Ring® Seal cross section W
15°	20°	
2.5	1.5	up to 1.78 1.80
3.0	2.0	up to 2.62 2.65
3.5	2.5	up to 3.53 3.55
4.5	3.5	up to 5.33 5.30
5.0	4.0	up to 7.00
6.0	4.5	above 7.00

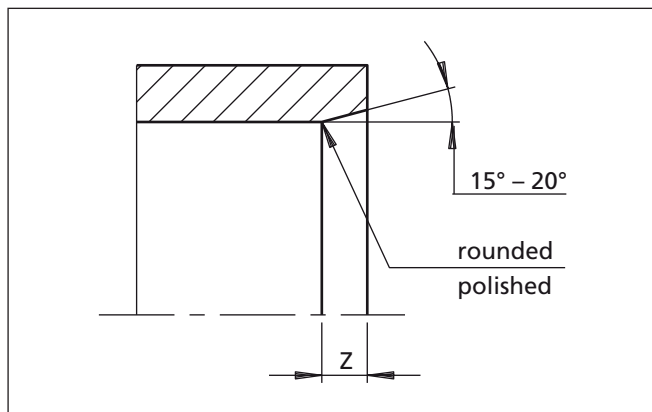

Figure 11 Lead-in chamfer for bores, tubes

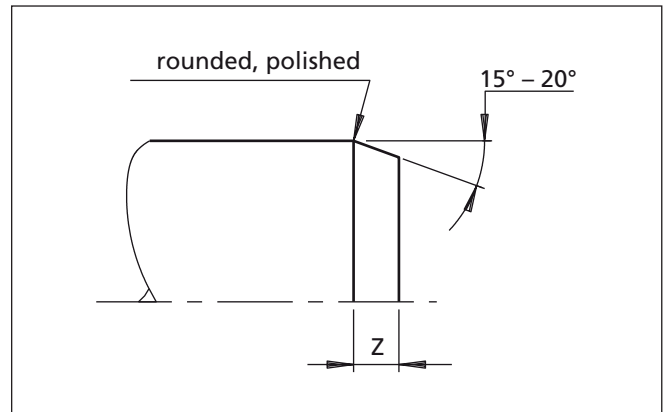

Figure 12 Lead-in chamfer for rods, shafts

## Sealing Gaps

The tolerances and permissible gap dimensions S given in the installation Table IV, must be maintained.

If the extrusion gap is too large, there is a risk of seal extrusion which can result in the destruction of the Quad-Ring® Seal.

The permissible gap S between the parts to be sealed depends on the system pressure, the cross section and the shore hardness of the Quad-Ring® Seal.

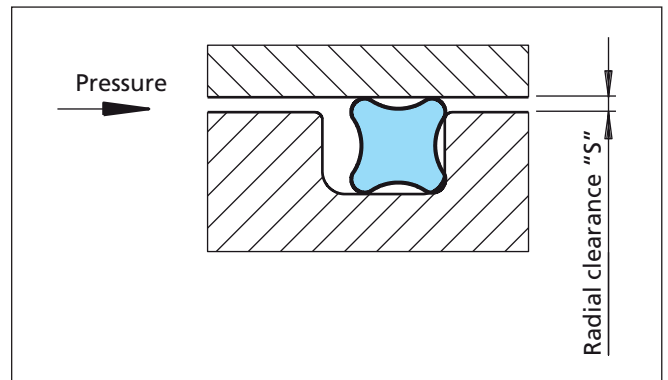

Figure 13 Radial clearance "S"



## Installation of Quad-Ring® Seals with Back-up Rings

Another possible method of protecting Quad-Ring® Seal from extrusion into the gap is the additional installation of Back-up Rings.

The installation of Back-up Rings is generally recommended when at least one of the following conditions exists:

- High pressures - above approx. 5 MPa (50 bar)
- Large tolerances or gaps between the parts to be sealed
- High temperatures or temperature fluctuations during expansion of the parts under pressure
- High degree of contaminants in the system.

Where the pressure acts from only one side, it is sufficient to install a Back-up Ring on the side away from the pressure. Where the pressure acts from both sides, two Back-up Rings - one on each side of Quad-Ring® Seal - are necessary.

A complete summary of our Back-up Ring product range can be found in the catalogue "Static seals".

The following tables show Quad-Ring® - Back-up Ring combinations:

"External" sealing installation, Table VI.

"Internal" sealing installation, Table VII.

Rotary sealing installation, Table VIII.

The selection series contains two Back-up Ring types:

- Split, spiral-type design, preferred for both external and internal sealing applications (bore and shaft)
- One-piece design, preferably for internal sealing applications (shaft) under radially-dynamic loads.

The usage of other Back-up Ring types than given is also possible.

The standard material for the Back-up Ring is virgin PTFE. Special materials, e.g. for injection moulded Back-up Rings, on request.

## ■ Installation Instructions

### General recommendations

Before starting installation, check the following points:

- Lead-in chamfers made according to drawing?
- Bores deburred and edges rounded?
- Machining residues, e.g. chips, dirt and foreign particles, removed?
- Screw thread tips covered?
- Seals and components greased or oiled?  
Ensure media compatibility with the elastomer material. TSS recommends to use the fluid to be sealed.
- Do not use lubricants with solid additives, e.g. molybdenum disulphide or zinc sulphide.

### Manual installation

- Use tools without sharp edges!
- Ensure that the Quad-Ring® Seal is not twisted, use installation aids to assist correct positioning
- Use installation aids wherever possible
- Do not over stretch Quad-Ring® Seals
- Installation over threads, splines etc.

Should the Quad-Ring® Seal have to be stretched over threads, splines, keyways etc., then an assembly mandrel is essential. This mandrel can either be manufactured in a soft metal or a plastic material obviously without burrs or sharp edges.

### Automatic installation

Automatic seal installation requires good preparation. The surfaces of the Quad-Ring® Seals are frequently treated by several methods (see brochure "Friction-free Running"). This offers a number of benefits during installation by

- Reducing the installation forces
- Non-stick effects, easy removal

The handling and installation of dimensionally unstable components requires a great deal of experience. Reliable automated installation thus demands special handling of seals.

Please ask our specialists for further details.



## ■ Installation Recommendations

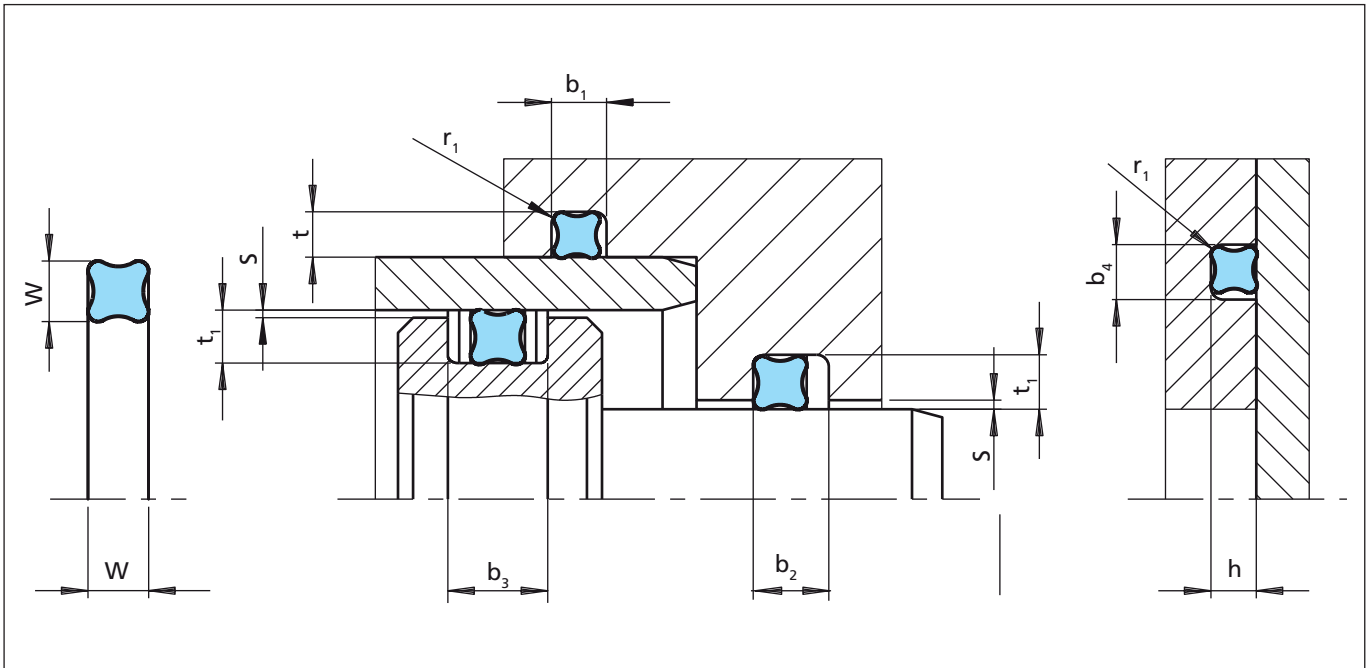

Figure 14 Installation drawing

Table IV Installation Dimensions

Cord Diameter W	Groove Dimensions					Radius <sup>3)</sup> r <sub>1</sub>	Radial Gap S <sub>max.</sub>
	Groove Depth * 1)		Groove Width **				
	Dynamic t <sub>1</sub> + 0.05	Static t/h + 0.05	b <sub>1</sub> , b <sub>4</sub> + 0.2	b <sub>2</sub> + 0.2	b <sub>3</sub> + 0.2		
1.02	0.80	0.75	1.20	2)	2)	0.10	0.03
1.27	1.00	0.90	1.40	2)	2)	0.10	0.03
1.52	1.25	1.15	1.70	2)	2)	0.22	0.04
1.78	1.50	1.40	2.00	2)	2)	0.22	0.05
2.62	2.30	2.25	3.00	2)	2)	0.30	0.08
3.53	3.20	3.10	4.00	2)	2)	0.40	0.08
5.33	4.90	4.75	6.00	2)	2)	0.40	0.10
7.00	6.40	6.20	8.00	2)	2)	0.60	0.10

Explanation for \*, \*\*, see page 12

- 1) Also O-Ring grooves can be generally used. Friction may be higher at dynamic application. Back-up Rings must be adapted.
- 2) When using Back-up Rings the groove is to be increased by the Back-up Ring thickness.
- 3) If a Back-up Ring is used the recommended radius should always be  $r_1 = 0.25 \pm 0.2$  mm.



## General Notes

\* The values quoted for groove depth are average values and apply under medium load conditions in hydraulic applications. For eccentric piston positions or bending of the rod and in vacuum and low-pressure applications, the groove depth should be reduced and/or the initial squeeze increased.

\*\* If a greater swelling of the seal material is anticipated, the groove width can be increased by up to approx. 20%.

The installation dimensions (Table IV, Table VI, Table VII and Table VIII) apply to Quad-Ring® Seals of NBR. Basically all moulds for Quad-Ring® Seal production are laid out for shrinkage behaviour of NBR materials.

Therefore the inside diameter and cross section of Quad-Ring® Seals out of elastomers with a higher shrinkage, such as VMQ or FKM, may differ slightly. FKM Quad-Ring® Seals generally will have slightly smaller dimensions than the corresponding NBR sizes.

Owing to this in particular cases the groove depth must be adapted or rather reduced depending on the application and the nominal sizes of the seal.

As a guide value for the higher shrinkage of FKM materials a difference of approximately 0.5 % may be assumed. Exact values depend on the material and may deviate from this.



## ■ Quad-Ring® Seal dimensions in dependence on the American O-Ring standard AS 568

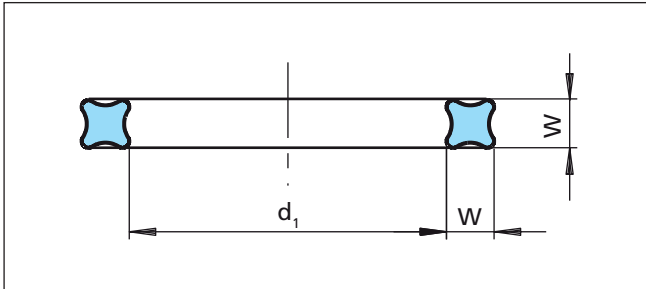

Figure 15 Quad-Ring® Seal

Table V TSS Part Numbers / Dimensions

TSS Part No.	Inside-Ø		Cord Diameter	
	d <sub>1</sub>	±	W	±
QRAR04001	0.74	0.10	1.02	0.08
QRAR04002	1.07	0.10	1.27	0.08
QRAR04003	1.42	0.10	1.52	0.08
QRAR04004	1.78	0.13	1.78	0.08
QRAR04005	2.57	0.13	1.78	0.08
QRAR04006	2.90	0.13	1.78	0.08
QRAR04007	3.68	0.13	1.78	0.08
QRAR04008	4.47	0.13	1.78	0.08
QRAR04009	5.28	0.13	1.78	0.08
QRAR04010	6.07	0.13	1.78	0.08
QRAR04011	7.65	0.13	1.78	0.08
QRAR04012	9.25	0.13	1.78	0.08
QRAR04013	10.82	0.13	1.78	0.08
QRAR04014	12.42	0.13	1.78	0.08
QRAR04015	14.00	0.18	1.78	0.08
QRAR04016	15.60	0.23	1.78	0.08
QRAR04017	17.17	0.23	1.78	0.08
QRAR04018	18.77	0.23	1.78	0.08
QRAR04019	20.35	0.23	1.78	0.08
QRAR04020	21.95	0.23	1.78	0.08
QRAR04021	23.52	0.23	1.78	0.08
QRAR04022	25.12	0.25	1.78	0.08
QRAR04023	26.70	0.25	1.78	0.08
QRAR04024	28.30	0.25	1.78	0.08
QRAR04025	29.87	0.28	1.78	0.08
QRAR04026	31.47	0.28	1.78	0.08
QRAR04027	33.05	0.28	1.78	0.08
QRAR04028	34.65	0.33	1.78	0.08
QRAR04029	37.82	0.33	1.78	0.08
QRAR04030	41.00	0.33	1.78	0.08

TSS Part No.	Inside-Ø		Cord Diameter	
	d <sub>1</sub>	±	W	±
QRAR04031	44.17	0.38	1.78	0.08
QRAR04032	47.35	0.38	1.78	0.08
QRAR04033	50.52	0.46	1.78	0.08
QRAR04034	53.70	0.46	1.78	0.08
QRAR04035	56.87	0.46	1.78	0.08
QRAR04036	60.05	0.46	1.78	0.08
QRAR04037	63.22	0.46	1.78	0.08
QRAR04038	66.40	0.51	1.78	0.08
QRAR04039	69.57	0.51	1.78	0.08
QRAR04040	72.75	0.51	1.78	0.08
QRAR04041	75.92	0.61	1.78	0.08
QRAR04042	82.27	0.61	1.78	0.08
QRAR04043	88.62	0.61	1.78	0.08
QRAR04044	94.97	0.69	1.78	0.08
QRAR04045	101.32	0.69	1.78	0.08
QRAR04046	107.67	0.76	1.78	0.08
QRAR04047	114.02	0.76	1.78	0.08
QRAR04048	120.37	0.76	1.78	0.08
QRAR04049	126.72	0.94	1.78	0.08
QRAR04050	133.07	0.94	1.78	0.08
QRAR04102	1.24	0.10	2.62	0.08
QRAR04103	2.06	0.10	2.62	0.08
QRAR04104	2.84	0.13	2.62	0.08
QRAR04105	3.63	0.13	2.62	0.08
QRAR04106	4.42	0.13	2.62	0.08
QRAR04107	5.23	0.13	2.62	0.08
QRAR04108	6.02	0.13	2.62	0.08
QRAR04109	7.59	0.13	2.62	0.08
QRAR04110	9.19	0.13	2.62	0.08
QRAR04111	10.77	0.13	2.62	0.08
QRAR04112	12.37	0.13	2.62	0.08
QRAR04113	13.94	0.18	2.62	0.08
QRAR04114	15.54	0.23	2.62	0.08
QRAR04115	17.12	0.23	2.62	0.08
QRAR04116	18.72	0.23	2.62	0.08
QRAR04117	20.29	0.25	2.62	0.08
QRAR04118	21.89	0.25	2.62	0.08
QRAR04119	23.47	0.25	2.62	0.08
QRAR04120	25.07	0.25	2.62	0.08
QRAR04121	26.64	0.25	2.62	0.08
QRAR04122	28.24	0.25	2.62	0.08
QRAR04123	29.82	0.30	2.62	0.08



# Quad-Ring® Seal

TSS Part No.	Inside-Ø		Cord Diameter	
	d <sub>1</sub>	±	W	±
QRAR04124	31.42	0.30	2.62	0.08
QRAR04125	32.99	0.30	2.62	0.08
QRAR04126	34.59	0.30	2.62	0.08
QRAR04127	36.17	0.30	2.62	0.08
QRAR04128	37.77	0.30	2.62	0.08
QRAR04129	39.34	0.38	2.62	0.08
QRAR04130	40.94	0.38	2.62	0.08
QRAR04131	42.52	0.38	2.62	0.08
QRAR04132	44.12	0.38	2.62	0.08
QRAR04133	45.69	0.38	2.62	0.08
QRAR04134	47.29	0.38	2.62	0.08
QRAR04135	48.90	0.43	2.62	0.08
QRAR04136	50.47	0.43	2.62	0.08
QRAR04137	52.07	0.43	2.62	0.08
QRAR04138	53.64	0.43	2.62	0.08
QRAR04139	55.25	0.43	2.62	0.08
QRAR04140	56.82	0.43	2.62	0.08
QRAR04141	58.42	0.51	2.62	0.08
QRAR04142	59.99	0.51	2.62	0.08
QRAR04143	61.60	0.51	2.62	0.08
QRAR04144	63.17	0.51	2.62	0.08
QRAR04145	64.77	0.51	2.62	0.08
QRAR04146	66.34	0.51	2.62	0.08
QRAR04147	67.95	0.56	2.62	0.08
QRAR04148	69.52	0.56	2.62	0.08
QRAR04149	71.12	0.56	2.62	0.08
QRAR04150	72.69	0.56	2.62	0.08
QRAR04151	75.87	0.61	2.62	0.08
QRAR04152	82.22	0.61	2.62	0.08
QRAR04153	88.57	0.61	2.62	0.08
QRAR04154	94.92	0.71	2.62	0.08
QRAR04155	101.27	0.71	2.62	0.08
QRAR04156	107.62	0.76	2.62	0.08
QRAR04157	113.97	0.76	2.62	0.08
QRAR04158	120.32	0.76	2.62	0.08
QRAR04159	126.67	0.89	2.62	0.08
QRAR04160	133.02	0.89	2.62	0.08
QRAR04161	139.37	0.89	2.62	0.08
QRAR04162	145.72	0.89	2.62	0.08
QRAR04163	152.07	0.89	2.62	0.08
QRAR04164	158.42	1.02	2.62	0.08
QRAR04165	164.77	1.02	2.62	0.08
QRAR04166	171.12	1.02	2.62	0.08
QRAR04167	177.47	1.02	2.62	0.08
QRAR04168	183.82	1.14	2.62	0.08
QRAR04169	190.17	1.14	2.62	0.08

TSS Part No.	Inside-Ø		Cord Diameter	
	d <sub>1</sub>	±	W	±
QRAR04170	196.52	1.14	2.62	0.08
QRAR04171	202.87	1.14	2.62	0.08
QRAR04172	209.22	1.27	2.62	0.08
QRAR04173	215.57	1.27	2.62	0.08
QRAR04174	221.92	1.27	2.62	0.08
QRAR04175	228.27	1.27	2.62	0.08
QRAR04176	234.62	1.40	2.62	0.08
QRAR04177	240.97	1.40	2.62	0.08
QRAR04178	247.32	1.40	2.62	0.08
QRAR04201	4.34	0.13	3.53	0.10
QRAR04202	5.94	0.13	3.53	0.10
QRAR04203	7.52	0.13	3.53	0.10
QRAR04204	9.12	0.13	3.53	0.10
QRAR04205	10.69	0.13	3.53	0.10
QRAR04206	12.29	0.13	3.53	0.10
QRAR04207	13.87	0.18	3.53	0.10
QRAR04208	15.47	0.23	3.53	0.10
QRAR04209	17.04	0.23	3.53	0.10
QRAR04210	18.64	0.25	3.53	0.10
QRAR04211	20.22	0.25	3.53	0.10
QRAR04212	21.82	0.25	3.53	0.10
QRAR04213	23.39	0.25	3.53	0.10
QRAR04214	24.99	0.25	3.53	0.10
QRAR04215	26.57	0.25	3.53	0.10
QRAR04216	28.17	0.30	3.53	0.10
QRAR04217	29.74	0.30	3.53	0.10
QRAR04218	31.34	0.30	3.53	0.10
QRAR04219	32.92	0.30	3.53	0.10
QRAR04220	34.52	0.30	3.53	0.10
QRAR04221	36.09	0.30	3.53	0.10
QRAR04222	37.69	0.38	3.53	0.10
QRAR04223	40.87	0.38	3.53	0.10
QRAR04224	44.04	0.38	3.53	0.10
QRAR04225	47.22	0.46	3.53	0.10
QRAR04226	50.39	0.46	3.53	0.10
QRAR04227	53.57	0.46	3.53	0.10
QRAR04228	56.74	0.51	3.53	0.10
QRAR04229	59.92	0.51	3.53	0.10
QRAR04230	63.09	0.51	3.53	0.10
QRAR04231	66.27	0.51	3.53	0.10
QRAR04232	69.44	0.61	3.53	0.10
QRAR04233	72.62	0.61	3.53	0.10
QRAR04234	75.79	0.61	3.53	0.10
QRAR04235	78.97	0.61	3.53	0.10
QRAR04236	82.14	0.61	3.53	0.10



TSS Part No.	Inside-Ø		Cord Diameter	
	d <sub>1</sub>	±	W	±
QRAR04237	85.32	0.61	3.53	0.10
QRAR04238	88.49	0.61	3.53	0.10
QRAR04239	91.67	0.71	3.53	0.10
QRAR04240	94.84	0.71	3.53	0.10
QRAR04241	98.02	0.71	3.53	0.10
QRAR04242	101.19	0.71	3.53	0.10
QRAR04243	104.37	0.71	3.53	0.10
QRAR04244	107.54	0.76	3.53	0.10
QRAR04245	110.72	0.76	3.53	0.10
QRAR04246	113.89	0.76	3.53	0.10
QRAR04247	117.07	0.76	3.53	0.10
QRAR04248	120.24	0.76	3.53	0.10
QRAR04249	123.42	0.84	3.53	0.10
QRAR04250	126.59	0.84	3.53	0.10
QRAR04251	129.77	0.84	3.53	0.10
QRAR04252	132.94	0.89	3.53	0.10
QRAR04253	136.12	0.89	3.53	0.10
QRAR04254	139.29	0.89	3.53	0.10
QRAR04255	142.47	0.89	3.53	0.10
QRAR04256	145.64	0.89	3.53	0.10
QRAR04257	148.82	0.89	3.53	0.10
QRAR04258	151.99	0.89	3.53	0.10
QRAR04259	158.34	1.02	3.53	0.10
QRAR04260	164.69	1.02	3.53	0.10
QRAR04261	171.04	1.02	3.53	0.10
QRAR04262	177.39	1.02	3.53	0.10
QRAR04263	183.74	1.14	3.53	0.10
QRAR04264	190.09	1.14	3.53	0.10
QRAR04265	196.44	1.14	3.53	0.10
QRAR04266	202.79	1.14	3.53	0.10
QRAR04267	209.14	1.27	3.53	0.10
QRAR04268	215.49	1.27	3.53	0.10
QRAR04269	221.84	1.27	3.53	0.10
QRAR04270	228.19	1.27	3.53	0.10
QRAR04271	234.54	1.40	3.53	0.10
QRAR04272	240.89	1.40	3.53	0.10
QRAR04273	247.24	1.40	3.53	0.10
QRAR04274	253.59	1.40	3.53	0.10
QRAR04275	266.29	1.40	3.53	0.10
QRAR04276	278.99	1.65	3.53	0.10
QRAR04277	291.69	1.65	3.53	0.10
QRAR04278	304.39	1.65	3.53	0.10
QRAR04279	329.79	1.65	3.53	0.10
QRAR04280	355.19	1.65	3.53	0.10
QRAR04281	380.59	1.65	3.53	0.10
QRAR04282	405.26	1.90	3.53	0.10

TSS Part No.	Inside-Ø		Cord Diameter	
	d <sub>1</sub>	±	W	±
QRAR04283	430.66	2.16	3.53	0.10
QRAR04284	456.06	2.42	3.53	0.10
QRAR04309	10.46	0.13	5.33	0.13
QRAR04310	12.07	0.13	5.33	0.13
QRAR04311	13.64	0.18	5.33	0.13
QRAR04312	15.24	0.23	5.33	0.13
QRAR04313	16.81	0.23	5.33	0.13
QRAR04314	18.42	0.25	5.33	0.13
QRAR04315	19.99	0.25	5.33	0.13
QRAR04316	21.59	0.25	5.33	0.13
QRAR04317	23.16	0.25	5.33	0.13
QRAR04318	24.77	0.25	5.33	0.13
QRAR04319	26.34	0.25	5.33	0.13
QRAR04320	27.94	0.30	5.33	0.13
QRAR04321	29.51	0.30	5.33	0.13
QRAR04322	31.12	0.30	5.33	0.13
QRAR04323	32.69	0.30	5.33	0.13
QRAR04324	34.29	0.30	5.33	0.13
QRAR04325	37.47	0.38	5.33	0.13
QRAR04326	40.64	0.38	5.33	0.13
QRAR04326	40.64	0.38	5.33	0.13
QRAR04327	43.82	0.38	5.33	0.13
QRAR04328	46.99	0.38	5.33	0.13
QRAR04329	50.17	0.46	5.33	0.13
QRAR04329	50.17	0.46	5.33	0.13
QRAR04330	53.34	0.46	5.33	0.13
QRAR04330	53.34	0.46	5.33	0.13
QRAR04331	56.52	0.46	5.33	0.13
QRAR04331	56.52	0.46	5.33	0.13
QRAR04332	59.69	0.46	5.33	0.13
QRAR04333	62.87	0.51	5.33	0.13
QRAR04334	66.04	0.51	5.33	0.13
QRAR04334	66.04	0.51	5.33	0.13
QRAR04335	69.22	0.51	5.33	0.13
QRAR04336	72.39	0.51	5.33	0.13
QRAR04337	75.57	0.61	5.33	0.13
QRAR04338	78.74	0.61	5.33	0.13
QRAR04339	81.92	0.61	5.33	0.13
QRAR04340	85.09	0.61	5.33	0.13
QRAR04341	88.27	0.61	5.33	0.13
QRAR04342	91.44	0.71	5.33	0.13
QRAR04343	94.62	0.71	5.33	0.13
QRAR04344	97.79	0.71	5.33	0.13
QRAR04345	100.97	0.71	5.33	0.13
QRAR04346	104.14	0.71	5.33	0.13



# Quad-Ring® Seal

TSS Part No.	Inside-Ø		Cord Diameter	
	d <sub>1</sub>	±	W	±
QRAR04347	107.32	0.76	5.33	0.13
QRAR04348	110.49	0.76	5.33	0.13
QRAR04349	113.67	0.76	5.33	0.13
QRAR04350	116.84	0.76	5.33	0.13
QRAR04351	120.02	0.76	5.33	0.13
QRAR04352	123.19	0.76	5.33	0.13
QRAR04353	126.37	0.94	5.33	0.13
QRAR04354	129.54	0.94	5.33	0.13
QRAR04355	132.72	0.94	5.33	0.13
QRAR04356	135.89	0.94	5.33	0.13
QRAR04357	139.07	0.94	5.33	0.13
QRAR04358	142.24	0.94	5.33	0.13
QRAR04359	145.42	0.94	5.33	0.13
QRAR04360	148.49	0.94	5.33	0.13
QRAR04361	151.77	0.94	5.33	0.13
QRAR04362	158.12	1.02	5.33	0.13
QRAR04363	164.47	1.02	5.33	0.13
QRAR04364	170.82	1.02	5.33	0.13
QRAR04365	177.17	1.02	5.33	0.13
QRAR04366	183.52	1.14	5.33	0.13
QRAR04367	189.87	1.14	5.33	0.13
QRAR04368	196.22	1.14	5.33	0.13
QRAR04369	202.57	1.14	5.33	0.13
QRAR04370	208.92	1.27	5.33	0.13
QRAR04371	215.27	1.27	5.33	0.13
QRAR04372	221.62	1.27	5.33	0.13
QRAR04373	227.97	1.27	5.33	0.13
QRAR04374	234.32	1.40	5.33	0.13
QRAR04375	240.67	1.40	5.33	0.13
QRAR04376	247.02	1.40	5.33	0.13
QRAR04377	253.37	1.40	5.33	0.13
QRAR04378	266.07	1.52	5.33	0.13
QRAR04379	278.77	1.52	5.33	0.13
QRAR04380	291.47	1.65	5.33	0.13
QRAR04381	304.17	1.65	5.33	0.13
QRAR04382	329.57	1.65	5.33	0.13
QRAR04383	354.97	1.78	5.33	0.13
QRAR04384	380.37	1.78	5.33	0.13
QRAR04385	405.26	1.91	5.33	0.13
QRAR04386	430.66	2.03	5.33	0.13
QRAR04387	456.06	2.15	5.33	0.13
QRAR04388	481.41	2.25	5.33	0.13
QRAR04389	506.81	2.41	5.33	0.13
QRAR04390	532.21	2.41	5.33	0.13
QRAR04391	557.61	2.54	5.33	0.13
QRAR04392	582.68	2.67	5.33	0.13

TSS Part No.	Inside-Ø		Cord Diameter	
	d <sub>1</sub>	±	W	±
QRAR04393	608.08	2.79	5.33	0.13
QRAR04394	633.48	2.92	5.33	0.13
QRAR04395	658.88	3.05	5.33	0.13
QRAR04425	113.67	0.84	6.99	0.15
QRAR04426	116.84	0.84	6.99	0.15
QRAR04427	120.02	0.84	6.99	0.15
QRAR04428	123.19	0.84	6.99	0.15
QRAR04429	126.37	0.94	6.99	0.15
QRAR04430	129.54	0.94	6.99	0.15
QRAR04431	132.72	0.94	6.99	0.15
QRAR04432	135.89	0.94	6.99	0.15
QRAR04433	139.07	0.94	6.99	0.15
QRAR04434	142.24	0.94	6.99	0.15
QRAR04435	145.42	0.94	6.99	0.15
QRAR04436	148.59	0.94	6.99	0.15
QRAR04437	151.77	0.94	6.99	0.15
QRAR04438	158.12	1.02	6.99	0.15
QRAR04439	164.47	1.02	6.99	0.15
QRAR04440	170.82	1.02	6.99	0.15
QRAR04441	177.17	1.02	6.99	0.15
QRAR04442	183.52	1.14	6.99	0.15
QRAR04443	189.87	1.14	6.99	0.15
QRAR04444	196.22	1.14	6.99	0.15
QRAR04445	202.57	1.14	6.99	0.15
QRAR04446	215.27	1.40	6.99	0.15
QRAR04446	215.27	1.40	6.99	0.15
QRAR04447	227.97	1.40	6.99	0.15
QRAR04447	227.97	1.40	6.99	0.15
QRAR04448	240.67	1.40	6.99	0.15
QRAR04449	253.37	1.40	6.99	0.15
QRAR04450	266.07	1.52	6.99	0.15
QRAR04451	278.77	1.52	6.99	0.15
QRAR04452	291.47	1.52	6.99	0.15
QRAR04453	304.17	1.52	6.99	0.15
QRAR04454	316.87	1.52	6.99	0.15
QRAR04455	329.57	1.52	6.99	0.15
QRAR04456	342.27	1.79	6.99	0.15
QRAR04457	354.97	1.79	6.99	0.15
QRAR04457	354.97	1.79	6.99	0.15
QRAR04458	367.67	1.79	6.99	0.15
QRAR04459	380.37	1.79	6.99	0.15
QRAR04460	393.07	1.79	6.99	0.15
QRAR04461	405.26	1.90	6.99	0.15
QRAR04462	417.96	1.90	6.99	0.15
QRAR04463	430.66	2.05	6.99	0.15





## ■ Installation Recommendation Quad-Ring® Seal with Back-up Ring for Radial-Dynamic Application (Reciprocating) - "External Sealing"-

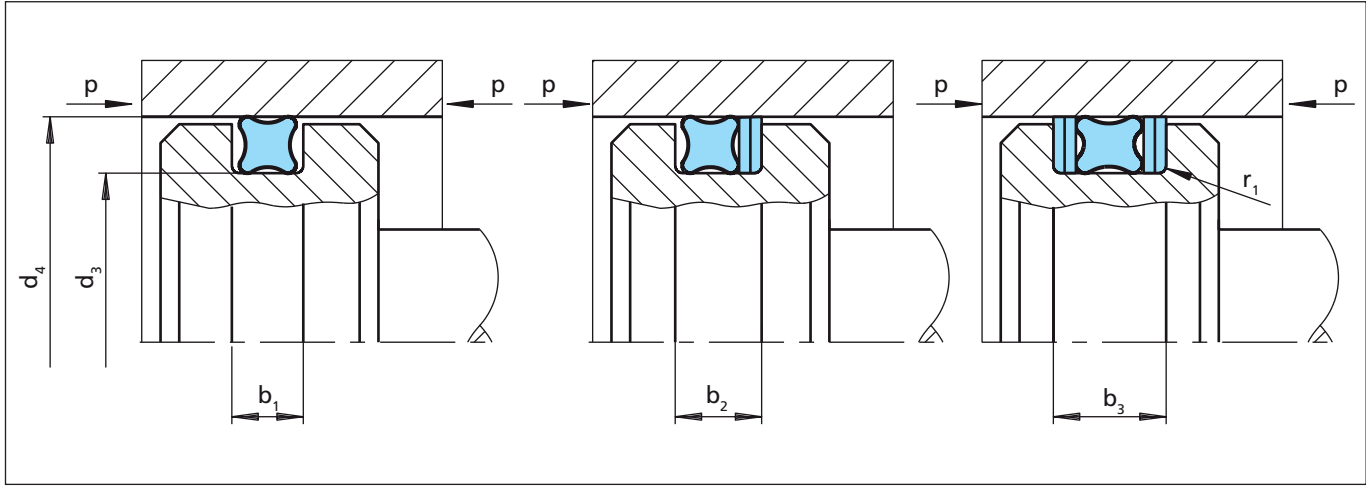

Figure 16 Installation drawing

The following data regarding Back-up Rings and groove widths  $b_2$  and  $b_3$  are exemplary. The use and the suitability of a Back-up Ring type as well as the design of the appropriate groove widths  $b_2$  and  $b_3$  should be verified and adapted regarding the application. For further information please refer to the O-Ring catalogue, chapter "Back-up Rings".

Table VI TSS Part Numbers / Installation Dimensions

Bore	Quad-Ring® Seal		Back-up Ring, Spiral	Groove-Ø	Groove Width			Radius <sup>1)</sup>
	TSS Part No.	dimensions			TSS Part No.	$b_1 + 0.2$	$b_2 + 0.2$	
$d_4$ H8				$d_3$ h9				$r_1$
6.0	QRAR04005	2.57x1.78	BP1500030	3.0	2.0	3.4	4.8	0.2
8.0	QRAR04008	4.47x1.78	BP1500050	5.0	2.0	3.4	4.8	0.2
10.0	QRAR04010	6.07x1.78	BP1500070	7.0	2.0	3.4	4.8	0.2
12.0	QRAR4012A	8.20x1.78	BP1500090	9.0	2.0	3.4	4.8	0.2
14.0	QRAR04013	10.82x1.78	BP1500110	11.0	2.0	3.4	4.8	0.2
15.0	QRAR4111A	10.20x2.62	BP2300104	10.4	3.0	4.4	5.8	0.3
16.0	QRAR04111	10.77x2.62	BP2300114	11.4	3.0	4.4	5.8	0.3
18.0	QRAR04112	12.37x2.62	BP2300134	13.4	3.0	4.4	5.8	0.3
20.0	QRAR4114A	14.70x2.62	BP2300154	15.4	3.0	4.4	5.8	0.3
22.0	QRAR4115A	16.20x2.62	BP2300174	17.4	3.0	4.4	5.8	0.3
25.0	QRAR4210A	18.20x3.53	BP32D0186	18.6	4.0	5.4	6.8	0.4
28.0	QRAR04212	21.82x3.53	BP32D0216	21.6	4.0	5.4	6.8	0.4
30.0	QRAR04213	23.39x3.53	BP32D0236	23.6	4.0	5.4	6.8	0.4
32.0	QRAR04214	24.99x3.53	BP32D0256	25.6	4.0	5.4	6.8	0.4
35.0	QRAR04216	28.17x3.53	BP32D0286	28.6	4.0	5.4	6.8	0.4



Bore	Quad-Ring® Seal		Back-up Ring, Spiral	Groove-Ø	Groove Width			Radius <sup>1)</sup>
	TSS Part No.	dimensions			TSS Part No.	d <sub>3</sub> h <sub>9</sub>	b <sub>1</sub> +0.2	
40.0	QRAR04219	32.92x3.53	BP32D0336	33.6	4.0	5.4	6.8	0.4
42.0	QRAR04220	34.52x3.53	BP32D0356	35.6	4.0	5.4	6.8	0.4
45.0	QRAR04222	37.69x3.53	BP32D0386	38.6	4.0	5.4	6.8	0.4
48.0	QRAR04325	37.46x5.33	BP4900382	38.2	6.0	7.7	9.4	0.4
50.0	QRAR4326A	39.20x5.33	BP4900402	40.2	6.0	7.7	9.4	0.4
52.0	QRAR04326	40.64x5.33	BP4900422	42.2	6.0	7.7	9.4	0.4
55.0	QRAR04327	43.82x5.33	BP4900452	45.2	6.0	7.7	9.4	0.4
60.0	QRAR04329	50.17x5.33	BP4900502	50.2	6.0	7.7	9.4	0.4
63.0	QRAR04330	53.34x5.33	BP4900532	53.2	6.0	7.7	9.4	0.4
65.0	QRAR04330	53.34x5.33	BP4900552	55.2	6.0	7.7	9.4	0.4
70.0	QRAR04332	59.69x5.33	BP4900602	60.2	6.0	7.7	9.4	0.4
75.0	QRAR04333	62.87x5.33	BP4900652	65.2	6.0	7.7	9.4	0.4
80.0	QRAR04335	69.22x5.33	BP4900702	70.2	6.0	7.7	9.4	0.4
85.0	QRAR04337	75.57x5.33	BP4900752	75.2	6.0	7.7	9.4	0.4
90.0	QRAR04338	78.74x5.33	BP4900802	80.2	6.0	7.7	9.4	0.4
95.0	QRAR04340	85.09x5.33	BP4900852	85.2	6.0	7.7	9.4	0.4
100.0	QRAR04342	91.44x5.33	BP4900902	90.2	6.0	7.7	9.4	0.4
105.0	QRAR04343	94.62x5.33	BP4900952	95.2	6.0	7.7	9.4	0.4
110.0	QRAR04345	100.97x5.33	BP4901002	100.2	6.0	7.7	9.4	0.4
115.0	QRAR04346	104.14x5.33	BP4901052	105.2	6.0	7.7	9.4	0.4
120.0	QRAR04348	110.49x5.33	BP4901102	110.2	6.0	7.7	9.4	0.4
125.0	QRAR04349	113.67x5.33	BP4901152	115.2	6.0	7.7	9.4	0.4
130.0	QRAR04351	120.02x5.33	BP4901202	120.2	6.0	7.7	9.4	0.4
135.0	QRAR04427	120.02x6.99	BP64K1222	122.2	8.0	10.5	13.0	0.6
140.0	QRAR04429	126.37x6.99	BP64K1272	127.2	8.0	10.5	13.0	0.6
150.0	QRAR04432	135.89x6.99	BP64K1372	137.2	8.0	10.5	13.0	0.6
160.0	QRAR04435	145.42x6.99	BP64K1472	147.2	8.0	10.5	13.0	0.6
170.0	QRAR04438	158.12x6.99	BP64K1572	157.2	8.0	10.5	13.0	0.6
180.0	QRAR04439	164.47x6.99	BP64K1672	167.2	8.0	10.5	13.0	0.6
190.0	QRAR04441	177.17x6.99	BP64K1772	177.2	8.0	10.5	13.0	0.6
200.0	QRAR04442	183.52x6.99	BP64K1872	187.2	8.0	10.5	13.0	0.6
210.0	QRAR04444	196.22x6.99	BP64K1972	197.2	8.0	10.5	13.0	0.6
220.0	QRAR04445	202.57x6.99	BP64K2072	207.2	8.0	10.5	13.0	0.6
230.0	QRAR04446	215.27x6.99	BP64K2172	217.2	8.0	10.5	13.0	0.6
240.0	QRAR04447	227.97x6.99	BP64K2272	227.2	8.0	10.5	13.0	0.6
250.0	QRAR04447	227.97x6.99	BP64K2372	237.2	8.0	10.5	13.0	0.6



## Quad-Ring® Seal

Bore	Quad-Ring® Seal		Back-up Ring, Spiral	Groove-Ø	Groove Width			Radius <sup>1)</sup>
	TSS Part No.	dimensions			TSS Part No.	d <sub>3</sub> h <sub>9</sub>	b <sub>1</sub> +0.2	
d <sub>4</sub> H8								
280.0	QRAR04450	266.07x6.99	BP64K2672	267.2	8.0	10.5	13.0	0.6
300.0	QRAR04451	278.77x6.99	BP64K2872	287.2	8.0	10.5	13.0	0.6
320.0	QRAR04453	304.17x6.99	BP64K3072	307.2	8.0	10.5	13.0	0.6
350.0	QRAR04455	329.57x6.99	BP64K3372	337.2	8.0	10.5	13.0	0.6
400.0	QRAR04459	380.37x6.99	BP64K3872	387.2	8.0	10.5	13.0	0.6
420.0	QRAR04461	405.26x6.99	BP64K4072	407.2	8.0	10.5	13.0	0.6
450.0	QRAR04463	430.66x6.99	BP64K4372	437.2	8.0	10.5	13.0	0.6
480.0	QRAR04465	456.06x6.99	BP64K4672	467.2	8.0	10.5	13.0	0.6
500.0	QRAR04467	481.46x6.99	BP64K4872	487.2	8.0	10.5	13.0	0.6

1) If a Back-up Ring is used the recommended radius should always be  $r_1 = 0.25 \pm 0.2$  mm.

Further sizes on request!

Materials for QUAD-Ring® Seals, see Table I.



## ■ Installation Recommendation Quad-Ring® Seal with Back-up Ring for Radial-Dynamic Application (Reciprocating) - "Internal Sealing"

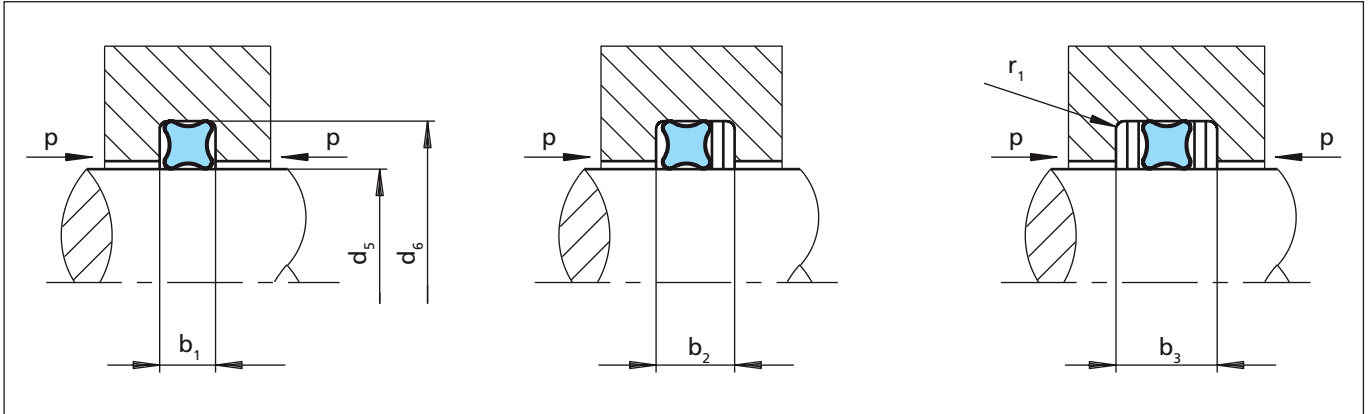

Figure 17 Installation drawing

The following data regarding Back-up Rings and groove widths  $b_2$  and  $b_3$  are exemplary. The use and the suitability of a Back-up Ring type as well as the design of the appropriate groove widths  $b_2$  and  $b_3$  should be verified and adapted regarding the application. For further information please refer to the O-Ring catalogue, chapter "Back-up Rings".

Table VII TSS Part Numbers / Installation Dimensions

Rod	Quad-Ring® Seal		Back-up Ring, Spiral	Groove-Ø	Groove Width			Radius <sup>1)</sup>
	TSS Part No.	dimensions			TSS Part No.	$b_1 + 0.2$	$b_2 + 0.2$	
$d_5$ f7				$d_6$ H9				$r_1$
4.0	QRAR04008	4.47x1.78	BP1500040	7.0	2.0	3.4	4.8	0.2
5.0	QRAR04009	5.28x1.78	BP1500050	8.0	2.0	3.4	4.8	0.2
6.0	QRAR04010	6.07x1.78	BP1500060	9.0	2.0	3.4	4.8	0.2
8.0	QRAR4012A	8.20x1.78	BP1500080	11.0	2.0	3.4	4.8	0.2
10.0	QRAR4111A	10.20x2.62	BP2300100	14.6	3.0	4.4	5.8	0.3
12.0	QRAR04112	12.37x2.62	BP2300120	16.6	3.0	4.4	5.8	0.3
14.0	QRAR04113	13.94x2.62	BP2300140	18.6	3.0	4.4	5.8	0.3
15.0	QRAR4114A	14.70x2.62	BP2300150	19.6	3.0	4.4	5.8	0.3
16.0	QRAR4115A	16.20x2.62	BP2300160	20.6	3.0	4.4	5.8	0.3
18.0	QRAR4210A	18.20x3.53	BP32D0180	24.4	4.0	5.4	6.8	0.4
20.0	QRAR04211	20.22x3.53	BP32D0200	26.4	4.0	5.4	6.8	0.4
22.0	QRAR04212	21.83x3.53	BP32D0220	28.4	4.0	5.4	6.8	0.4
25.0	QRAR04214	24.99x3.53	BP32D0250	31.4	4.0	5.4	6.8	0.4
28.0	QRAR04216	28.17x3.53	BP32D0280	34.4	4.0	5.4	6.8	0.4
30.0	QRAR04217	29.74x3.53	BP32D0300	36.4	4.0	5.4	6.8	0.4
32.0	QRAR04218	31.34x3.53	BP32D0320	38.4	4.0	5.4	6.8	0.4
35.0	QRAR04220	34.52x3.53	BP32D0350	41.4	4.0	5.4	6.8	0.4
36.0	QRAR04221	36.09x3.53	BP32D0360	42.4	4.0	5.4	6.8	0.4



# Quad-Ring® Seal

Rod	Quad-Ring® Seal		Back-up Ring, Spiral	Groove-Ø	Groove Width			Radius <sup>1)</sup>
	TSS Part No.	dimensions			TSS Part No.	d <sub>6</sub> H9	b <sub>1</sub> +0.2	
40.0	QRAR04326	40.64x5.33	BP4900400	49.8	6.0	7.7	9.4	0.4
42.0	QRAR04326	40.64x5.33	BP4900420	51.8	6.0	7.7	9.4	0.4
45.0	QRAR4328A	45.20x5.33	BP4900450	54.8	6.0	7.7	9.4	0.4
48.0	QRAR04328	46.99x5.33	BP4900480	57.8	6.0	7.7	9.4	0.4
50.0	QRAR04329	50.17x5.33	BP4900500	59.8	6.0	7.7	9.4	0.4
52.0	QRAR04329	50.17x5.33	BP4900520	61.8	6.0	7.7	9.4	0.4
55.0	QRAR04330	53.34x5.33	BP4900550	64.8	6.0	7.7	9.4	0.4
56.0	QRAR04331	56.52x5.33	BP4900560	65.8	6.0	7.7	9.4	0.4
60.0	QRAR04332	59.69x5.33	BP4900600	69.8	6.0	7.7	9.4	0.4
63.0	QRAR04333	62.87x5.33	BP4900630	72.8	6.0	7.7	9.4	0.4
65.0	QRAR04334	66.04x5.33	BP4900650	74.8	6.0	7.7	9.4	0.4
70.0	QRAR04335	69.22x5.33	BP4900700	79.8	6.0	7.7	9.4	0.4
75.0	QRAR04337	75.57x5.33	BP4900750	84.8	6.0	7.7	9.4	0.4
80.0	QRAR04338	78.74x5.33	BP4900800	89.8	6.0	7.7	9.4	0.4
85.0	QRAR04340	85.09x5.33	BP4900850	94.8	6.0	7.7	9.4	0.4
90.0	QRAR04342	91.44x5.33	BP4900900	99.8	6.0	7.7	9.4	0.4
100.0	QRAR04345	100.97x5.33	BP4901000	109.8	6.0	7.7	9.4	0.4
105.0	QRAR04346	104.14x5.33	BP4901050	114.8	6.0	7.7	9.4	0.4
110.0	QRAR04348	110.49x5.33	BP4901100	119.8	6.0	7.7	9.4	0.4
115.0	QRAR04426	116.84x6.99	BP64K1150	127.8	8.0	10.5	13.0	0.6
120.0	QRAR04427	120.02x6.99	BP64K1200	132.8	8.0	10.5	13.0	0.6
125.0	QRAR04429	126.37x6.99	BP64K1250	137.8	8.0	10.5	13.0	0.6
130.0	QRAR04430	129.54x6.99	BP64K1300	142.8	8.0	10.5	13.0	0.6
135.0	QRAR04432	135.89x6.99	BP64K1350	147.8	8.0	10.5	13.0	0.6
140.0	QRAR04433	139.07x6.99	BP64K1400	152.8	8.0	10.5	13.0	0.6
150.0	QRAR04436	148.59x6.99	BP64K1500	162.8	8.0	10.5	13.0	0.6
160.0	QRAR4439A	160.50x6.99	BP64K1600	172.8	8.0	10.5	13.0	0.6
170.0	QRAR04440	170.82x6.99	BP64K1700	182.8	8.0	10.5	13.0	0.6
180.0	QRAR04441	177.17x6.99	BP64K1800	192.8	8.0	10.5	13.0	0.6
190.0	QRAR04443	189.87x6.99	BP64K1900	202.8	8.0	10.5	13.0	0.6
200.0	QRAR04445	202.57x6.99	BP64K2000	212.8	8.0	10.5	13.0	0.6
210.0	QRAR04446	215.27x6.99	BP64K2100	222.8	8.0	10.5	13.0	0.6
220.0	QRAR04446	215.27x6.99	BP64K2200	232.8	8.0	10.5	13.0	0.6
230.0	QRAR04447	227.97x6.99	BP64K2300	242.8	8.0	10.5	13.0	0.6
240.0	QRAR04448	240.67x6.99	BP64K2400	252.8	8.0	10.5	13.0	0.6
250.0	QRAR04449	253.37x6.99	BP64K2500	262.8	8.0	10.5	13.0	0.6



Rod	Quad-Ring® Seal		Back-up Ring, Spiral	Groove-Ø	Groove Width			Radius <sup>1)</sup>
	TSS Part No.	dimensions			TSS Part No.	b <sub>1</sub> +0.2	b <sub>2</sub> +0.2	
280.0	QRAR04451	278.77x6.99	BP64K2800	292.8	8.0	10.5	13.0	0.6
300.0	QRAR04453	304.17x6.99	BP64K3000	312.8	8.0	10.5	13.0	0.6
320.0	QRAR04454	316.87x6.99	BP64K3200	332.8	8.0	10.5	13.0	0.6
350.0	QRAR04457	354.97x6.99	BP64K3500	362.8	8.0	10.5	13.0	0.6
360.0	QRAR04457	354.97x6.99	BP64K3600	372.8	8.0	10.5	13.0	0.6
400.0	QRAR04461	405.26x6.99	BP64K4000	412.8	8.0	10.5	13.0	0.6

1) If a Back-up Ring is used the recommended radius should always be  $r_1 = 0.25 \pm 0.2$  mm.

Further sizes on request!

Materials for QUAD-Ring® Seals, see Table I .



## ■ Installation Recommendation Quad-Ring® Seal and Back-up Ring (Uncut) for Rotary Application - "Internal Sealing" -

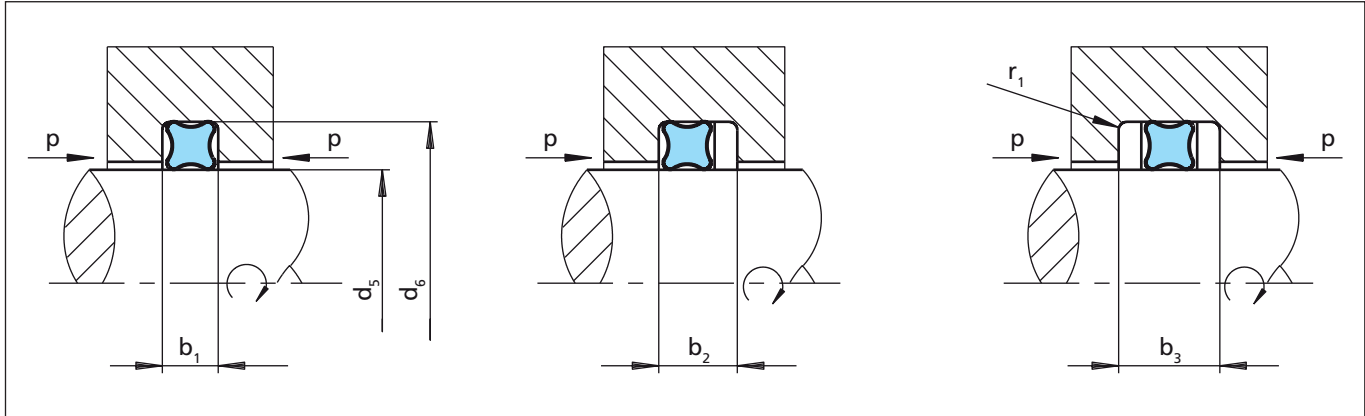

Figure 18 Installation drawing

The following data regarding Back-up Rings and groove widths  $b_2$  and  $b_3$  are exemplary. The use and the suitability of a Back-up Ring type as well as the design of the appropriate groove widths  $b_2$  and  $b_3$  should be verified and adapted regarding the application. For further information please refer to the O-Ring catalogue, chapter "Back-up Rings".

Table VIII TSS Part Numbers / Installation Dimensions

Rod	Quad-Ring® Seal		Back-up Ring, Uncut	Groove-Ø	Groove Width			Radius <sup>1)</sup>
$d_5$ f7	TSS Part No.	dimensions	TSS Part No.	$d_6$ H8	$b_1 + 0.2$	$b_2 + 0.2$	$b_3 + 0.2$	$r_1$
4.0	QRAR04008	4.47x1.78	BU16J0040	7.2	2.0	3.2	4.4	0.2
5.0	QRAR04009	5.28x1.78	BU16J0050	8.2	2.0	3.2	4.4	0.2
8.0	QRAR4012A	8.20x1.78	BU16J0080	11.2	2.0	3.2	4.4	0.2
10.0	QRAR4111A	10.20x2.62	BU24J0100	14.8	2.8	4.0	5.2	0.3
12.0	QRAR04112	12.37x2.62	BU24J0120	16.8	2.8	4.0	5.2	0.3
15.0	QRAR04114	15.54x2.62	BU24J0150	19.8	2.8	4.0	5.2	0.3
16.0	QRAR04115	17.12x2.62	BU24J0160	20.8	2.8	4.0	5.2	0.3
18.0	QRAR04116	18.72x2.62	BU24J0180	22.8	2.8	4.0	5.2	0.3
20.0	QRAR04211	20.22x3.53	BU33N0200	26.7	3.8	5.4	7.0	0.4
22.0	QRAR04213	23.39x3.53	BU33N0220	28.7	3.8	5.4	7.0	0.4
25.0	QRAR04215	26.57x3.53	BU33N0250	31.7	3.8	5.4	7.0	0.4
28.0	QRAR04217	29.74x3.53	BU33N0280	34.7	3.8	5.4	7.0	0.4
30.0	QRAR04218	31.34x3.53	BU33N0300	36.7	3.8	5.4	7.0	0.4
32.0	QRAR04219	32.92x3.53	BU33N0320	38.7	3.8	5.4	7.0	0.4
35.0	QRAR04221	36.09x3.53	BU33N0350	41.7	3.8	5.4	7.0	0.4
36.0	QRAR04222	37.69x3.53	BU33N0360	42.7	3.8	5.4	7.0	0.4
40.0	QRAR04326	40.64x5.33	BU49R0400	49.9	6.0	8.0	10.0	0.4
42.0	QRAR04327	43.82x5.33	BU49R0420	51.9	6.0	8.0	10.0	0.4



Rod	Quad-Ring® Seal		Back-up Ring, Uncut	Groove-Ø	Groove Width			Radius <sup>1)</sup>
	TSS Part No.	dimensions			TSS Part No.	d <sub>6</sub> H8	b <sub>1</sub> +0.2	
45.0	QRAR04328	46.99x5.33	BU49R0450	54.9	6.0	8.0	10.0	0.4
48.0	QRAR04329	50.17x5.33	BU49R0480	57.9	6.0	8.0	10.0	0.4
48.0	QRAR04329	50.17x5.33	BU49R0480	57.9	6.0	8.0	10.0	0.4
50.0	QRAR04330	53.34x5.33	BU49R0500	59.9	6.0	8.0	10.0	0.4
52.0	QRAR04330	53.34x5.33	BU49R0550	61.9	6.0	8.0	10.0	0.4
55.0	QRAR04331	56.52x5.33	BU49R0550	64.9	6.0	8.0	10.0	0.4
56.0	QRAR04331	56.52x5.33	BU49R0560	65.0	6.0	8.0	10.0	0.4
60.0	QRAR04333	62.87x5.33	BU49R0600	69.9	6.0	8.0	10.0	0.4
63.0	QRAR04334	66.04x5.33	BU49R0630	72.9	6.0	8.0	10.0	0.4
65.0	QRAR04334	66.04x5.33	BU49R0650	74.9	6.0	8.0	10.0	0.4
70.0	QRAR04336	72.39x5.33	BU49R0700	79.9	6.0	8.0	10.0	0.4
75.0	QRAR04338	78.74x5.33	BU49R0750	84.9	6.0	8.0	10.0	0.4
80.0	QRAR04339	81.92x5.33	BU49R0800	89.9	6.0	8.0	10.0	0.4
85.0	QRAR04341	88.27x5.33	BU49R0850	94.9	6.0	8.0	10.0	0.4
90.0	QRAR04343	94.62x5.33	BU49R0900	99.9	6.0	8.0	10.0	0.4
95.0	QRAR04344	97.79x5.33	BU49R0950	104.9	6.0	8.0	10.0	0.4
100.0	QRAR04346	104.14x5.33	BU49R1000	109.9	6.0	8.0	10.0	0.4
105.0	QRAR04348	110.49x5.33	BU49R1050	114.9	6.0	8.0	10.0	0.4
110.0	QRAR04426	116.84x6.99	BU66T1100	123.3	7.7	10.2	12.7	0.6
115.0	QRAR04427	120.02x6.99	BU66T1150	128.3	7.7	10.2	12.7	0.6
120.0	QRAR04428	123.19x6.99	BU66T1200	133.3	7.7	10.2	12.7	0.6
125.0	QRAR04430	129.54x6.99	BU66T1250	138.3	7.7	10.2	12.7	0.6
130.0	QRAR04432	135.89x6.99	BU66T1300	143.3	7.7	10.2	12.7	0.6
140.0	QRAR04435	145.42x6.99	BU66T1400	153.3	7.7	10.2	12.7	0.6
150.0	QRAR04438	158.12x6.99	BU66T1500	163.3	7.7	10.2	12.7	0.6
160.0	QRAR04439	164.47x6.99	BU66T1600	173.3	7.7	10.2	12.7	0.6
180.0	QRAR04442	183.52x6.99	BU66T1800	193.3	7.7	10.2	12.7	0.6
200.0	QRAR04445	202.57x6.99	BU66T2000	213.3	7.7	10.2	12.7	0.6

1) If a Back-up Ring is used the recommended radius should always be  $r_1 = 0,25 \pm 0,2$  mm.

Further sizes on request!

Materials for Quad-Ring® Seals, see Table I.

Different procedures for the friction reduction of the elastomer surface are available when using Quad-Ring® in a rotary application. Please refer to our brochure "Friction-free Running" or contact our specialists.



## ■ General Quality criteria

The cost-effective use of seals and bearings is highly influenced by the quality criteria applied in production. Seals and bearings from Trelleborg Sealing Solutions are continuously monitored according to strict quality standards from material acquisition through to delivery.

Certification of our production plants in accordance with international standards QS 9000 / ISO 9000 meets the specific requirements for quality control and management of purchasing, production and marketing functions.

Our quality policy is consistently controlled by strict procedures and guidelines which are implemented within all strategic areas of the company.

All testing of materials and products is performed in accordance with accepted test standards and specifications, e.g. random sample testing in accordance with ISO 2859-1:2004-01 AQL 1,0 general inspection level II, normal inspection.

Inspection specifications correspond to standards applicable to individual product groups.

Our sealing materials are produced free of chloro-fluorinated hydrocarbons and carcinogenic elements. The tenth digit of our part number defines the quality characteristics of the part. A hyphen indicates compliance with standard quality criteria outlined in this catalogue.

Customer-specific requirements are indicated by a different symbol in this position. Customers who require special quality criteria should contact their local Trelleborg Sealing Solutions sales office for assistance. We have experience in meeting all Customer quality requirements.

## ■ Guidelines for the storage of polymer products based on ISO 2230

Many polymer products and components are stored for long periods of time before being put into service, so it is important they are stored in conditions that minimize unwanted changes in properties. Such changes may result from degradation, in which case they may include excessive hardening, softening, cracking, crazing and other surface effects. Other changes may be caused by deformation, contamination or mechanical damage.

### Packaging

Unless otherwise specified in the appropriate product specification, rubber products should be enclosed in individual sealed envelopes. The packaging should be carried out in an atmosphere in which the relative humidity is less than 70%, or if polyurethanes are being packed, less than 65 %. Where there is serious risk of ingress of moisture (e.g. rubber-metal-bonded parts), aluminum foil/paper/polyethylene laminate or other similar means of protection should be used to ensure protection from ingress of moisture.

### Temperature

The storage temperature should be below 25 °C and the products should be stored away from direct sources of heat such as boilers, radiators and direct sunlight. If the storage temperature is below 15 °C, care should be exercised during handling of stored products, as they may have stiffened and have become susceptible to distortion if not handled carefully.

### Humidity

The relative humidity should be such that, given in the variations of temperature in storage, condensation does not occur. In all cases, the relative humidity of the atmosphere in storage should be less than 70%, or if polyurethanes are being stored, less than 65%.

### Light

Rubber should be protected from light sources, in particular direct sunlight or intense light having a high ultra-violet content. It is advisable that any windows of storage rooms be covered with a red or orange coating or screen.

### Radiation

Precautions should be taken to protect stored products from all sources of ionizing radiation likely to cause damage to the products.

### Ozone

Ozone has a particularly harmful effect on rubber. Storage rooms should not contain any equipment that is capable of generating ozone, such as mercury vapor lamps or high-voltage electrical equipment giving rise to electric sparks or electrical discharges. Combustion gases and organic vapors should also be excluded, as they may give rise to ozone via photo-chemical processes. When equipment such as a fork-lift truck is used to handle large rubber products, care needs to be taken to ensure this equipment is not a source of pollution that may affect the rubber. Combustion gases should be considered separately. While they are responsible for generating ground-level ozone, they may also contain unburned fuel which, by condensing on rubber products, can cause additional deterioration.

### Deformation

Rubber should be stored free from tension, compressive stresses or other causes of deformation. Where products are packaged in a strain-free condition, they should be stored in their original packaging. In case of doubt, the manufacturer's advice should be sought. It is advisable that rings of large internal diameter are formed into three equal loops so as to avoid creasing or twisting. It is not possible to achieve this condition by forming just two loops.

### Contact with liquids and semi-liquid materials

Rubber should not be allowed to come into contact with liquid or semi-liquid materials (for example, petrol, greases, acids, disinfectants, cleaning fluids) or their vapors at any time during storage, unless these materials are by design an integral part of the product or the manufacturer's packaging. When rubber products are received coated with their operational media, they should be stored in this condition.



## Contact with metals

Certain metals and their alloys (in particular, copper and manganese) are known to have harmful effects on some rubbers. Rubber should not be stored in contact with such metals except when bonded to them. They should be protected by wrapping in, or by separation with, a suitable material, e.g. paper or polyethylene.

## Contact with dusting powder

Dusting powders should only be used for the packaging of rubber items in order to prevent adhesion. In such cases, the minimum quantity of powder to prevent adhesion should be used. Any powder used should be free from any constituent that would have a harmful effect on the rubber or the subsequent application of the rubber.

## Contact between different products

Contact between products made from rubbers of different compositions should be avoided. This includes products of the same type but differing in color.

## Rubber-to-metal bonded products

The metal part of rubber-to-metal bonded products should not come into contact with the rubber of other products.

Preservative used on the metal should be of a type that it will not adversely affect the rubber or the bond to such an extent that it does not comply with the product specification.

## Storage life

This is the maximum period of time that a rubber product, appropriately packaged, may be stored. After this time the product is regarded as unserviceable for the purposes for which it was originally manufactured. The storage life of a rubber product is influenced by its shape and size as well as its composition. Thick products usually undergo slower changes through degradation than thinner ones.

## Initial storage period

This is the maximum period, starting from the time of manufacture, for which a rubber product, appropriately packaged, may be stored under specified conditions before a sample needs to be inspected or re-tested.

## Extension storage period

This is the period for which a rubber product, appropriately packaged, may be stored after the initial storage period, before further inspection and re-testing is necessary.

**Table IX Initial and extension storage periods for unassembled components**

Material group	Initial storage period	Extension storage period
AU, EU, NR, SBR	5 years	2 years
ACM, AEM, CR, ECO, HNBR, IIR, NBR	7 years	3 years
CSM, EPDM, FKM, FMQ, FVMQ	10 years	5 years
FFKM e.g. Isolast®	20 years	5 years
Zurcon®	10 years	5 years
PTFE	unlimited	

Note 1: If the storage temperature is over or under 25 °C this will influence the storage time. Storage at 10 °C higher will reduce the storage time by about 50%. Storage at 10 °C lower will increase the storage time by around 100 %.

Note 2: In application areas such as aerospace the storage periods can differ from this specification. These specific storage conditions have to be agreed between the supplier and the buyer.

## Assembly

These are products or components containing more than one element, one or more of which is made of rubber. Generally it is not recommended to store elastomeric products in an assembled condition. If it is necessary to do so, the units should be checked more often. The inspection interval depends on the design and geometry of the components.

## Inspection before extension storage

Before any items are to be stored for an extension period, representative samples of each type should be selected for inspection at the end of the appropriate initial storage period. Inspection should be in accordance with the relevant product specification.

## Visual inspection

Inspect each of the items for the following:

1. Permanent distortions, such as creases or flats.
2. Mechanical damage, such as cuts, tears, abraded areas or delaminated plies.
3. Surface cracking when viewed under a microscope at x10 magnification.
4. Changes in surface condition, such as hardening, softening or tackiness.

## Assessment at the end of the initial period

If, following the visual inspection procedure the items are not satisfactory, they should not be stored for an extended period. If the items are satisfactory and are stored for an extended period a record should be kept of the date initial storage began as well as the date the extended storage period began. Items stored for an extended period should be inspected and tested at, or before, the expiry of the extension storage period before they are put into service or stored for a further extended period.



# Conversion Tables

## SI - Basic Units

Measures	Units	Symbol
Length	Metre	m
Mass	Kilogram	kg
Time	Second	s
Electric current	Ampere	A
Temperature	Kelvin	K
Luminous intensity	Candela	cd
Amount of substance	Mol	mol

## Length

	inch	foot	yard	mm	metre
1 inch =		0.0833	0.0278	25.4	0.0254
1 foot =	12		0.333	304.8	0.3048
1 yard =	36	3		914.4	0.9144
1 mm =	0.03937	0.0033	0.00109		0.001
1 metre =	39.37	3.2808	1.0936	1,000	

## Torque

	inch-ounce	inch-pound	foot-pound	kg-metre	Newton-metre
1 inch-ounce =		0.0625	0.0052	$7.2 \times 10^{-4}$	$7.06 \times 10^{-3}$
1 inch-pound =	16		0.0833	$1.152 \times 10^{-2}$	0.1130
1 foot-pound =	192	12		0.1383	1.356
1 kg-metre =	1,388.7	86.796	7.233		9.80665
1 Newton-metre =	141.6	8.850	0.7375	0.1020	

## Area

	inch <sup>2</sup>	foot <sup>2</sup>	yard <sup>2</sup>	mm <sup>2</sup>	m <sup>2</sup>
1 inch <sup>2</sup> =		0.0069	0.00077	645.16	$6.45 \times 10^{-4}$
1 foot <sup>2</sup> =	144		0.111	92,903	0.0929
1 yard <sup>2</sup> =	1,296	9		836,100	0.8361
1 mm <sup>2</sup> =	0.0016	$1.0764 \times 10^{-5}$	$1.196 \times 10^{-6}$		10 <sup>-6</sup>
1 m <sup>2</sup> =	1,550	10.764	1.196	106	

## Pressure

	inch Hg	psi	atmosphere	torr	mm Hg	bar	MPa	kg/cm <sup>2</sup>
1 inch Hg =		0.491	0.0334	25.4	25.4	0.0339	0.00339	0.0345
1 psi =	2.036		0.0680	51.715	51.715	0.0689	0.00689	0.0703
1 atmosphere =	29.921	14.696		760	760	1.0133	0.10133	1.0332
1 torr =	0.0394	0.0193	0.0013		1	0.0013	0.00013	0.00136
1 mm Hg =	0.0394	0.0193	0.0013	1		0.0013	0.00013	0.00136
1 bar =	29.53	14.504	0.987	749.87	749.87		0.1	1.020
1 MPa =	295.3	145.04	9.869	7498.7	7498.7	10		10.2
1 kg/cm <sup>2</sup> =	28.950	14.22	0.968	735.35	735.35	0.980	0.098	

## Volume

	inch <sup>3</sup>	US quart	imp. gallon	foot <sup>3</sup>	US gallon	liter
1 inch <sup>3</sup> =		0.0173	0.0036	0.00058	0.0043	0.0164
1 US quart =	57.75		0.2082	0.0334	0.25	0.9464
1 imp. gallon =	277	4.8		0.1604	1.2	4.546
1 foot <sup>3</sup> =	1,728	29.922	6.23		7.48	28.317
1 US gallon =	231	4	0.8327	0.1337		3.785
1 liter =	61.024	1.0567	0.220	0.0353	0.264	

## Temperature

	°K (Kelvin)	°C	°F
°K =		°C + 273.15	(°F - 459.67) 5/9
°C =	°K - 273.15		(°F - 32) 5/9
°F =	°K 9/5 - 459.67	°C 9/5 + 32	

## Density

	ounce/inch <sup>3</sup>	pound/foot <sup>3</sup>	g/cm <sup>3</sup>
1 ounce/inch <sup>3</sup> =		108	1.73
1 pound/foot <sup>3</sup> =	0.0092		0.016
1 g/cm <sup>3</sup> =	0.578	62.43	

## Force

	Newton (N)	kilopond (kp)	pound force
1 Newton (N) =		0.10197	0.22481
1 kilopond (kp) =	9.80665		2.20463
1 pound force =	4.4482	0.45359	

## Velocity (Speed)

	foot/s	foot/min	mile/hour	metre/s	km/hour
1 foot/s =		60	0.6818	0.3048	1.097
1 ft/min =	0.017		0.0114	0.00508	0.01829
1 mile/hour =	1.4667	88		0.447	1.609
1 metre/s =	3.280	196.848	2.237		3.6
1 km/h =	0.9113	54.68	0.6214	0.278	

## Mass

	ounce	pound	kg
1 ounce =		0.0625	0.0283
1 pound =	16		0.4536
1 kg =	35.274	2.2046	



**Contact your local marketing company for further information:**

<b>Europe</b>	<b>Telephone</b>	<b>Americas</b>	<b>Telephone</b>
<b>AUSTRIA - Vienna</b> (ALBANIA, BOSNIA AND HERZEGOVINA, MACEDONIA, SERBIA AND MONTENEGRO, SLOVENIA)	+43 (0) 1 406 47 33	<b>AMERICAS - REGIONAL</b>	+1 260 749 9631
<b>BELGIUM - Dion-Valmont</b> (LUXEMBOURG)	+32 (0) 10 22 57 50	<b>BRAZIL - São Paulo</b>	+55 11 3372 4500
<b>BULGARIA - Sofia</b> (BELARUS, ROMANIA, TURKEY, UKRAINE)	+359 (0)2 969 95 99	<b>CANADA - Etobicoke, ON</b>	+1 416 213 9444
<b>CROATIA - Zagreb</b>	+385 (0) 1 24 56 387	<b>MEXICO - Mexico City</b>	+52 55 57 19 50 05
<b>CZECH REPUBLIC - Rakovník</b> (SLOVAKIA)	+420 313 529 111	<b>USA, East - Conshohocken, PA</b>	+1 610 828 3209
<b>DENMARK - Copenhagen</b>	+45 48 22 80 80	<b>USA, Great Lakes - Fort Wayne, IN</b>	+1 260 482 4050
<b>FINLAND - Vantaa</b> (ESTONIA, LATVIA)	+358 (0) 207 12 13 50	<b>USA, Midwest - Lombard, IL</b>	+1 630 268 9915
<b>FRANCE - Maisons-Laffitte</b>	+33 (0) 1 30 86 56 00	<b>USA, Mountain - Broomfield, CO</b>	+1 303 469 1357
<b>GERMANY - Stuttgart</b>	+49 (0) 711 7864 0	<b>USA, Northern California - Fresno, CA</b>	+1 559 449 6070
<b>GREECE</b>	+41 (0) 21 631 41 11	<b>USA, Northwest - Portland, OR</b>	+1 503 595 6565
<b>HUNGARY - Budaörs</b>	+36 (06) 23 50 21 21	<b>USA, South - N. Charleston, SC</b>	+1 843 747 7656
<b>ITALY - Livorno</b>	+39 0586 22 6111	<b>USA, Southwest - Houston, TX</b>	+1 713 461 3495
<b>THE NETHERLANDS - Barendrecht</b>	+31 (0) 10 29 22 111	<b>USA, West - Torrance, CA</b>	+1 310 371 1025
<b>NORWAY - Oslo</b>	+47 22 64 60 80		
<b>POLAND - Warsaw</b> (LITHUANIA)	+48 (0) 22 863 30 11	<b>Asia Pacific</b>	<b>Telephone</b>
<b>RUSSIA - Moscow</b>	+7 495 982 39 21	<b>ASIA PACIFIC REGIONAL</b>	+65 6 577 1778
<b>SPAIN - Madrid</b> (PORTUGAL)	+34 (0) 91 71057 30	<b>CHINA - Hong Kong</b>	+852 2366 9165
<b>SWEDEN - Jönköping</b>	+46 (0) 36 34 15 00	<b>CHINA - Shanghai</b>	+86 (0) 21 6145 1830
<b>SWITZERLAND - Crissier</b>	+41 (0) 21 631 41 11	<b>INDIA - Bangalore</b>	+91 (0) 80 2245 5157
<b>UNITED KINGDOM - Solihull</b> (EIRE)	+44 (0) 121 744 1221	<b>JAPAN - Tokyo</b>	+81 (0) 3 5633 8008
<b>AFRICA REGIONAL</b>	+41 (0) 21 631 41 11	<b>KOREA - Seoul</b>	+82 (0) 2 761 3471
<b>MIDDLE EAST REGIONAL</b>	+41 (0) 21 631 41 11	<b>MALAYSIA - Kuala Lumpur</b>	+60 (0) 3 9059 6388
		<b>TAIWAN - Taichung</b>	+886 4 2382 8886
		<b>THAILAND - Bangkok</b>	+66 (0) 2732-2861
		<b>SINGAPORE</b>	
		<b>and all other countries in Asia</b>	+65 6 577 1778

[www.tss.trelleborg.com](http://www.tss.trelleborg.com)